



catalog no. 60



1728 NORTH DAMEN AVE • CHICAGO 47, ILL.

Ludwig—50 years of faithful service to the music world



Wm. F. LUDWIG JR. & SR. *planning new production models in the plant.*

THE LUDWIG DRUM CO. takes pride in presenting this all new Golden Anniversary Catalog No. 60, containing the very latest in modern percussion instruments. Here is the most complete drum, tympani and accessory line ever offered, with the widest selection of sizes and finishes available. The entire Ludwig line is supplied in your choice of either hard "bright" nickel or glistening "triple" chrome plated metal parts.

Ludwig products are built by men with long and successful playing and manufacturing experience. Wm. F. Ludwig Jr. & Sr. are both professional drummers who are alert to the changing requirements and opportunities for improving their instruments.

When you consider Ludwig drums . . . consider the men behind them, men who *know* and *play* drums themselves! This is your guarantee of receiving complete satisfaction!

LUDWIG PERSONNEL



F. K. "PEP" PEPLER,
Sales Manager



CHUCK IVINS,
Asst. Sales Manager



DICK SCHORY,
*Educational &
Advertising Manager*



FRANK ARSENAULT
*Educational
Representative*



CARL GANIER,
Credit Manager



NICK RAVINE,
Eastern Sales



BOB SOUTHEY,
Mid-West Sales



DAVEY DAVIDSON,
Western Sales



SANDY BELFIELD
Mid-West Sales

THE LUDWIG STORY— 50 GOLDEN YEARS OF DRUM PROGRESS

Today the name LUDWIG is without a doubt the MOST FAMOUS NAME ON DRUMS. Fifty golden years of progress and development have established this fact.

FOUNDED IN 1909 by the firms active president, Wm. F. (Bill) Ludwig and his brother Theobald, the Ludwig & Ludwig Co. first operated from a barn on Chicago's west side. Since the Ludwig brothers were both professional drummers, they used their knowledge as performing musicians to develop a line of quality drummers instruments. They manufactured the first upright-post pedal ever built, and introduced the first all-metal separate tension snare drum in America.

From this humble beginning the Ludwig Drum Co. has continued to advance as the world's leading manufacturer of percussion instruments. Many outstanding FIRSTS have been added to the long list of Ludwig achievements: the first pedal tympani made in America; ball bearing drum pedals; double and triple-flanged hoops; chromatic bell

lyra; complete drum outfits; piston bugles with horizontal valve and the throw-off snare release are among the most notable.

Theobald Ludwig passed away in 1918 leaving Wm. F. Ludwig to carry on the business. In the Spring of 1938, Bill Jr., another "drumming Ludwig" joined the firm. With this great father and son team the Ludwig Drum Co. has led the way in the development of percussion instruments.

The Ludwig Co. is continually expanding their facilities to better serve the growing demand for Ludwig products. Today, the Ludwig plant is the world's largest, devoting the entire production to drums and drummers instruments. You are cordially invited to visit the Ludwig Drum Co. any time you are in Chicago. Here you will see master craftsmen of long experience building instruments of the finest quality.

This year Wm. F. Ludwig Sr., and the Ludwig Drum Co. are celebrating two important occasions: 50 years of progress and faithful service to the music world and Mr. Ludwig's 80th birthday. Yes, at 80 years of age, Wm. F. Ludwig along with his son Bill Jr. continue to personally supervise the manufacture of Ludwig products as they have done over the past half century.



The original Ludwig pedal



The Ludwig factory in 1959



The Ludwig factory in 1909

Prices effective June 1, 1959, F.O.B. Factory—Subject to change without notice. Federal excise tax extra.



Ludwig DRUM CO. 1728 No. Damen Ave.
Chicago 47, Illinois
Telephone: ARmitage 6-3301



Introducing . . . **THE NEW
SUPER-LUDWIG ALL-METAL SNARE DRUM**



**HERE, AT LAST, IS THE
ANSWER TO EVERY DRUMMER'S DREAM!**

. . . It's a magnificent drum that speaks with a whisper or a mighty roar. Tone, action, response is well-suited for *every* type or style of drumming from modern progressive jazz to the concert band or orchestra!

The Ludwig all-metal snare drum is *actually treasured* by percussionists because of its versatility . . . its readiness to fit into *every* situation!

There's a proud heritage behind this model . . . one that reaches back thirty years. The old-timers will tell you: "There's nothing like a METAL shell for crispness" and the moderns, like fabulous Joe Morello, echo back "Man, it cuts through like crazy!"

The Super-Ludwig shell construction is one solid piece of brass, beaded in the center and flanged in at the edges for triple strength. Self-aligning lugs are notched to hug the shell. The simplified strainer really works . . . instant throw-off or tension control when you want it! Triple flange hoops provide a solid rim shot every time!

The New Super-Ludwig is for today's

modern drummer who demands the superior instrument . . . perfectly designed for years of trouble-free service.

The new Super-Ludwig is now available in two popular sizes: the 5" x 14" for crisp solo work and the 6½" x 14" for added volume and full resonance.

Both models are supplied with top quality matched plastic heads.

- | | |
|--|------------------|
| No. 400 —5" x 14" All-metal Super-Ludwig, all chrome plated | } \$88.00 |
| No. 401 —5" x 14" All-metal Super-Ludwig, chrome-plated hardware, brass lacquer shell | |
| No. 402 —6½" x 14" All-metal concert model, chrome-plated | } \$90.00 |
| No. 403 —6½" x 14" Chrome hardware, brass lacquered shell | |

Federal Excise Tax Extra

Ludwig

DRUM

THE "Super Classic" MODEL



Advanced, modern design and quality construction has made this model the choice of top professionals from coast to coast. The sturdy laminated shell blends genuine African mahogany with select maple panels and is reinforced with rock-maple glue rings to provide the strongest shell possible. Featuring the new improved Classic throw-off, streamlined self-seating tension casings, the Ludwig *original* triple-flanged counterhoops, and matched heads, the SUPER CLASSIC is truly an instrument of unsurpassed quality in appearance and design.

	<i>Nickel</i>	<i>Chrome</i>
No. 900L — 5½" x 14" Choice of Lacquer Colors.....	\$74.00	\$80.00
No. 900P — 5½" x 14" Choice of Pearl Finishes.....	84.00	90.00

Federal Excise Tax Extra

THE "Symphonic" MODEL

The symphonic artist settles for no less than the best . . . and this model features the best! Traditional Ludwig hand crafted shell . . . sturdy yet light in weight, sixteen self-aligning tension casings, beautiful Classic throw-off, *original* Ludwig triple flanged hoops, and 18 strand coiled wire snares make this the most artistic band and orchestra drum in the world.

All metal parts are highly polished and plated to a glistening lustre for years of lasting beauty. You'll improve your section with a complete set of acoustically correct "Symphonic" model concert drums . . . the drum with the concert sound and the classic appearance.



	<i>Nickel</i>	<i>Chrome</i>
No. 902L — 6½" x 14" Choice of Lacquer Colors.....	\$77.00	\$83.00
No. 902P — 6½" x 14" Choice of Pearl Colors.....	87.00	93.00

Federal Excise Tax Extra



The "JAZZ FESTIVAL" Model

The choice of top jazz artists from coast to coast. Popular 5" shell width provides snappy, crisp response demanded in today's modern arrangements. An effective simplified throw-off offers years of instant trouble-free snare control. Supplied with 8 gleaming self-aligning tension casings, the *original* triple-flanged hoops, and matched THIN heads.

	<i>Nickel</i>	<i>Chrome</i>
No. 908L—5" x 14" Choice of Lacquer Colors.	\$65.00	\$71.00
No. 908P—5" x 14" Choice of Pearl Finishes..	75.00	81.00

Federal Excise Tax Extra

The "PIONEER" Model

Here is the leader in the low priced field, available in two popular sizes: 5" x 14" for dance and solo concert work and the 6½" x 14" for general concert use. The "Pioneer" features Ludwig's sturdy laminated shell reinforced with rock-maple glue rings, six self-aligning tension casings, triple-flanged hoops and the new large "Pioneer" throw-off. Here is true value in a student line instrument. Available in choice of pearl, lacquer or mahogany finishes.

	<i>Nickel</i>	<i>Chrome</i>
No. 491—5" x 14" (M) Mahogany or (L) Lacquer.....	\$49.00	\$54.00
No. 490—6½" x 14" (M) Mahogany or (L) Lacquer.....	51.50	56.50

Pearl finishes, extra..... \$10.00 Gut snares, extra..... \$ 2.00
Wire-gut snares, extra... 3.00 *Federal Excise Tax Extra*



The "SCHOOL FESTIVAL" Model

A quality concert drum designed especially for the school band and orchestra. The "Festival" is acoustically built to provide the correct response and volume for concert hall performance. Specifications: sturdy laminated shell reinforced with rock-maple glue rings, 16 self-aligning tension casings, positive "deep-drop" snare throw-off, *original* triple-flanged hoops, matched heads. Available in your choice of pearl, lacquer or mahogany finishes.

	<i>Nickel</i>	<i>Chrome</i>
No. 912—6½" x 14" (M) Mahogany or (L) Lacquer.....	\$69.00	\$75.00
No. 914—6½" x 15" (M) Mahogany or (L) Lacquer.....	71.00	77.00
No. 916—8" x 15" (M) Mahogany or (L) Lacquer.....	74.00	80.00

Pearl finishes, extra..... \$10.00 Gut snares, extra..... \$2.00
Wire-gut snares, extra... 3.00 *Federal Excise Tax Extra*



The "AUDITORIUM" Model

The new "Auditorium" model is designed to provide the school band and orchestra with a high-quality concert snare drum at a medium-range price. Correctly proportioned for concert use, it comes equipped with 8 self-aligning tension casings, Ludwig's *original* triple-flanged hoops, and the new large "Pioneer" throw-off for instant snare adjustment. Available in choice of pearl, lacquer or mahogany finishes. An outstanding value in the concert field.

	<i>Nickel</i>	<i>Chrome</i>
No. 470—6½" x 14" (M) Mahogany or (L) Lacquer.....	\$61.50	\$67.50
No. 471—6½" x 15" (M) Mahogany or (L) Lacquer.....	65.50	71.50
No. 472—8" x 15" (M) Mahogany or (L) Lacquer.....	69.00	75.00

Pearl finishes, extra..... \$10.00 Gut snares, extra..... \$2.00
Wire-gut snares, extra... 3.00 *Federal Excise Tax Extra*

Ludwig DRUM

Ludwig FAMOUS SNARE DRUMS



The "JAZZ-COMBO" Model

This special separate tension model was designed for small combos and the studio musician. A small head diameter plus narrow shell provides a crisp high-pitched sound made extra sensitive to the touch. The 6 tension casings are self-aligning and placed horizontally on the shell to provide the same head clearance as larger models. The positive action of the "Pioneer" throw-off offers instant snare adjustment.

	Nickel	Chrome
No. 905L—3" x 13" Choice of Lacquer Finishes	\$46.00	\$52.00
No. 905P—3" x 13" Choice of Pearl Finishes..	54.00....	60.00



The "LAS VEGAS" Model

This increasingly popular model combines the higher pitch of the 13" diameter head with the greater volume of a 4" shell. Six self-aligning tension casings are mounted horizontally for proper head clearance. Ludwig's triple-flanged hoops, "Pioneer" strainer and matched heads provide years of trouble-free satisfied service.

	Nickel	Chrome
No. 907L—4" x 13" Choice of Lacquer Colors.	\$54.00	\$60.00
No. 907P—4" x 13" Choice of Pearl Finishes..	59.00....	65.00



The "DOWNBEAT" Model

The "Downbeat" offers all the advantages of the narrow shell plus the added volume and tone of a 14" diameter head. Eight self-aligning tension casings are horizontally mounted for proper head clearance. The original triple-flanged hoops and "Pioneer" throw-off are added quality features. This model is ideal for the traveling artist where space is a problem.

	Nickel	Chrome
No. 906L—4" x 14" Choice of Lacquer Colors.	\$59.00	\$65.00
No. 906P—4" x 14" Choice of Pearl Finishes..	64.00....	70.00



The "SUPER PORTO-PAK" Model

Designed for the drummer desiring a 13" diameter dance drum with the extra volume of a 5" shell. Here is traditional Ludwig quality featuring: 6 full-sized streamlined self-aligning tension casings, triple-flanged hoops, standard deep-drop throw-off and coiled wire snappy snares. Ideal for large combo or small dance band work.

	Nickel	Chrome
No. 480L—5" x 13" Choice of Lacquer Colors.	\$62.00	\$68.00
No. 480P—5" x 13" Choice of Pearl Finishes..	72.00....	78.00

EXCLUSIVE SHELL CONSTRUCTION

Ludwig's hand crafted shells feature the exclusive three ply laminated construction reinforced with solid rock-maple glue rings. Engineered to provide maximum strength and a uniform perfect roundness, LUDWIG shells are the strongest available!



ORIGINAL Triple-Flanged Design

Many attempts have been made to copy the famous Ludwig triple-flanged hoop but none can match the quality and performance of the ORIGINAL. Ludwig hoops are precision engineered for a solid rim shot which eliminates "chewing up" of sticks.



PERFECTION IN SNARE TONE

Snappi-Wire snares are another exclusive feature on all Ludwig snare drums. Each wire is solidly embedded in a plastic snare plate to provide maximum surface contact with drum-head for that sharp, clear, brilliant tone.

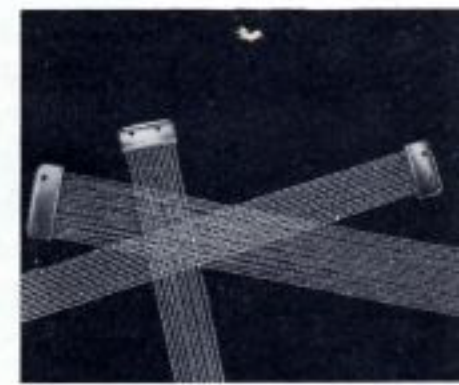

LEARN DRUMMING FAST!.... with your *Ludwig* DRUM KIT



Start Building Your Outfit NOW with
the LUDWIG Drum Kit!

EQUIP YOURSELF WITH THE PROPER INSTRUMENT FOR ALL TYPES OF DRUMMING

The new Ludwig DRUM KIT contains everything for the student drummer in one attractive hard shell, plush-lined case. Compact and easy to carry, this smart looking outfit is ideal for school and home use. The separate tension drum and chrome plated stand provide the proper instrument for concert band and orchestra and at the same time serves as a start for a complete dance outfit. The heavy duty practice pad and extension rod fit on the snare stand base, providing the ideal practice setup.

No. 2442 COMPLETE DRUMMERS KIT as shown \$92.50



COMPLETE DRUM KIT INCLUDES:

No. 491	5" x 14" snare drum in choice of mahogany or multi-color finish	\$ 49.00
	(Supplied in Mahogany unless lacquer color specified)	
No. 1363	Chrome plated "Flat Base" snare stand	9.95
No. 355	All metal practice pad	4.50
No. 355E	Practice pad extension rod	1.00
No. 190	Rubber covered wire brushes	2.00
No. 2B	Drum sticks, pair	1.00
No. 1050	Jazz Drumming Instructor	1.00
No. 1060	Complete Drum Instructor	1.00
No. 1	Rudimental Drum Record	3.00
No. 8025	Hard Shell Plush-Lined Case	24.00
	Total	\$ 96.45
No. 2442	Ludwig Drum Kit as shown	\$92.50

Federal Tax Extra

DE LUXE DRUMMER KIT

The De Luxe Kit contains all of the above items, but is supplied with the No. 900 PC 5½" x 14" Super Classic Snare Drum in choice of pearl finish, chrome plated hardware and luxurious new Super Case with its striking black leather stitched binding for maximum protection and years of eye-catching appeal.

No. 2444—DE LUXE KIT.....\$130.00



**No. 8026 Super Case with
Black Leather Binding \$32.00**

Ludwig DRUM

ECONOMY *Ludwig* DRUM KITS

No. 2445—JUNIOR CONCERT KIT . . . \$60.00

A quality low-priced kit supplied with 5" x 14" concert snare drum in mahogany or choice of multi-color lacquer finish, folding stand and sticks. All items compactly fit into sturdy, lightweight fiber case for protection and easy handling.

Junior Concert Kit consists of:

No. 491	5" x 14" Pioneer snare drum in choice of mahogany or multi-color finish.....	49.00
No. 1357	Snare Stand.....	6.75
No. 2A	Drum Sticks.....	1.00
No. 7152	Special Fibre Case.....	7.50

TOTAL VALUE....\$64.25

No. 2445 Junior Concert Kit.....\$60.00

Excise Tax Extra



No. 2446—JUNIOR MARCHING KIT . \$45.00

An ideal economy marching kit for the beginning drummer. Complete with 10" x 14" sing. ten. parade drum in mahogany or choice of lacquer finish, sticks and sling. Fits neatly into square fibre case for extra protection. Sticks and sling included.

Junior Marching Kit consists of:

No. 3062	10" x 14" parade drum, choice of mahogany or multi-color finish.....	39.50
No. 7153	Fibre Case.....	7.50

TOTAL VALUE....\$47.00

No. 2446 Junior Marching Kit.....\$45.00

Excise Tax Extra

No. 2447—SPOTLIGHT CONCERT KIT . \$75.00

The Spotlight Kit is supplied with 5" x 14" concert snare drum in choice of pearl finish, snare stand—chrome-plated, practice pad, sticks and special fibre case. Everything for the beginning drummer plus the added beauty and protection of pearl.

Spotlight Concert Kit consists of:

No. 491P	5" x 14" Pioneer Snare Drum, choice of pearl finish.....	59.00
No. 1363M	Stand (Modified).....	9.95
No. 354	Practice Pad.....	2.00
No. 2A	Sticks.....	1.00
No. 7152	Special Fibre Case.....	7.50

TOTAL VALUE....\$79.45

No. 2447 Spotlight Concert Kit.....\$75.00

Excise Tax Extra



Ludwig **super . .**

All Ludwig bass drums feature the exclusive non-warping laminated shell, famous for its rugged strength and perfect roundness. Constructed of the finest grade African mahogany and select maple panels reinforced with solid rock-maple glue rings. Ludwig bass drums are built for years of dependable service.

The CLASSIC Model

Here is the top quality line in bass drums featuring large twin "Classic" self-aligning tension casings and matching form-fitting "T" handles. Modern double claw hooks provide even tension over entire head surface. Available in all popular sizes with your choice of pearl or lacquer colors and bright nickel or triple chrome plated hardware. Pearl inlaid hoops included on all models at no extra cost.

	Nickel	Chrome
No. 919L—12" x 20" Choice of Lacquer colors....	\$ 81.00	\$ 91.00
No. 919P—12" x 20" Choice of Pearl finishes.....	111.00	121.00
No. 920L—14" x 20" Choice of Lacquer colors....	84.00	94.00
No. 920P—14" x 20" Choice of Pearl finishes.....	114.00	124.00
No. 921L—12" x 22" Choice of Lacquer colors....	87.00	97.00
No. 921P—12" x 22" Choice of Pearl finishes.....	117.00	127.00
No. 922L—14" x 22" Choice of Lacquer colors....	92.00	102.00
No. 922P—14" x 22" Choice of Pearl finishes.....	122.00	132.00
No. 924L—14" x 24" Choice of Lacquer colors....	102.00	112.00
No. 924P—14" x 24" Choice of Pearl finishes.....	132.00	142.00

Federal Excise Tax Extra

No. 922P—14" x 22"
CLASSIC MODEL

The CENTURY Model Single Tension

The economy of single tension plus the styling of more expensive models add to the value of this popular line. New streamlined center lug provides that modern appearance. Available in your choice of pearl or lacquer finish.

	Nickel	Chrome
No. 3264L—14" x 20" Choice of Lacquer colors.....	\$ 65.00	\$ 77.50
No. 3264P—14" x 20" Choice of Pearl finishes.....	95.00	107.50
No. 3266L—14" x 22" Choice of Lacquer colors.....	76.00	86.00
No. 3266P—14" x 22" Choice of Pearl finishes.....	106.00	116.00
No. 3268L—14" x 24" Choice of Lacquer colors.....	86.00	96.00
No. 3268P—14" x 24" Choice of Pearl finishes.....	116.00	126.00
No. 3272L—14" x 28" Choice of Lacquer colors.....	96.00	106.00
No. 3272P—14" x 28" Choice of Pearl finishes.....	126.00	136.00

(14" x 28" size supplied with eye carrying hooks)

Pearl inlaid hoops on Lacquer models extra—\$3.00

Federal Excise Tax Extra

No. 3272L—14" x 28"
CENTURY SING. TEN. MODEL

Ludwig **DRUM**

BASS DRUMS

The CLASSIC School Model

← Supplied in the popular school sizes with all the exclusive features of the classic line. Equipped with eye carrying hooks for marching use. Equipped with 20 separated large Classic tension casings as illustrated at left.

	Nickel	Chrome
No. 926L—14" x 26" Choice of Lacquer colors...	\$114.00	\$124.00
No. 926P—14" x 26" Choice of Pearl finishes.....	144.00	154.00
No. 928L—14" x 28" Choice of Lacquer colors....	117.00	127.00
No. 928P—14" x 28" Choice of Pearl finishes.....	147.00	157.00

To avoid excessive tension stress on the shell in the larger concert sizes we recommend the SYMPHONIC models on page 10.

The CENTURY Model Separate Tension

→ A superior line of moderately priced *Separate Tension* bass drums featuring the NEW streamlined self-aligning casings. Modern machine turned "T" handles and double claw hooks provide even head tensioning. The center mounted tension casings distribute stress evenly from both sides eliminating excessive stress on the shell. Pearl inlaid hoops included on all models at no extra cost.

	Nickel	Chrome
No. 3244L—14" x 20" Choice of Lacquer colors...	\$ 77.00	\$ 87.00
No. 3244P—14" x 20" Choice of Pearl finishes....	107.00	117.00
No. 3246L—14" x 22" Choice of Lacquer colors...	82.00	92.00
No. 3246P—14" x 22" Choice of Pearl finishes....	112.00	122.00
No. 3248L—14" x 24" Choice of Lacquer colors...	92.00	102.00
No. 3248P—14" x 24" Choice of Pearl finishes....	122.00	132.00
No. 3252L—14" x 28" Choice of Lacquer colors...	102.00	112.00
No. 3252P—14" x 28" Choice of Pearl finishes....	132.00	142.00

Federal Excise Tax Extra



No. 3246L—14" x 22"
CENTURY SEP. TEN. MODEL

The STANDARD Model Single Tension

This fine line of dance and concert model single tension bass drums combine economy and years of serviceability. Precision tension handles, rods and stud center supports provide easy tensioning. Available in mahogany or lacquer colors only.

	Nickel	Chrome
No. 829L—12" x 20" Choice of Lacquer colors..	\$65.00	\$75.00
No. 830L—14" x 20" Choice of Lacquer colors...	73.00	83.00
No. 832L—14" x 22" Choice of Lacquer colors..	81.00	91.00
No. 833 —14" x 28" (M) Mahogany or (L) Lacquer.....	90.00	100.00

Pearl inlaid hoops extra—**\$3.00**

Federal Excise Tax Extra

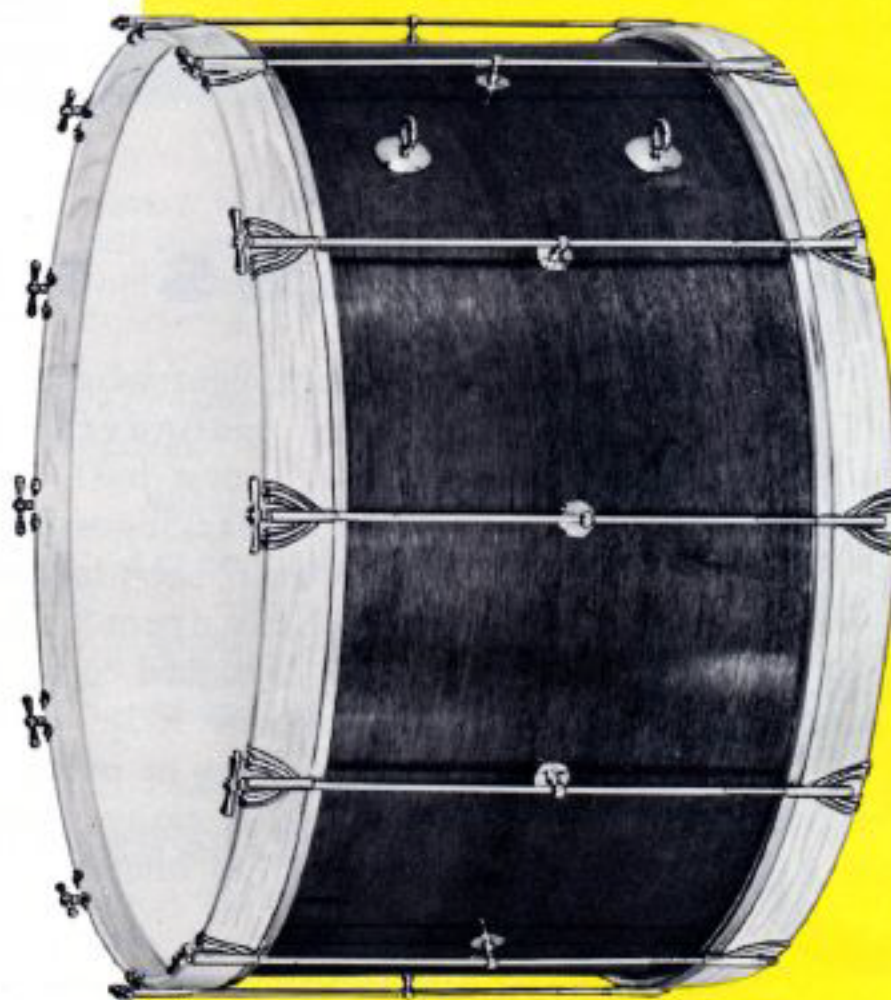

No. 833M—14" x 28"
STANDARD MODEL





CONCERT BASS DRUMS

The famous LUDWIG line of concert bass drums have long been the choice of leading musical organizations the world over. Acoustically designed shells are solidly reinforced with sturdy rock-maple glue rings to maintain perfect roundness and to eliminate tone distortion. The beautifully styled self-aligning tension casings are precision engineered to evenly distribute head tension within itself, thus eliminating excessive stress on the shell.

SPECIFICATIONS:

Ludwig "SYMPHONIC STYLE" concert bass drums are built to professional standards and are available in a wide range of sizes. The popular 16" x 36" size is recommended for most concert work. All models available in choice of pearl, lacquer or mahogany finish with either hard "bright" nickel or glistening "triple" chrome plated hardware.

	<i>Nickel</i>	<i>Chrome</i>
No. 801L—14" x 28" Mahogany or Lacquer finish.	\$117.50	\$127.50
No. 801P—14" x 28" Choice of Pearl finishes . . .	147.50	157.50
No. 802L—14" x 30" Mahogany or Lacquer finish.	127.50	137.50
No. 802P—14" x 30" Choice of Pearl finishes . . .	157.50	167.50
No. 804L—16" x 32" Mahogany or Lacquer finish.	143.00	153.00
No. 804P—16" x 32" Choice of Pearl finishes . . .	173.00	183.00
No. 805L—16" x 34" Mahogany or Lacquer finish.	153.00	163.00
No. 805P—16" x 34" Choice of Pearl finishes . . .	183.00	193.00
No. 806L—16" x 36" Mahogany or Lacquer finish.	168.50	178.50
No. 806P—16" x 36" Choice of Pearl finishes . . .	198.50	208.50
No. 808L—18" x 40" Mahogany or Lacquer finish.	200.00	210.00
No. 808P—18" x 40" Choice of Pearl finishes . . .	230.00	240.00

Pearl inlaid counter hoops are standard on all pearl models. Available at \$3.00 extra on mahogany or lacquer drums. Special sizes upon request. *Federal Excise Tax Extra.*



No. 790—Chrome plated bass drum stand. \$18.00



BASS DRUM CARRIAGE

Compact, light weight and highly maneuverable, Ludwig's new bass drum carriage makes it possible to obtain the concert tone of a large bass drum on the march. Designed to fit any size from 14" x 28" on up. Carriage may be pulled for player or is easily pushed by the player himself.

When ordering, please give size and make of bass drum so that felt padded block will accommodate drum rods.

No. 791—Bass drum carriage. \$100.00



Wheels may be quickly detached for packing. Wood cradle may be used without wheels in concert.

Super Classic TOM TOMS

Super Classic tom toms are fashioned with the same care and attention to detail as all other Ludwig instruments. The sturdy but lightweight laminated shells are a blend of select African mahogany and poplar core, reinforced with rings of solid rock maple.

Ludwig's original triple-flanged hoops and twin "Classic" tension casings are standard on all sizes. Specify your choice of pearl or lacquer finish when ordering. Available with "bright" nickel or triple chrome-plated hardware.

All floor model tom toms are supplied with legs mounted as standard equipment at no additional cost.



No. 950P—16" x 16"
Legs Included



No. 944P—9" x 13"

	Nickel	Chrome
No. 942L—8" x 12" Choice of Lacquer finish.....	\$ 55.00	\$ 60.00
No. 942P—8" x 12" Choice of Pearl finish.....	62.50	67.50
No. 944L—9" x 13" Choice of Lacquer finish	57.00	62.00
No. 944P—9" x 13" Choice of Pearl finish	64.50	69.50

Holders mounted on above models—extra. Specify your choice when ordering.

No. 948L—14" x 14" Choice of Lacquer, legs mounted.....	67.00	74.00
No. 948P—14" x 14" Choice of Pearl, legs mounted	82.00	89.00
No. 950L—16" x 16" Choice of Lacquer, legs mounted	74.50	81.50
No. 950P—16" x 16" Choice of Pearl, legs mounted.....	89.50	96.50
No. 952L—16" x 18" Choice of Lacquer, legs mounted.....	90.00	97.00
No. 952P—16" x 18" Choice of Pearl, legs mounted.....	105.00	112.00
No. 954L—18" x 20" Choice of Lacquer, legs mounted.....	103.00	110.00
No. 954P—18" x 20" Choice of Pearl, legs mounted	118.00	125.00

Club Date TOM TOMS

A quality low price line of separate tension tom toms featuring center row self-aligning tension casings, triple flanged hoops and matched heads. Designed for use with the "Combo" and "Spotlight" outfits. Holders for 9" x 13" size extra at slight additional cost. The 12" x 15" model includes legs mounted as standard equipment.



No. 446L—12" x 15"
Legs Included

	Nickel	Chrome
No. 444L—9" x 13" Choice of Lacquer finishes....	\$47.00	\$52.00
No. 444P—9" x 13" Choice of Pearl finishes.....	54.50	59.50
No. 446L—12" x 15" Lacquer, legs mounted.....	56.00	63.00
No. 446P—12" x 15" Pearl, legs mounted.....	71.00	78.00

TOM TOM HOLDERS & LEGS

All floor tom toms are supplied with legs mounted at no additional cost. Legs may be purchased separately if desired. When ordering smaller sized tom toms indicate your choice of holder for mounting on bass drum. Holders extra. For full details, see page 42.

	Nickel	Chrome
No. 782 —Shell mount holder.	\$12.00	\$14.00
No. 45 —Hoop mount holder	6.00	8.00
No. 5020—Tom Tom Legs.....	7.00	9.00



No. 444L—9" x 13"

NO. 5020 "CLIPPER" TOM TOM LEGS

Quick, effortless adjustment through pressure on a lever locks leg in desired position. Flush-fitting brackets provide easy packing in cases and covers.





Ludwig

LATIN AMERICAN

EXPANDO CONGA DRUMS

Ludwig *Expando* conga drums incorporate a new principle of internal expansion ring tuning. The single screw inside shell raises or lowers pitch in an instant. The playing surface is completely free of any obstructions making hand playing effortless and pleasant. The weight of the laminated tapered shell makes shoulder carrying and transportability easy. Tapered shell provides authentic conga drum resonance. Specifications: Shell depth, 27"; Head diameter, 12".



- No. 2370L—Single Conga Drum, Choice of lacquer finishes.....\$ 55.00
 - No. 2370P—Single Conga Drum, Choice of pearl finishes..... 65.00
 - No. 2375L—Double Conga Drums mounted on stand, Choice of lacquer finishes..... 120.00
 - No. 2375P—Double Conga Drums mounted on stand, Choice of pearl finishes..... 140.00
- Specify colors when ordering.
Federal Excise Tax Extra.



No. 2370P
Single Conga Drum

NEW DESIGN

BONGO Holder & Stand

Ludwig's advance engineering keeps pace with modern player demands by introducing two new accessories: the new bass drum bongo holder and the new floor stand for use with model No. 2358 bongos. Now bongos can be mounted on outfit bass drum in easy playing position for sticks or hands. The new bongo floor stand provides a convenient mounting for use with outfit or in the concert percussion section. Bongos may be taken off stand instantly for between the knees playing.

- No. 46 —Holder only for No. 2358 Bongos. \$ 5.00
- No. 1346—Bongo floor stand with clip attachment for No. 2358 Bongos, chrome only..... 10.00



No. 46
Bass Drum Bongo Holder



No. 1346
Bongo stand and clip

DRUMS OF ULTIMATE PERFECTION



No. 65
Timbales Cover

AUTHENTIC LATIN TIMBALES

Ludwig authentic Latin-style Timbales have the true Latin sound so important for today's popular rhythms. An exclusive design combines flesh hoop and counter hoop into one. Head is mounted on special hoop to eliminate cumbersome double claw hooks and to provide instant key tuning. Shells are beautifully finished in brass or copper, highly buffed and polished to a gleaming luster. Supplied complete with adjustable folding chrome stand for seated or standing playing positions. Sizes: 6½" x 14" and 6½" x 13".

No. 2352—Timbales and stand, copper finish } **\$79.50**
 No. 2354—Timbales and stand, brass finish . } **pair**

Chrome plated hardware on Timbales, extra... **\$4.50**

No. 65—Zipper cover to hold both timbales..... **7.00**

Federal Excise Tax Extra



No. 2358P
Wood Shell Bongos

LUDWIG TUNEABLE BONGOS

Ludwig professional model tuneable bongos are available in two styles . . . wood shell 5½" x 6" and 5½" x 8" with conventional key tuning or metal shell with "Expando" tuning. Sizes: 6" and 8" diameter and 6½" deep. Both models produce the authentic Latin tone and feature a clear playing surface. The "Expando" all-metal model is easily tuned by means of a single internal tension screw as illustrated.

- | | Nickel | Chrome |
|--|---------|---------|
| No. 2358L—Tunable wood shell bongos, choice of lacquer colors..... | \$45.00 | \$52.50 |
| No. 2358P—Tunable wood shell bongos, choice of pearl colors..... | 52.50 | 60.00 |
| No. 2357 —All metal Expando Bongos, white lacquer only..... | 40.00 | |
- Federal Excise Tax Extra*



No. 2357
EXPANDO Bongos

Ludwig DRUM CO.

1728 No. Damen Ave. • Chicago 47, Illinois





Ludwig

**COCKTAIL-LOUNGE
DRUM**

Here is the latest design for the "stand up" performer playing in small lounges. Ideal for the entertaining musician with a small combo or vocal group. Features full height adjustment—sufficient depth for proper resonance—and ample head diameter for either stick or wire brush technique. Specifications: 16" diameter, 24" deep.

- | | | |
|---|----------------|----------------|
| No. 2376L —Cocktail Lounge Drum, | <i>Nickel</i> | <i>Chrome</i> |
| Choice of Lacquer | \$60.00 | \$65.00 |
| No. 2376P —Cocktail Lounge Drum, | | |
| Choice of Pearl | \$85.00 | \$90.00 |

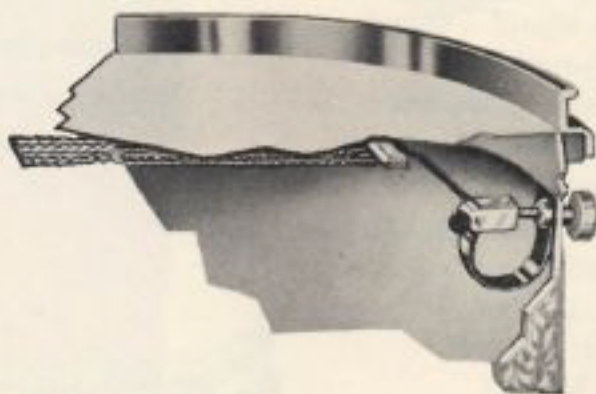

Cut-away drawing shows the unique arrangement of Ludwig originated pressure snares against inside of batter head to provide a simulated snare drum sound. Snare tension is fully adjustable by means of shell-mounted control knob.



MA-RAC-AS

The beauty and tone of Ludwig maracas is incomparable. They are hand turned from only choice wood and finished to a glossy luster. Balanced shot provides the clear high pitch desired. Guaranteed against defects.

- No. 2365**—Ma-rac-as,
per pair . . . **\$5.00**



GUIRO

Ludwig's *Professional Quality* hand carved guiro produces the authentic Latin tone. Evenly spaced deep grooves provide clear tone and resonance. Supplied with quality scraper.

- No. 2367**—Guiro and scraper **\$7.50**



KA-ME-SO

The Kameso is filled with shot and supplies the same tone as maracas except is capable of longer rolls for legato movements. Can be used from end to end or with a gentle rolling motion. Hand painted and polished.

- No. 2369**—Ka-Me-So **\$7.50**

CLAVES



Claves are the basic instruments for playing today's popular Latin rhythms. Here are top quality claves that produce the authentic high pitch that is so important. Hand turned, painted and polished to a gleaming luster—they will not crack or split with ordinary care.

- No. 2368**—Claves, per pair . . . **\$2.50**

THE WORLD'S GREATEST DRUMMERS USE *Ludwig*



JOE MORELLO

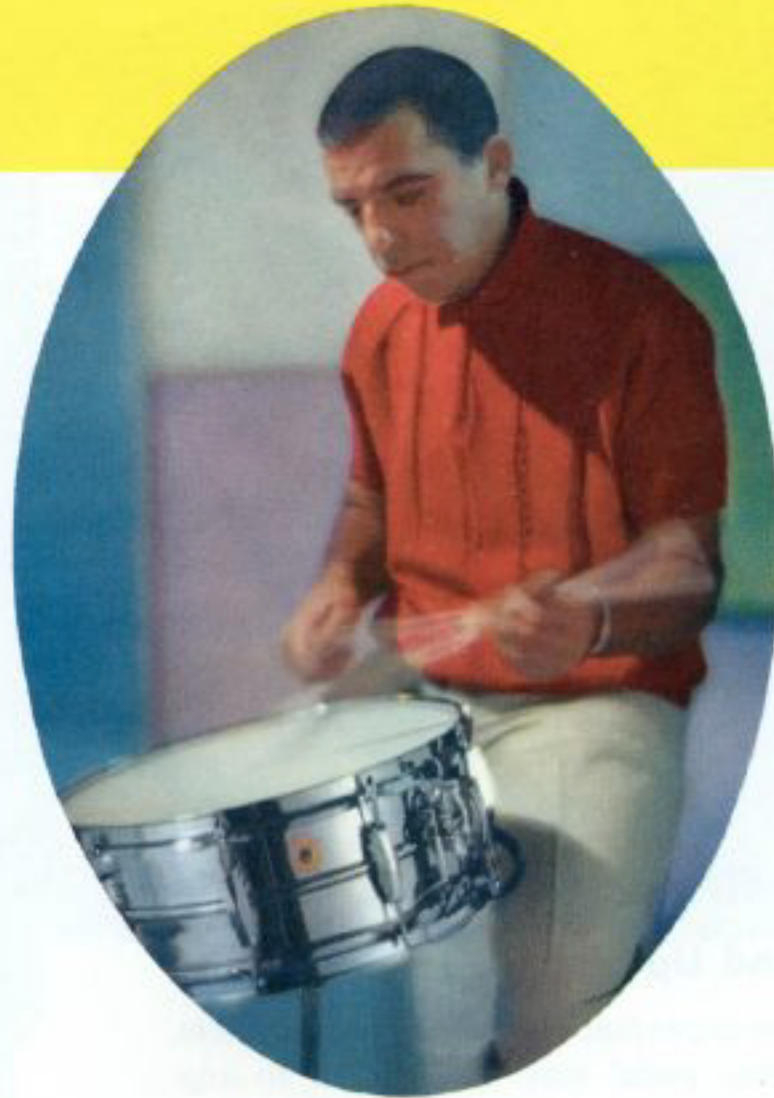

BUDDY RICH



JO JONES



DAVE BLACK



STAN LEVEY



OSIE JOHNSON



CONNIE KAY



JERRY MCKENZIE



RAY MCKINLEY



EDMOND THIGPEN



..... *Most famous Name on Drums!*

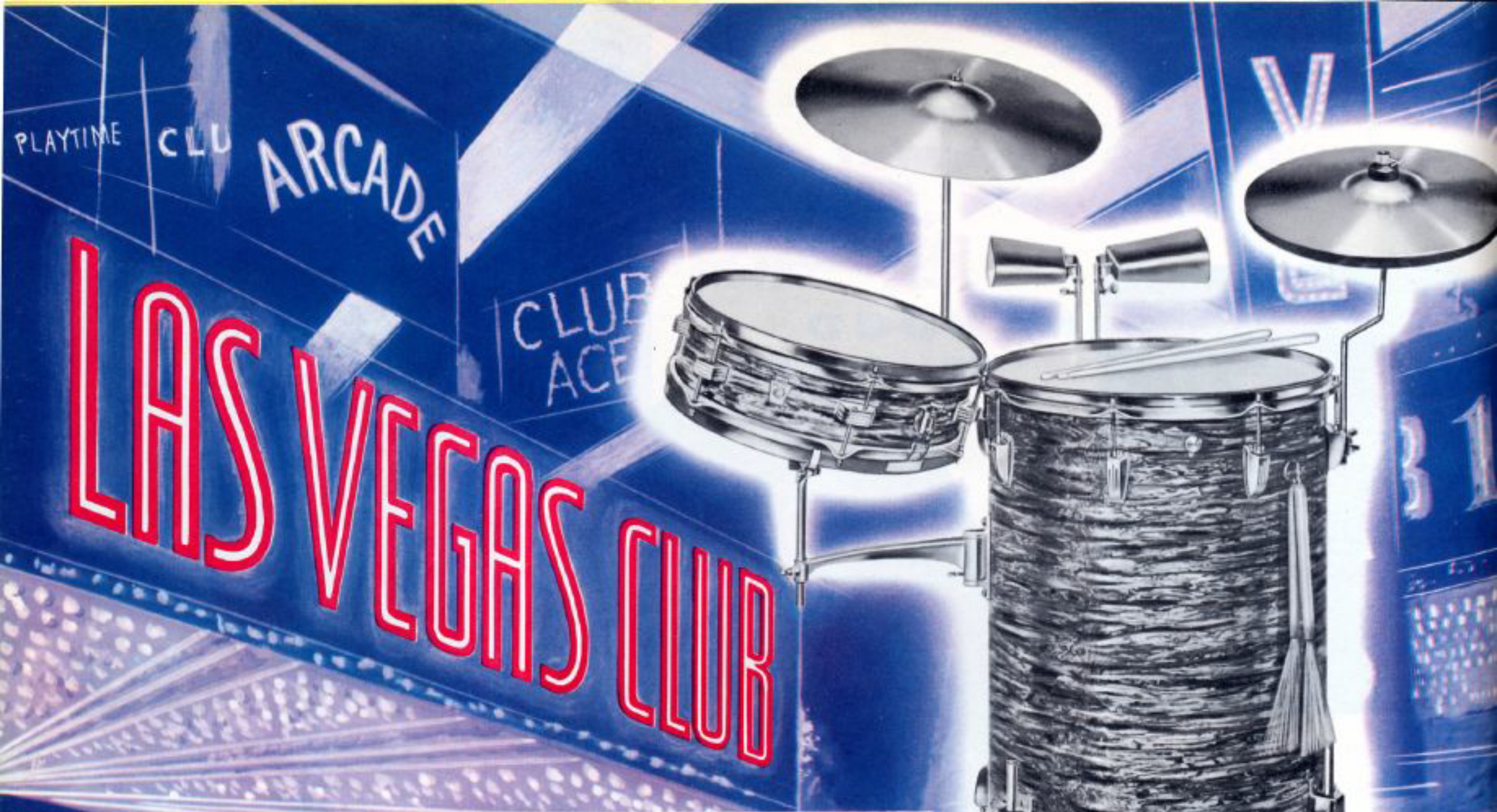

THE LAS VEGAS STAND-UP SET

Here's the most COMPLETE "Stand Up" set we've ever built!

The new "Las Vegas" set contains *all* of the important elements of the complete professional outfit. Shell mounted, up-beat pedal may be adjusted to any stroke. Crisp, narrow snare drum swings from side of bass-tom for all playing positions . . . no stand to get in the way! Shell-mount cymbal holders fully adjustable . . . complete set can be picked up for fast moving!

Special hi-hat clutch holder permits laying two cymbals together face to face in varying degrees of tension to simulate hi hat cymbal tones. By raising top cymbal the cymbals may be made to jangle openly and with great resonance. Lower upper cymbal to close cymbals for those pianissimo tight tones you may desire! Wire brushes hook-on side of shell within action-reach!

Yes, the "Las Vegas" stand-up set provides every playing convenience for general jobbing and master-of-ceremony dates!

No. 1108LC—Las Vegas outfit, lacquer colors, chrome **\$210.00**

No. 1108PC—Las Vegas outfit, pearl colors, chrome **238.00**

Cymbals not included—Excise Tax Extra.



With this complete drum set you can stand up and play. Ideal for entertainers, singers, comedians, and masters-of-ceremonies! Full snare drum and hi hat effects plus "ride" cymbal holder and bass drum beat! (Cymbals NOT included in prices but extra according to selection.)

LAS VEGAS OUTFIT consists of:

	Chrome Hardware	Lacquer	Pearl
No. 907 4" x 13" Snare.....		\$ 60.00	\$ 65.00
No. 2378 24" deep x 16" dia. bass-tom with legs		104.50	129.50
No. 208 Up-beat Pedal.....		18.00	18.00
No. 1374 Hi Hat Cym. attachment		8.00	8.00
No. 1369B Cymbal holder.....		8.00	8.00
No. 128 4" Cow Bell.....		2.00	2.00
No. 129 5" Cow Bell.....		2.25	2.25
No. 127 Double Cow Bell Holder.....		2.00	2.00
No. 1353 Snare Drum Swing Holder, Shell Mtd.....		13.00	13.00
No. 319 Joe Morello Sticks....		1.00	1.00
No. 195 White plastic brushes..		2.00	2.00
		Total Value.. \$220.75	\$250.75

This outfit not supplied in nickel.
Cymbals not included—Excise Tax Extra.

OYSTER BLACK
PEARL AS
ILLUSTRATED

Ludwig



Ludwig

SKY BLUE PEARL AS ILLUSTRATED

... **NEW**

BLUE NOTE OUTFIT

The ultimate in modern outfits for today's progressive drummer who demands the very best. Twin bass drums and tom toms provide nine separate tone changes and thousands of rhythmic combinations. Top quality throughout incorporating all of Ludwig's exclusive features. The twin 8" x 12" tom toms are mounted on new tilting-adjustable floor stand. Bongos slip on and off stand quickly for between-the-knees playing.

- No. 981 P** Blue Note Outfit, Choice of Pearl Finishes, less all cymbals..... **\$842.50**
- No. 981 PC** Blue Note Outfit, Choice of Pearl Finishes, with all hardware chrome plated..... **\$900.00**
Cymbals Not Included—Excise Tax Extra

- 1—No. 908P 5" x 14" Snare Drum, choice of pearl..... **\$ 75.00**
 - 2—No. 922P 14" x 22" Bass Drums, pearl @ \$122.00 **244.00**
 - 2—No. 942P 8" x 12" Tom Toms, pearl @ \$62.50 **125.00**
 - 1—No. 950P 16" x 16" Tom Tom, Pearl and Legs..... **89.50**
 - 1—No. 952P 16" x 18" Tom Tom, Pearl and Legs..... **105.00**
 - 1 pr.—No. 2358P Tunable Bongos, pearl..... **52.50**
 - 1—No. 1027 Drummers "Seat Case", pearl (including zipper cover)..... **47.50**
 - 1—No. 1345 All-Angle, Tom Tom floor stand for 8" x 12" Tom Toms, chrome.. **14.00**
 - 1—No. 1346 Adjustable Bongo stand..... **10.00**
 - 1—No. 1121 Sock Pedal, chrome..... **19.50**
 - 1—No. 1363 Flat Base drum stand, chrome.. **9.95**
 - 1—No. 1400 Flat Base cymbal stand, chrome. **9.95**
 - 2—No. 1372 Shell Mount Cymbal Holders @ \$6.50 **13.00**
 - 1—No. 128C 4" Cow Bell, chrome plated..... **4.00**
 - 1—No. 129C 5" Cow Bell, chrome plated..... **4.00**
 - 2—No. 126 Single Cow Bell Holders @ \$1.50 **3.00**
 - 2—No. 201 Speed King pedals @ \$22.00..... **44.00**
 - 2 pr.—No. 1305 Shell Mount Folding Spurs, @ \$4.50..... **9.00**
 - 1 pr.—No. 192 Wire brushes..... **2.00**
 - 1 pr.—No. 318 Buddy Rich drum sticks..... **1.00**
 - 1 pr.—No. 344 Tympani sticks, per pair..... **5.50**
- Total.... \$887.40**

14" x 14" Floor Tom Tom in place of 16" x 16" size optional at same price—specify if desired

Introducing . . . THE HOLLYWOOD OUTFIT



SPARKLING GOLD PEARL ILLUSTRATED

● HERE IS THE LATEST IN TWIN TOM TOM DESIGN FOR TODAY'S MODERN DRUMMER

Once again Ludwig's advance design and creative imagination has developed the ideal outfit for today's modern jazz stylist. The "Hollywood" incorporates all top quality features including: triple flanged hoops, self-aligning tension casings and the sure-action snare strainer. Twin 8" x 12" tom toms are mounted on new retracting holder which provides complete angle and height adjustment.

No. 983P Hollywood Outfit, Choice of Pearl Finishes, less all cymbals **\$485.00**

No. 983PC Hollywood Outfit, Choice of Pearl Finishes, with all hardware chrome plated **\$520.00**

Cymbals Not Included—Excise Tax Extra

14" x 14" Floor Tom Tom in place of 16" x 16" size optional at same price—specify if desired

1—No. 908P 5" x 14" Snare Drum, choice of pearl	\$ 75.00
1—No. 922P 14"x22" Bass Drum, choice of pearl	122.00
2—No. 942P 8" x 12" Tom Toms, choice of pearl @ \$62.50	125.00
1—No. 950P 16" x 16" Tom Tom, Pearl and Legs	89.50
1—No. 781 Retracting Double Tom Tom Holder	20.00
1—No. 1121 Sock Pedal, chrome	19.50
1—No. 1363 Flat Base drum stand, chrome . .	9.95
2—No. 1400 Flat Base cymbal stand, chrome @ \$9.95	19.90
1—No. 201 Speed King pedal	22.00
1 pr.—No. 1305 Shell Mount Folding Spurs, pair	4.50
1 pr.—No. 193 Wire brushes	2.00
1 pr.—No. 318 Buddy Rich drum sticks	1.00
Total	\$510.35

Ludwig

THE "Super Classic" OUTFIT



WHITE MARINE PEARL ILLUSTRATED

• FOR THE DISCRIMINATING DRUMMER

This popular outfit has proven itself with top professionals everywhere. Superb design and craftsmanship with built-in quality to meet every exacting demand. Outfit features the new all-metal Super Ludwig snare drum acclaimed for its crisp, live tone. Shell mount holders and spurs provide instant setup. Modern flat base stands and the famous Ludwig Speed King pedal are included.

(Available with matching pearl snare drum at the same price)

No. 980P Super Classic Outfit. Choice of Pearl Finishes, Less Cymbals **\$432.50**

No. 980PC Super Classic Outfit, Choice of Pearl Finishes, with all hardware chrome plated. **460.00**

Cymbals Are Not Included—Excise Tax Extra

14" x 14" tom tom may be substituted at no change in price—specify!

1—No. 400	5" x 14" All-Metal Snare.....	\$ 88.00
1—No. 922P	14" x 22" Bass Drum, pearl....	122.00
1—No. 944P	9" x 13" Tom Tom, pearl.....	64.50
1—No. 950P	16" x 16" Tom Tom, Pearl and Legs.....	89.50
1—No. 782	Shell Mount Tom Tom Holder.	12.00
1—No. 1121	High Hat Pedal Stand.....	19.50
1—No. 1363	Flat Base Snare Drum Stand...	9.95
1—No. 1400	Floor Stand Cymbal Holder...	9.95
1—No. 1372	Shell Mount Cymbal Holder...	6.50
1—No. 129	5" Clear Tone Cow Bell.....	2.25
1—No. 133	Single Cow Bell Holder.....	1.75
1—No. 201	Speed King Pedal.....	22.00
1 pr.—No. 1305	Folding Spurs, shell mount....	4.50
1 pr.—No. 191	Red Rubber Brushes.....	1.80
1 pr.—No. 318	Buddy Rich model sticks.....	1.00

TOTAL VALUE.....\$455.20

DRUM CO. 1728 No. Damen Ave.
Chicago 47, Illinois



OYSTER PINK PEARL ILLUSTRATED

	<i>Nickel</i>	<i>Chrome</i>
No. 988L—"DOWNBEAT" Outfit, choice of lacquer colors, less cymbals.....	\$335.00	\$367.50
No. 988P—"DOWNBEAT" Outfit, choice of pearl, less cymbals.....	389.50	421.00

Federal Excise Tax Extra



SPARKLING SILVER PEARL ILLUSTRATED

	<i>Nickel</i>	<i>Chrome</i>
No. 986L—NEW YORKER Outfit, choice of lacquer colors, less cymbals.....	\$302.50	\$322.50
No. 986P—NEW YORKER Outfit, choice of pearl, less cymbals.....	338.50	358.50

Federal Excise Tax Extra

The "DOWNBEAT" Outfit.

A modern, compact outfit featuring the latest in drum sizes with 4" x 14" snare, 14" x 20" bass, 8" x 12" and 14" x 14" tom toms. Ideal for the progressive drummer playing "one-nighters." Incorporates all of Ludwig's top quality features including: triple flanged hoops, shell mount holders and spurs, flat base stands and the great blue "Speed-Master" pedal.

Available in choice of pearl or lacquer finishes.

Following list is in pearl finish:

1—No. 906P—4" x 14" "Downbeat" snare drum.....	<i>Nickel</i> \$ 64.00
1—No. 920P—14" x 20" Classic Bass drum.....	114.00
1—No. 942P—8" x 12" Classic tom tom..	62.50
1—No. 948P—14" x 14" tom tom with legs mounted.....	82.00
1—No. 782 —Shell mount tom tom holder.....	12.00
1—No. 1372—Shell mount cymbal holder.....	6.50
1—No. 1400—Floor stand cymbal holder.....	9.95
1—No. 1363—Flat base snare drum stand.....	9.95
1—No. 1121—High hat sock cymbal stand.....	19.50
1—No. 133 —Cow bell holder.....	1.75
1—No. 129 —5" Clear tone cow bell....	2.25
1—No. 205 —Blue Speed-Master pedal..	18.00
1 pr.—No. 1305—Shell mount folding spurs.	4.50
1 pr.—No. 191 —Red rubber wire brushes..	1.80
1 pr.—No. 319 —Morello model sticks.....	1.00
Total....	\$409.70

The "NEW YORKER" Outfit

A new three piece outfit featuring the popular all-metal Super Ludwig snare drum. The compact 12" x 22" bass and 8" x 12" tom tom provide handling ease for the jobbing drummer. Disappearing cymbal holder places the ride cymbal in ideal playing position. Shell mount holders and spurs, flat base stands and the famous Speed King pedal are added quality features.

Available in choice of pearl and lacquer finishes.

Listed in pearl as follows:

1—No. 400 —5" x 14" All-metal snare drum.....	<i>Nickel</i> \$ 88.00
1—No. 921P—12" x 22" Classic bass drum.....	117.00
1—No. 942P—8" x 12" Classic tom tom.	62.50
1—No. 782 —Shell mount tom tom holder.....	12.00
1—No. 1380—Disappearing cymbal holder.....	4.00
1—No. 133 —Cow bell holder.....	1.75
1—No. 129 —5" Cow bell.....	2.25
1—No. 201 —Speed King pedal.....	22.00
1—No. 1400—Floor stand cymbal holder.....	9.95
1—No. 1363—Flat base snare drum stand.....	9.95
1—No. 1121—High hat sock cymbal stand.....	19.50
1 pr.—No. 1305—Shell mount folding spurs	4.50
1 pr.—No. 3A —Snare drum sticks.....	1.00
1 pr.—No. 191 —Red rubber wire brushes..	1.80
Total....	\$356.20

Ludwig DRUM CO.

The "CLUB DATE" Outfit

Here is a complete four piece outfit for the discriminating young artist. All drums are separate tension and equipped with streamlined self-aligning tension casings. Shell mount folding spurs and disappearing cymbal holder make set-up fast and easy. Top line flat base snare stand and the red Speed Master pedal included. A quality outfit at a moderate price.

Available in choice of pearl or lacquer finishes.

1—No. 908L—5" x 14" "Jazz Festival" snare.....	Nickel	\$ 65.00
1—No. 3246—14" x 22" Sep. ten. bass drum.....		82.00
1—No. 444L—9" x 13" Sep. ten. tom tom.....		47.00
1—No. 446L—12" x 15" Sep. ten. tom tom with legs.....		56.00
1—No. 45 —Hoop mount tom tom holder.....		6.00
1—No. 1363—Flat base snare drum stand.....		9.95
1—No. 1380—Disappearing cymbal holder.....		4.00
1—No. 129 —5" Clear tone cow bell....		2.25
1—No. 133 —Cow bell holder.....		1.75
1—No. 252 —Red Speed-Master pedal.		15.00
1 pr.—No. 1305—Folding spurs, mounted..		4.50
1 pr.—No. 190A—White rubber covered wire brushes.....		1.80
1 pr.—No. 5A —Snare drum sticks.....		1.00
Total.....		\$296.25



	Nickel	Chrome
GREEN AND GOLD MULTI-COLORED LACQUER		
No. 996L—CLUB DATE Outfit, choice of lacquer colors, less cymbal.....	\$282.50	\$314.00
No. 996P—CLUB DATE Outfit, choice of pearl finishes, less cymbal.....	342.50	373.50

The "COMBO" Outfit

The "Combo" is designed for the ambitious student and young drummer who wishes to start with a professional style *separate tension* outfit. Built-in quality features include: triple flanged hoops, self-aligning tension casings, disappearing cymbal holder, shell mount spurs, flat base snare stand and the red Speed Master pedal.

Available in choice of pearl or lacquer finishes.

1—No. 908L—5" x 14" "Jazz Festival" snare.....	Nickel	\$ 65.00
1—No. 3246—14" x 22" Sep. ten. bass drum.....		82.00
1—No. 444L—9" x 13" Sep. ten. tom tom.....		47.00
1—No. 45 —Hoop mount "clip-on" tom holder.....		6.00
1—No. 1363—Flat base snare drum stand.....		9.95
1—No. 1380—Disappearing cymbal holder.....		4.00
1—No. 777 —Tunable tone block.....		2.25
1—No. 129 —5" Clear tone cow bell....		2.25
1—No. 1323—Bell and block holder....		2.25
1—No. 136 —Adjustable bass drum muffler.....		4.50
1—No. 252 —Red Speed-Master pedal.		15.00
1 pr.—No. 1305—Shell mount folding spurs		4.50
1 pr.—No. 190A—White rubber wire brushes		1.80
1 pr.—No. 5A —Snare drum sticks.....		1.00
1—No. 1052—Elementary drum instructor.....		.50
Total.....		\$248.00



	Nickel	Chrome
BLUE AND SILVER MULTI-COLORED LACQUER		
No. 998L—COMBO OUTFIT, choice of lacquer colors, less cymbal.....	\$235.00	\$263.00
No. 998P—COMBO OUTFIT, choice of pearl finishes, less cymbal.....	280.00	308.00

Cymbals not included in price of outfits. Federal excise tax extra. No substitutions or omissions allowed when ordering the complete outfit.



BLACK AND GOLD MULTI-COLORED LACQUER

No. 1762—"SPOTLIGHT" Outfit, choice of lacquer colors—blue & silver; black & gold; white or black; green & gold
Note: Cymbal Included With Outfit

Nickel Chrome

\$167.00 \$187.50

Federal Excise Tax Extra

The "SPOTLIGHT" Outfit

Quality and economy are built into this popular low price outfit. The modern separate tension snare drum blends harmoniously with the streamlined single tension bass drum. Shell mount folding spurs and a disappearing cymbal holder are added features. The rich, high-gloss lacquer finish has been polished to a shimmering luster. Here is the ideal outfit for the beginning drummer.

- 1—No. 491L —5" x 14" Pioneer model snare..... \$ 49.00
- 1—No. 3266L—14" x 22" Singl. tension bass drum..... 76.00
- 1—No. 210 —10" Ludwig cymbal, thin 10.00
- 1—No. 129 —5" Cow bell..... 2.25
- 1—No. 777 —Tone block..... 2.25
- 1—No. 1323 —Bell and block holder.... 2.25
- 1—No. 252 —Red Speed-Master pedal 15.00
- 1—No. 1357 —Snare drum stand..... 6.75
- 1 pr.—No. 1305 —Shell mount folding spurs..... 4.50
- 1 pr.—No. 7A —Snare drum sticks..... 1.00
- 1 pr.—No. 190A —White rubber covered wire brushes..... 1.80
- 1—No. 1052 —Elementary drum instructor..... .50
- 1—No. 1380 —Disappearing cymbal holder..... 4.00
- Total.... **\$175.30**



BLUE AND GOLD MULTI-COLORED LACQUER

No. 992L—"HOBBY" Outfit, light blue & gold multi-color as illustrated or choice of light blue & silver; black & gold; blue & silver, white or black lacquer....
Note: Cymbal Included With Outfit

Nickel Chrome

\$146.00 \$166.00

Federal Excise Tax Extra

The "HOBBY" Outfit

Here is a real value . . . a Ludwig quality outfit at an economical price. The Hobby outfit has all the features of the more expensive sets including a separate tension self-aligning snare drum with original triple flanged hoops, positive "Pioneer" throw-off, and nylon bearing Junior speed pedal. The outfit comes complete with the Ludwig cymbal illustrated and with "Playon" plastic heads. The greatest outfit buy on the market!

- 1—No. 905L —3" x 13" "Jazz Combo" snare..... \$ 46.00
- 1—No. 829L —12" x 20" Sing. tension bass drum..... 65.00
- 1—No. 206 —Junior speed pedal..... 12.00
- 1—No. 210 —10" Ludwig cymbal, thin 10.00
- 1—No. 1374 —Cymbal holder with bracket..... 4.00
- 1—No. 1357 —Snare drum stand..... 6.75
- 1—No. 133 —Cow bell holder..... 1.75
- 1—No. 129 —5" Cow bell..... 2.00
- 1 pr.—No. 190A—White rubber covered wire brushes..... 1.80
- 1 pr.—No. 3A —Snare drum sticks..... 1.00
- 1—No. 1052 —Elementary snare drumming..... .50
- 1 pr.—No. 1301 —Giant bass drum spurs... 3.00
- Total.... **\$153.80**

Ludwig

DRUM CO.

1728 No. Damen Ave.
 Chicago 47, Illinois

For the finest in percussion instruments... LUDWIG... played by
the famous Northwestern University Wildcat Band, John Paynter, director.



most famous name on drums!

No. 972P—12" x 15"



*Multi-Sparkle** Red and Silver



No. 967P—12" x 17"

SUPER CLASSIC PARADE DRUMS

Ludwig Super Classic parade drums have long been the choice of leading musical organizations across the nation. Over fifty years of quality drum manufacturing have made this model the most popular on the market. Ludwig's 3 ply laminated shells are light in weight for easy carrying, yet are the strongest available. Solid rock-maple glue rings provide added protection against warping.

The new Ludwig *Multi-Sparkle** pearl illustrated on this page is available on *all* Ludwig drums at the same price as regular pearl. When ordering—specify outer color first, inner color second. *Multi-Sparkle* pearl finishes may only be obtained in any combination of sparkling pearl finishes.



No. 979P—10" x 28"
(Sling Included)

CLASSIC PARADE DRUMS (Specify Colors Desired)

	Nickel	Chrome
No. 970—10" x 14" Choice of Lacquer or Mahogany ..	\$67.00	\$73.00
No. 976—10" x 15" " " " " " " ..		
No. 972—12" x 15" " " " " " " ..	77.00	83.00
No. 973—12" x 16" " " " " " " ..		
No. 970P—10" x 14" Choice of Pearl finishes	79.00	85.00
No. 976P—10" x 15" " " " " " "		
No. 972P—12" x 15" " " " " " "	92.00	98.00
No. 973P—12" x 16" " " " " " "		

Classic throw-off extra.....\$5.00
Gut snares, extra..... 2.00

Two-tone wire-gut snares, extra....\$3.00
Wood hoops can be supplied at same price. Specify if desired.

CLASSIC TENOR DRUMS

	Nickel	Chrome
No. 965—12" x 15" Choice of Lacquer or Mahogany	\$77.00	\$ 83.00
No. 967—12" x 17" " " " " " "	80.00	86.00
No. 965P—12" x 15" Choice of Pearl finishes	92.00	98.00
No. 967P—12" x 17" " " " " " "	95.00	101.00

If plain or inlaid wood hoops desired on above, specify.

CLASSIC SCOTCH BASS DRUMS

	Nickel	Chrome
No. 978—10" x 26" Choice of Lacquer or Mahogany....	\$102.00	\$112.00
No. 979—10" x 28" " " " " " "	110.00	121.00
No. 978P—10" x 26" Choice of Pearl finishes	122.00	132.00
No. 979P—10" x 28" " " " " " "	131.00	141.00

Sticks and slings included.

Pearl inlaid counter hoops are standard on all pearl models.
Available at \$3.00 extra on mahogany or lacquer drums.

* Registered TradeMark

Ludwig DRUM



No. 3202P—12" x 15"



No. 3211P—12" x 17"

J. BURNS MOORE MODEL PARADE DRUMS

The popular J. Burns Moore Models feature the same quality construction as the "CLASSIC" line but are supplied with center mounted, self-aligning, separate tension casings. Ludwig's original triple-flanged hoops, instant snare throw-off and matched heads add to the high quality of this line. Available in your choice of pearl or lacquer colors with either hard "bright" nickel or glistening "triple" chrome plated hardware. Slings and sticks or beaters are included with each drum.

These models are available in any combinations of *Multi-Sparkle** pearl finishes at same price as standard pearl finishes. Specify outer color first—inner color second.

J. BURNS MOORE MODEL PARADE DRUMS

	Nickel	Chrome
No. 3092—10" x 14" Choice of Lacquer or Mahogany.	\$63.00	\$69.00
No. 3200—10" x 15" " " " " " "		
No. 3202—12" x 15" " " " " " "	73.00	79.00
No. 3203—12" x 16" " " " " " "		
No. 3092P—10" x 14" Choice of Pearl finishes.....	75.00	81.00
No. 3200P—10" x 15" " " " " " ".....		
No. 3202P—12" x 15" " " " " " ".....	89.00	94.00
No. 3203P—12" x 16" " " " " " ".....		
Classic throw-off extra.....	\$5.00	
Gut snares extra.....	2.00	
		Two-tone Wire-gut snares, extra. \$3.00
		If wood hoops desired, specify.

	Nickel	Chrome
No. 3210—12" x 15" Choice of Lacquer or Mahogany ..	\$73.00	\$79.00
No. 3211—12" x 17" " " " " " " ..	76.00	82.00
No. 3210P—12" x 15" Choice of Pearl finishes.....	89.00	94.00
No. 3211P—12" x 17" " " " " " " ..	91.00	97.00

If plain or inlaid hoops desired on above, specify.

J. BURNS MOORE SCOTCH BASS DRUMS

	Nickel	Chrome
No. 3214— 8" x 26" Choice of Lacquer or Mahogany.	\$ 97.00	\$107.00
No. 3218—10" x 26" " " " " " " ..		
No. 3215— 8" x 28" " " " " " " ..	106.00	116.00
No. 3220—10" x 28" " " " " " " ..		
No. 3214P— 8" x 26" Choice of Pearl finishes.....	117.00	127.00
No. 3218P—10" x 26" " " " " " " ..		
No. 3215P— 8" x 28" " " " " " " ..	126.00	136.00
No. 3220P—10" x 28" " " " " " " ..		

Pearl inlaid counter hoops are standard on all pearl models.
Available at \$3.00 extra on mahogany or lacquer drums.

* Registered Trade Mark



No. 3220P—10" x 28"
(Sling Included)

No. 3082—10" x 14"



No. 3088—12" x 15"



No. 3230—10" x 28"
(Sling Included)

CHAMPION SINGLE TENSION PARADE DRUMS

The CHAMPION single tension models are quality instruments in the medium price range. Sturdy laminated shells are properly reinforced with solid rock-maple glue rings. Streamlined die cast tension casings are center mounted like the more expensive models. Available in your choice of pearl or lacquer colors with either hard "bright" nickel or glistening "triple" chrome plated hardware. Pearl inlaid counter hoops are standard on all pearl models and are available on lacquer models at \$1.50 extra per parade or tenor drum and \$3.00 extra per bass drum.

Matching Scotch bass, tenor and parade drums will add color and snap to your marching percussion section.

CHAMPION PARADE DRUMS

	Nickel	Chrome
No. 3082—10" x 14" Choice of Lacquer or Mahogany . . .	\$53.00	\$58.00
No. 3085—10" x 15" " " " " " " . . .	60.00	65.00
No. 3084—12" x 15" " " " " " " . . .	60.00	65.00
No. 3082P—10" x 14" Choice of Pearl finishes	65.00	70.00
No. 3085P—10" x 15" " " " " " "	75.00	80.00
No. 3084P—12" x 15" " " " " " "	75.00	80.00
Gut snares extra	\$2.00	

CHAMPION TENOR DRUMS

	Nickel	Chrome
No. 3087—10" x 15" Choice of Lacquer or Mahogany . . .	\$53.00	\$58.00
No. 3088—12" x 15" " " " " " " . . .	60.00	65.00
No. 3087P—10" x 15" Choice of Pearl finishes	65.00	70.00
No. 3088P—12" x 15" " " " " " "	73.00	78.00

Sticks and sling included.

CHAMPION SCOTCH BASS DRUMS

	Nickel	Chrome
No. 3226— 8" x 26" Choice of Lacquer or Mahogany . . .	\$ 92.00	\$102.00
No. 3228—10" x 26" " " " " " " . . .	98.00	108.00
No. 3227— 8" x 28" " " " " " " . . .	112.00	122.00
No. 3230—10" x 28" " " " " " " . . .	118.00	128.00
No. 3226P— 8" x 26" Choice of Pearl finishes	112.00	122.00
No. 3228P—10" x 26" " " " " " "	118.00	128.00
No. 3227P— 8" x 28" " " " " " "	118.00	128.00
No. 3230P—10" x 28" " " " " " "	118.00	128.00

Pearl inlaid counter hoops are standard on all pearl models. Available at \$3.00 extra on mahogany or lacquer drums.

Ludwig DRUM

No. 3061—10" x 14"



No. 3065—10" x 15"

STADIUM MODEL PARADE DRUMS

These snappy single tension models are equipped with stud center supports and sturdy, streamlined tension hooks. Standard laminated shell is strongly reinforced with rock-maple glue rings. Full-drop throw-off strainer is easily adjusted for any desired tone or response.

Available in your choice of Ludwig's hard "bright" nickel or glistening "triple" chrome plated hardware and in either mahogany, lacquer, or multi-color lacquer finishes. Plain hoops are standard, pearl inlaid hoops available at \$1.50 extra on parade and tenor drums, \$3.00 extra for bass drums. Not supplied in pearl finishes. Here is true value in the low price field.

STADIUM MODEL PARADE DRUMS		<i>Nickel</i>	<i>Chrome</i>
No. 3061—10" x 14"	Choice of Lacquer or Mahogany, Eight Rods	\$42.50	\$45.00
No. 3062—10" x 14"	Choice of Lacquer or Mahogany, Six Rods	39.50	42.00
No. 3071—12" x 15"	Choice of Lacquer or Mahogany...	49.50	52.00

STADIUM MODEL TENOR DRUMS		<i>Nickel</i>	<i>Chrome</i>
No. 3065—10" x 15"	Choice of Lacquer or Mahogany...	\$42.50	\$45.00

STADIUM MODEL BASS DRUMS		<i>Nickel</i>	<i>Chrome</i>
No. 3094— 8" x 26"	Choice of Lacquer or Mahogany..	\$81.00	\$ 87.00
No. 3096—10" x 26"	" " " " " ..		
No. 3095— 8" x 28"	" " " " " ..	95.00	101.00
No. 3097—10" x 28"	" " " " " ..		

Pearl inlaid hoops extra..... **\$3.00**

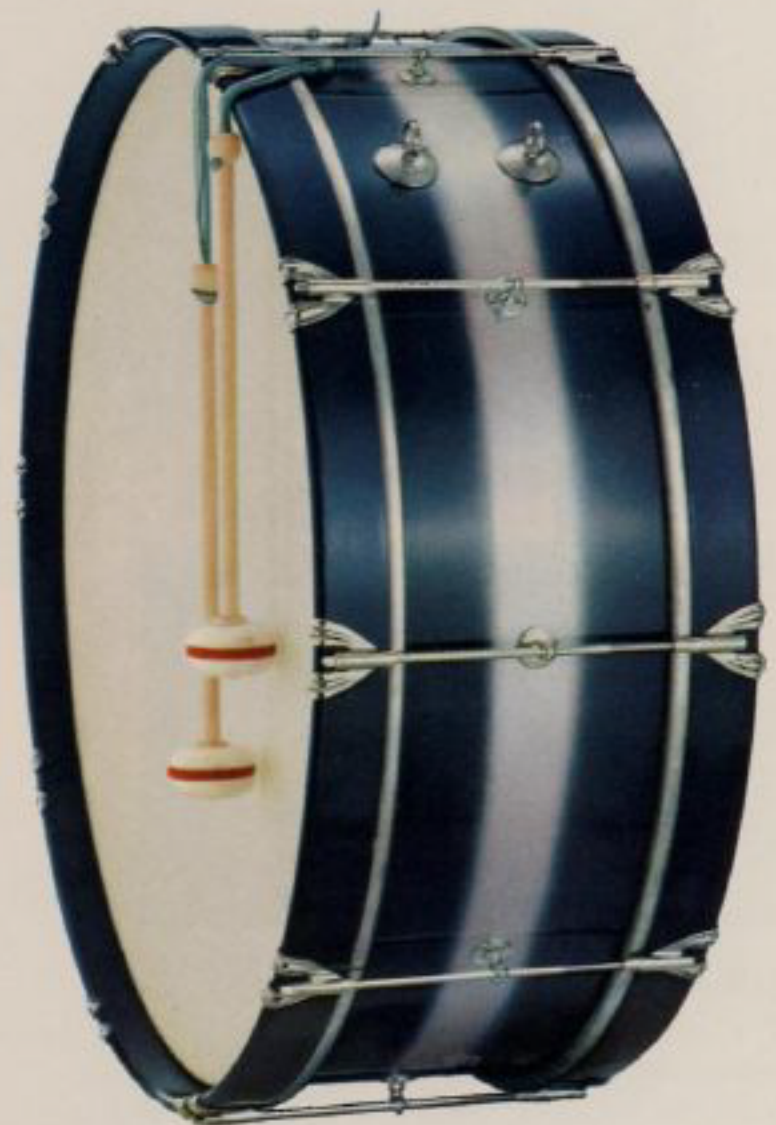

No. 3097—10" x 28"
(Sling Included)

Ludwig ECONOMY PARADE DRUMS



THE PREP MODEL

Traditional Ludwig quality craftsmanship and the finest of materials are combined in producing the popular PREP MODEL parade drums. These superb marching models are designed for the beginning drummer at an economical price. The three ply laminated shell is firmly reinforced with hard rock-maple glue rings. Solid maple counter hoops are tensioned by six single tension key rods. Modern contour double claw hooks provide even head tension. Instant throw-off strainer offers finger-tip snare tension adjustment.

Here is real value in a low price student line instrument. Available in either lacquer or mahogany finish.

Nickel Chrome

No. 3062—10" x 14" PREP MODEL.....\$39.50 \$42.00



THE CUB MODEL

The CUB MODEL is designed for use by youngsters of Grade School age and offers finest quality in the economy line. Three ply laminated shell is reinforced with rock maple glue rings. Six single tension key rods and contour double claw hooks provide even head tension. Single screw snare strainer allows full snare control. Solid maple counterhoops in natural finish add to the lasting beauty of this model. Sticks and sling included. Available in mahogany finish only.

No. 2440—9" x 13" CUB MODEL, nickel only.....\$34.00

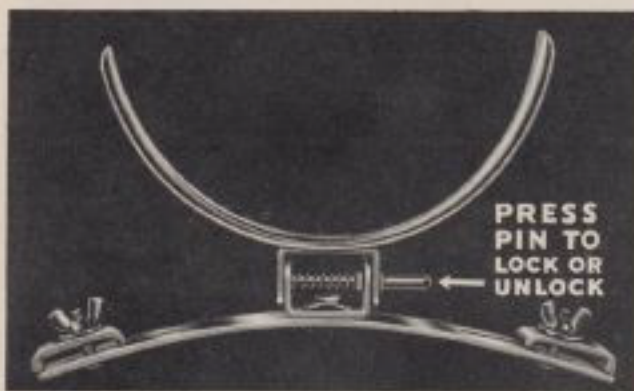

LEG RESTS

The new Ludwig LEG REST is designed to reduce leg fatigue and eliminate bruising knocks from the drum. Completely adjustable, it holds drum at proper playing angle for any cadence. A convenient pin lock snaps leg rest in open or closed position.

Available in either rod mount or shell mount models. Easy to install on your present drum. Rod mount leg rest not recommended on Super Classic parade models.

Nickel Chrome

No. 475—Shell Mount Leg Rest.....	} \$4.00 \$5.00
No. 476—Rod Mount Leg Rest.....	



NEW TENOR DRUM "VERTI-HOLDER"

The Ludwig originated VERTI-HOLDER has proven popular with leading marching bands across the nation. Holder places tenor drum in vertical position for playing ease and added flash. It offers a "new look" to the drum section. Holder folds against shell when not in use. Supplied in white lacquer only complete with eye hooks, sling and waist strap.

No. 477—VERTI-HOLDER, white lacquer only.....\$20.00



LUDWIG—Most Famous Name ON Tympani!

... as played by Edward M. Metzenger, Chicago Symphony Orchestra



More musical organizations choose Ludwig tympani for superb tone and workmanship!

MORE PROFESSIONALS CHOOSE *Ludwig*

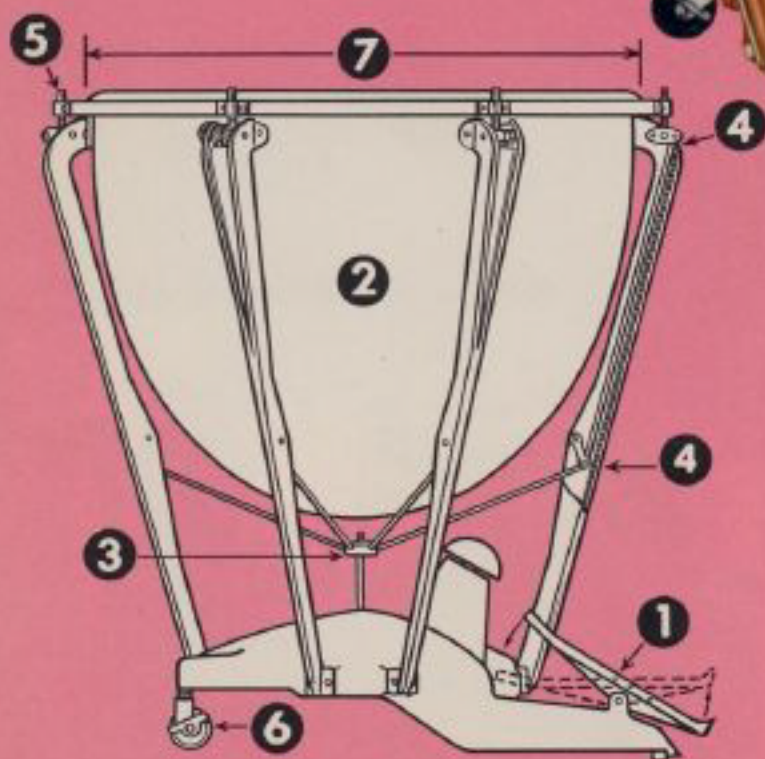

EXCLUSIVE FEATURES OF THE NEW PROFESSIONAL SYMPHONIC MODEL

1. Famous Ludwig *Balanced Action* pedal mechanism.
2. One-Piece *Parabolic* copper kettles for greater tone.
3. *External Tension* places all tuning mechanism on outside.
4. Sensitive bell crank and double linkage mechanism concealed in struts for maximum protection.
5. Eight key tension tuning rods provide clear playing surface for sticking ease.
6. All-directional roller wheels with built-in locks hold tympani in playing position.
7. The new 26" and 29" diameters provide greater tonal body throughout the entire range of the instruments.

THE NEW PROFESSIONAL SYMPHONIC MODEL

Wm. F. Ludwig continues to set the world's standard of tympani perfection by introducing the all new PROFESSIONAL SYMPHONIC MODEL. Designed and built to meet the exacting demands of today's top professional tympanists, the new Symphonic Model features the principal of *External Tension*. Now, all tuning mechanism is placed on the outside of the kettle.

Eight tension rods, pull rods and suspension struts provide a more accurate and sensitive tuning mechanism. Bell cranks and pull rods are concealed within the suspension struts for maximum protection. A system of double linkage connects the individual pull rods with a central spider and main pull rod beneath the kettle.

Selection of 26" and 29" diameters as standard provides greater tonal body at the extreme ends of each range. The exclusive Ludwig *Balanced Action* pedal assures fast, effortless tuning. Key tension rods leave playing surface clear for cross-sticking.

Here is the finest in tympani design and tonal response built by the leading manufacturer of pedal tuned tympani.

*No. 880—26" and 29" PROFESSIONAL SYMPHONIC MODEL TYMPANI, polished copper kettles, sticks and fibre head protectors included, per pair **\$690.00**
Federal excise tax, extra, net. **\$40.80**

Ludwig

TYMPANI THAN ANY OTHER MAKE



THE STANDARD SYMPHONY MODEL

In all musical history, no other tympani has enjoyed such great popularity as the Ludwig STANDARD SYMPHONY MODEL. Today, leading musical organizations the world over feature the incomparable tone and response of these fine instruments.

Ludwig's famous *Balanced Action* pedal provides instant, trouble-free tuning. Location of every tone is fast and effortless with no clumsy clutch mechanism to stick or squeak. Six sturdy suspension struts support the deep parabolic kettles offering maximum kettle resonance. New all-directional roller wheels provide easy portability and lock instruments into playing position.

Solid copper seamless kettles are hand buffed and polished to a mirror finish. Metal parts including rods and hoops are chrome plated. Sticks and fibre head protectors are included.

Provide your musical organization with a complete set of 4 Standard Symphony Model tympani to meet today's growing musical requirements.

*No. 890—25" and 28" STANDARD SYMPHONY MODEL TYMPANI, polished copper kettles, sticks and fibre head protectors included, per pair.....**\$590.00**
Federal excise tax, extra, net..... 34.80

Additional Symphony Model Sizes Fed. Tax

*No. 886—23" Symphony model tympani, each **\$320.00** \$18.75

*No. 887—30" Symphony model tympani, each **350.00** 20.55

*No. 889—32" Symphony model tympani, each **395.00** 23.25

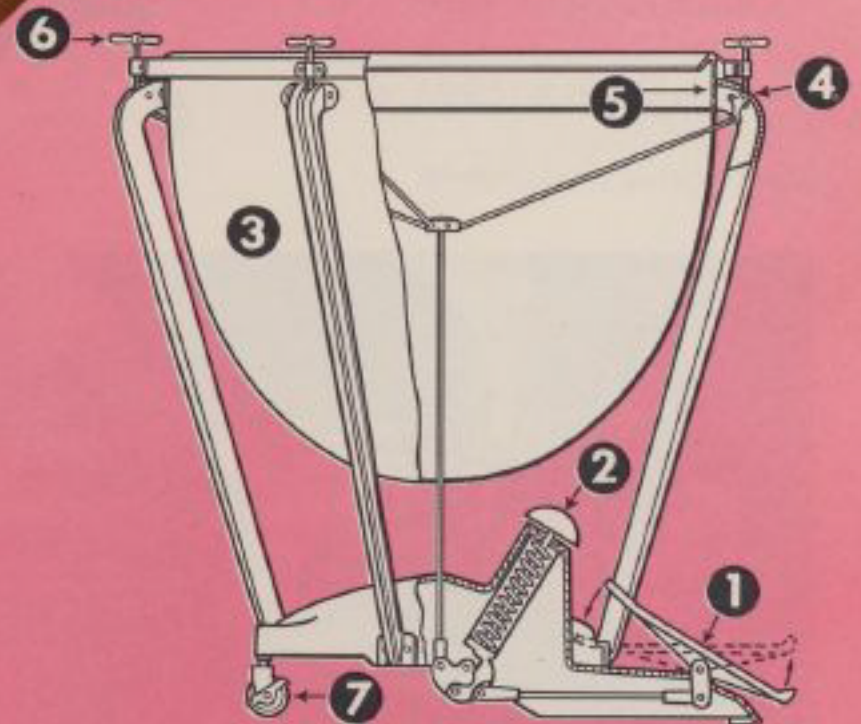

EXCLUSIVE FEATURES OF THE STANDARD SYMPHONY MODEL

1. Famous Ludwig *Balanced Action* pedal mechanism for fast, effortless tuning—located directly on the floor!
2. *Balanced Action* control knob and spring eliminates need for ratchets or clutch.
3. One-Piece *Parabolic* copper kettles for greater tone and resonance.
4. Bell cranks and links built into struts for maximum protection.
5. Solid steel reinforcement band supports head tension, maintaining even head tone at all times.
6. Small low-set tension handles are easy to reach yet away from sticks when playing.
7. All-directional roller wheels with built-in locks hold tympani in playing position.

Ludwig MANUFACTURERS OF PEDAL

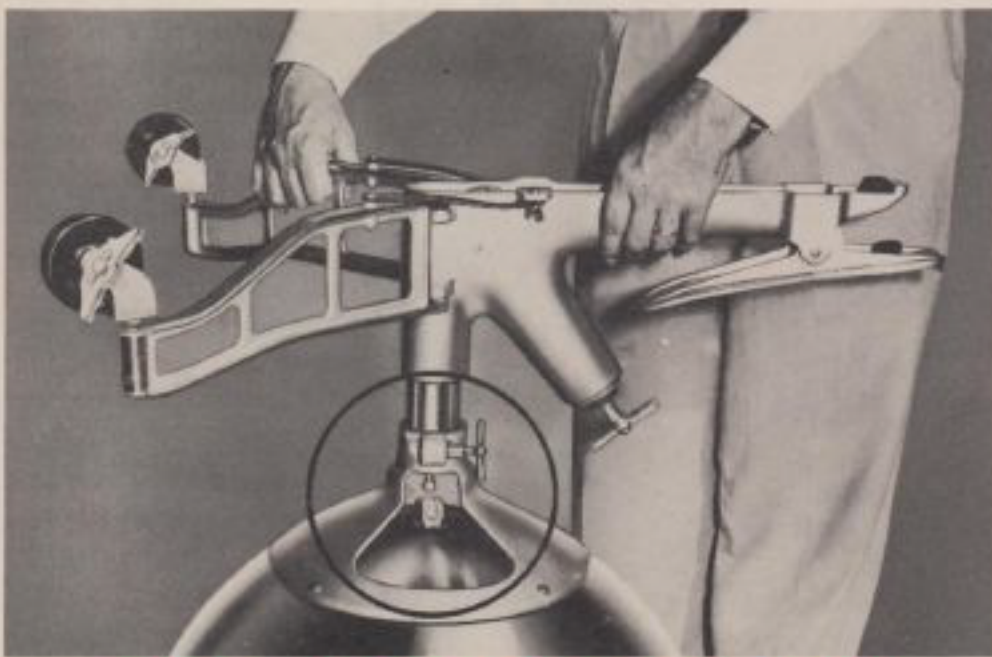

THE COMPLETELY PORTABLE TYMPANI

The Universal Model features the detachable base, enabling kettle and pedal mechanism to be packed separately. The new ball and socket connection between main pull rod and pedal is readily accessible for fast set up and dismantling when instruments are placed upside down. The wide-angle roller legs fold conveniently for packing.

UNIVERSAL MODEL IN ADDITIONAL SIZES

- *No. 897 —23" Satin finish copper kettle, each **\$245.00**
Federal excise tax extra, net..... 14.25
- *No. 894 —23" Polished copper kettle, each..... **260.00**
Federal excise tax extra, net..... 15.15
- *No. 898 —30" Satin finish copper kettle, each..... **300.00**
Federal excise tax extra, net..... 17.55
- *No. 895 —30" Polished copper kettle, each..... **315.00**
Federal excise tax extra, net..... 18.45

THE UNIVERSAL MODEL

The UNIVERSAL MODEL was originally built by Wm. F. Ludwig in the year 1919. It was designed for the discriminating professional incorporating Mr. Ludwig's natural *Balanced Action* tuning mechanism. Constant improvements in design and construction have kept pace with changing musical requirements. Today the modern Universal Model is ideal for school and professional use.

Tuning action is smooth and effortless—No cumbersome ratchet or clutch mechanism to stick and squeak. Floor level pedal tuning provides fast, accurate tone changes from seated or standing playing positions. Deep parabolic copper kettles assure superior tone and resonance throughout the entire chromatic range. All-directional roller wheels provide quick position adjustment, yet lock for final use. Kettle may be detached from base for transport. Rods and hoops chrome plated.

The Universal Model pedal tympani are the leading top quality artists' instruments in the lower price field.

*No. 892 —25" and 28" UNIVERSAL MODEL TYMPANI, copper kettles—satin finish, sticks and fibre head protectors included, per pair..... **\$485.00**
Federal excise tax extra, net..... 28.50

*No. 893—25" and 28" UNIVERSAL MODEL TYMPANI, copper kettles—polished and clear lacquered finish, sticks and fibre head protectors included, per pair..... **\$515.00**
Federal excise tax extra, net..... 30.30

SPECIAL SIZES QUOTED UPON REQUEST.

TUNED TYMPANI SINCE 1912

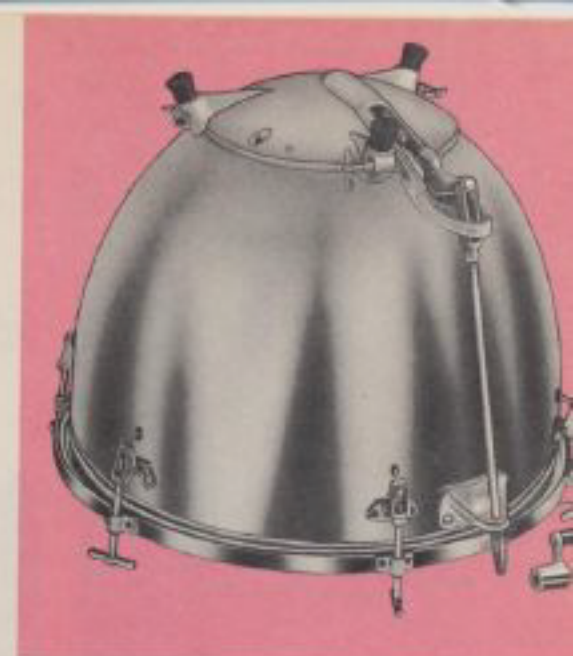

PORTABLE FEATURES

Legs retract completely into kettle for playing angle and height adjustment or transport. A minimum of mechanism for light weight portability. Ideal for traveling organizations as well as the "pit" drummer.

- *Single Screw Tuning*
- *Full Octave Range*
- *Deep Parabolic Kettles*
- *Height & Angle Adjustment*
- *Removable Tuning Handle*
- *Chrome Hoops and Rods*

THE LUDWIG MACHINE TYMPANI

Ludwig combines quality with economy in offering this entirely new concept in tympani design. The MACHINE MODEL is tuned by a single screw tuning mechanism operated by a hand crank mounted near playing surface. Rapid tuning is achieved by merely turning the handle to the right to raise pitch and to the left to lower pitch. A full octave range is easily obtainable on each instrument. Legs telescope into kettle for easy packing.

Ludwig Machine Tympani are designed for use in Junior High and Grade School organizations where budget and age of player is a factor. We also highly recommend the Machine Models as the third and fourth auxiliary drums to extend the range of your present set of pedal tympani.

*No. 870—25" and 28" MACHINE TYMPANI, copper kettles—satin finish, sticks and fibre head protectors included, per pair..... **\$360.00**
Federal excise tax extra, net..... 21.00

*No. 871—25" and 28" MACHINE TYMPANI, copper kettles—polished and clear lacquered finish, sticks and fibre head protectors included, per pair..... **\$390.00**
Federal excise tax extra, net..... 22.80

ADDED SIZES AND PRICES

*No. 874 —23" Satin finish copper kettle, each..... **\$184.50**
Federal excise tax extra, net..... 10.62

*No. 872 —23" Polished copper kettle, each..... **199.50**
Federal excise tax extra, net..... 11.52

*No. 875 —30" Satin finish copper kettle, each..... **235.00**
Federal excise tax extra, net..... 13.65

*No. 873 —30" Polished copper kettle, each..... **250.00**
Federal excise tax extra, net..... 14.55

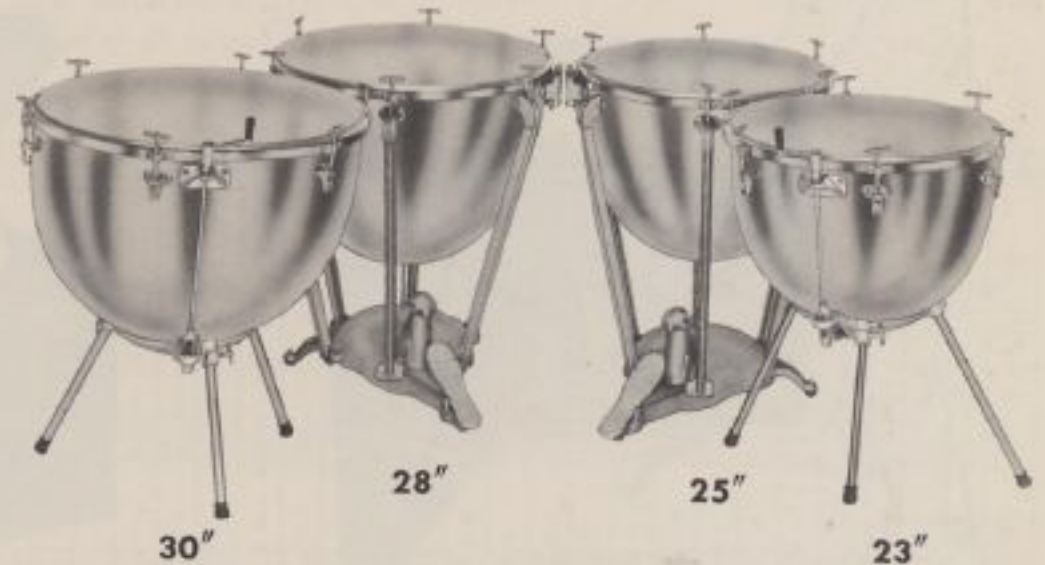

ADD AUXILIARY DRUMS TO YOUR PRESENT SET

Today's modern symphonic compositions require the use of four tunable tympani. Extend the over-all range of your present set of pedal tympani by adding the 23" and 30" Machine Model.

TYMPANI FEATURES AND ACCESSORIES



TYMPANI TUNING GAUGE

The exclusive Ludwig tuning gauge is essential in the performance of rapid changes in tuning and is ideal for use by the school tympanist. This handy accessory measures the movement of the counterhoop and translates this into accurate pitch readings by means of a pointer hand. The letters are moveable on a sliding track since the gauge must be hand set before each use when using calf skin heads. They may be mounted on any make or model and complete instructions with drawing accompany each pair of gauges. They are extremely accurate when used with the new LUDWIG plastic heads.

No. 899—Tuning gauges, per pair.....\$42.50

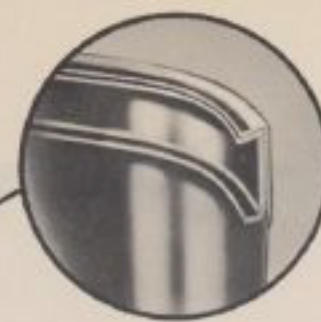

ONE-PIECE REINFORCEMENT RING

The rigid one-piece steel reinforcement ring around which Ludwig kettles are rolled provides immense strength where needed, assuring a clear *undistorted* tone.

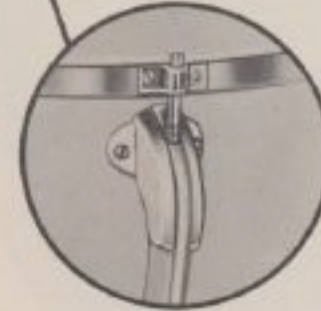

SUSPENSION STRUTS PROTECT MECHANISM

A solid shield of metal encompasses the vital bell-crank mechanism protecting it against dust, dirt, and bumps.



LOW-SET TUNING HANDLES

Small, low-set tuning handles are tucked out of the way—less chance of catching stick handles—makes cross-sticking easy!



FLOOR PEDAL TUNING

Floor tuning is the natural way of tuning. Simple heel-toe action moves head quickly from low to high tones. Cumbersome interfering locks are eliminated—glissandos extremely easy to obtain!

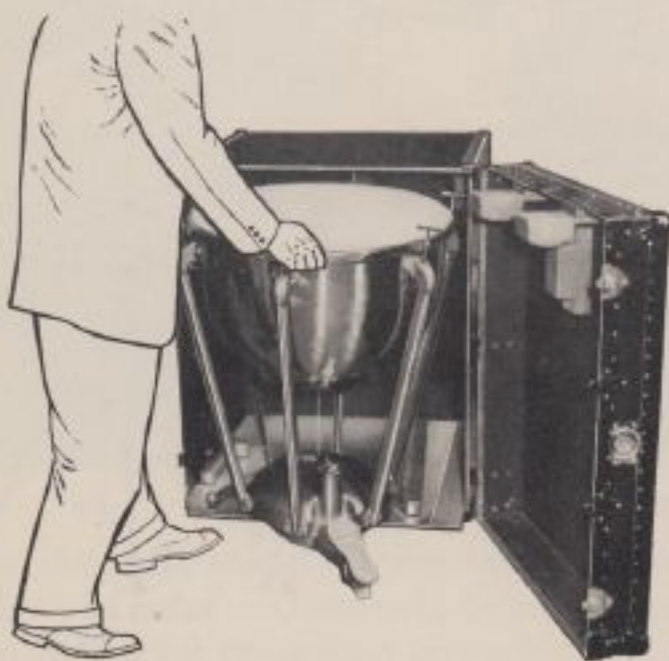

SYMPHONY TYMPANI TRUNKS

Professional quality tympani trunks reinforced and padded to offer maximum protection when traveling. Galvanized steel floor allows tympani to be rolled in for quick packing.

No. 891—Trunks for 25" and 28" Symphony model tympani, per pair, NET no discount....\$325.00

Prices for other sizes upon request.



UNIVERSAL TYMPANI TRUNKS

Top quality, heavy duty construction offers safety for your tympani when shipping. Suspension sling holds kettle—pedal detaches and is securely strapped into supporting blocks.

No. 888—Trunks for 25" and 28" Universal model tympani, per pair, NET no discount....\$275.00

Prices on other sizes upon request.



FULL DROP TYMPANI COVERS

Full drop covers provide maximum protection for your tympani when not in use. The 28" drop skirt keeps out dirt and dust and prevents unauthorized persons from tampering with the instrument.

No. 896—25" and 28" full drop covers, pair.....\$24.00

Other sizes, each.....\$12.00

NEW *Ludwig* ROTARY SLIDES

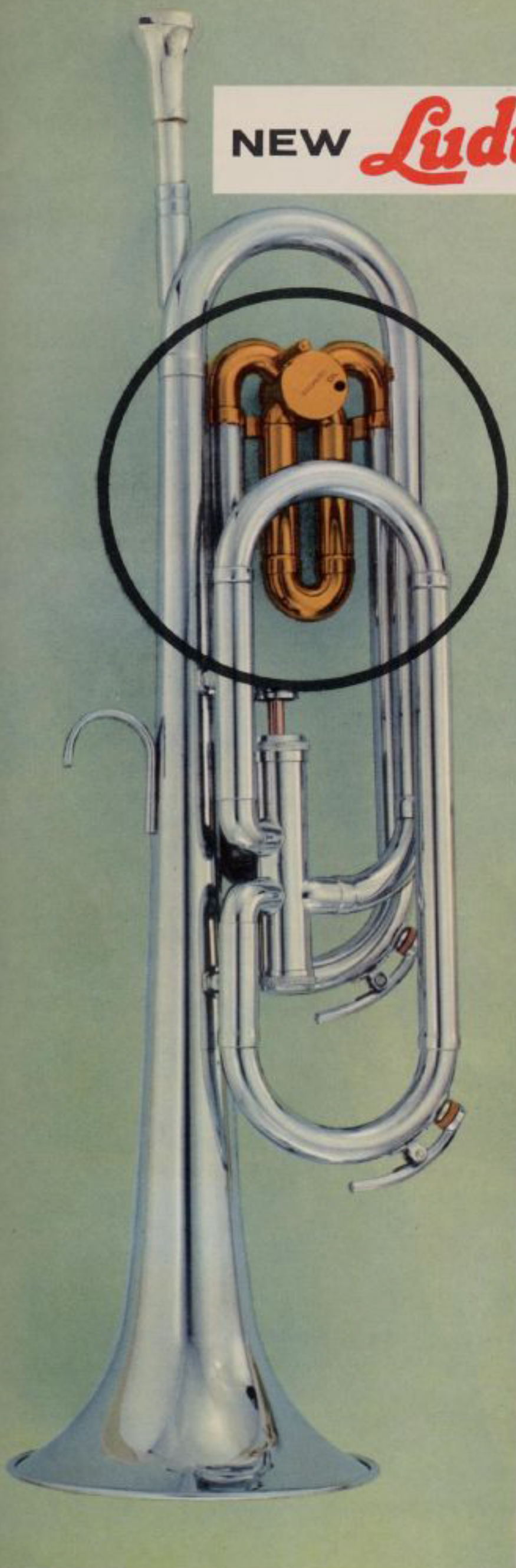

... INCREASES YOUR G-D BUGLE RANGE!

New Ludwig Rotary Lowers Pitch Full Tone!

Here you see illustrated the ideal application of the rotary slide to piston bugles. Quick-acting key lowers pitch one full tone and springs back into open position when released.

Fingering chart below indicates the additional notes available.

For best results—order Ludwig bugles equipped with rotaries as illustrated at left. They are designed to fit only Ludwig bugles. Order in either brass or chrome finish!



Rotary for Soprano and Tenor Bugles **\$18.00**



Rotary for Baritone, French Horn and Bass Bugles **\$23.00**

Prices of Ludwig Rotary Slides:

	Brass	Chrome
No. 530 —Rotary for Soprano and Tenor Bugles	\$18.00	\$21.00
No. 532 —Rotary for Baritone, French Horn and Bass Bugles	23.00	27.50

Soprano rotary slide pictured at left will fit only Ludwig bugles. Places G-D bugles in key of "F".

○ = Valve open + = Valve closed R = Rotary

- 1. G Bugle—Open tones
- 2. D Bugle—Valve Depressed.
- 3. G-D with valve and rotary.
- 4. Baritone and French Horn with valve and rotary.
- 5. Baritone and F. H. play these notes to complete the chromatic scale of line 4.



New Ludwig metal polish for cymbals—brass and chrome finished bugles.
No. 528—Metal Polish **\$1.00**



New Ludwig valve oil for piston bugles. Makes valve action fast, smooth, and silent.
No. 529—Valve oil **\$0.35**

Ludwig LINE OF QUALITY PISTON BUGLES



This bugle is built to exact United States Army specifications. It has a larger-than-usual bell for extra resonance. Only first quality brass is used. Well proportioned and easy to blow. Built in key of G with slide to F.

No. 515—Regulation G Bugle, Brass.....\$12.00
Length 15 inches

MOUTHPIECES

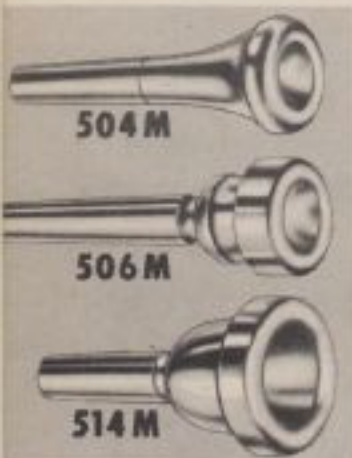

- No. 504M**—Regular soprano and tenor bugle mouthpieces.....\$4.50
- No. 506M**—DeLuxe Cushion-rim mouthpieces for soprano and tenor bugles..... 8.00
- No. 514M**—Baritone bugle mouthpiece..... 4.50
- No. 524M**—French Horn bugle mouthpiece. 4.50
- No. 526M**—Bass baritone bugle mouthpiece. 6.50

Federal Excise Tax Extra on Bugles 5%



BUGLE CASES

Protect your instruments from dents, nicks, and scratches with top quality bugle cases. Modern design plus the finest in materials and craftsmanship provide maximum bugle protection. The handsome brown leatherette cover and blending plush interior lining offer years of eye appeal.

- No. 504B**—Soprano bugle case.....\$15.00
- No. 514B**—Baritone bugle case..... 18.00
- No. 516B**—French Horn bugle case..... 20.00
- No. 518B**—Bass-Baritone bugle case..... 24.00

SOPRANO PISTON BUGLES

Length 20", Weight 28 ounces, Bell Diameter 5"

The Wm. F. Ludwig soprano is the easiest blowing bugle made. Designed for the modern day arrangements, this bugle can climb for those high notes with greater ease and accuracy. Built in the key of G with valve change to D and slide change to F. Rotary slide attachment may be easily added.

- No. 500**—Soprano Brass Finish, Clear Lacquer.....\$66.00
- No. 501**—Soprano Chrome Finish..... 84.00

BARITONE PISTON BUGLES

Length 23", Weight 53 ounces, Bell Diameter 6 1/4"

The Ludwig Baritone bugle completely fills out your arrangements with its increased range and tonal depth. The Baritone is used to support the French Horns or Bass-Baritone bugles, for rich harmony parts and for solo passages. Built in the key of G with valve change to D and slide change to F.

- No. 510**—Baritone, Brass Finish, Clear Lacquer.....\$104.00
- No. 511**—Baritone, Chrome Finish..... 130.00

FRENCH HORN PISTON BUGLES

Length 22", Weight 55 ounces, Bell Diameter 7 3/4"

The streamlined Ludwig French Horn bugle fills the gap between the soprano and baritone voices. The exceptional tonal qualities enable this bugle to be used for both harmony and solo melody parts. Built in the key of G with valve change to D and slide change to F.

- No. 520**—French Horn Brass Finish, Clear Lacquer.....\$160.00
- No. 521**—French Horn Chrome Finish..... 196.00

BASS-BARITONE PISTON BUGLES

Length 23", Weight 66 ounces, Bell Diameter 10"

The new Ludwig Bass-Baritone bugle provides those extra low tones needed to fill out your ensemble. The range is basically the same as the Baritone bugle with an extended lower register. It can be conveniently carried with one hand as valve and finger hook are both placed in most accessible position.

- No. 525**—Bass-Baritone, Brass Finish, Clear Lacquer.....\$180.00
- No. 526**—Bass-Baritone, Chrome Finish..... 244.00



Ludwig



model
no. 500



no. 510

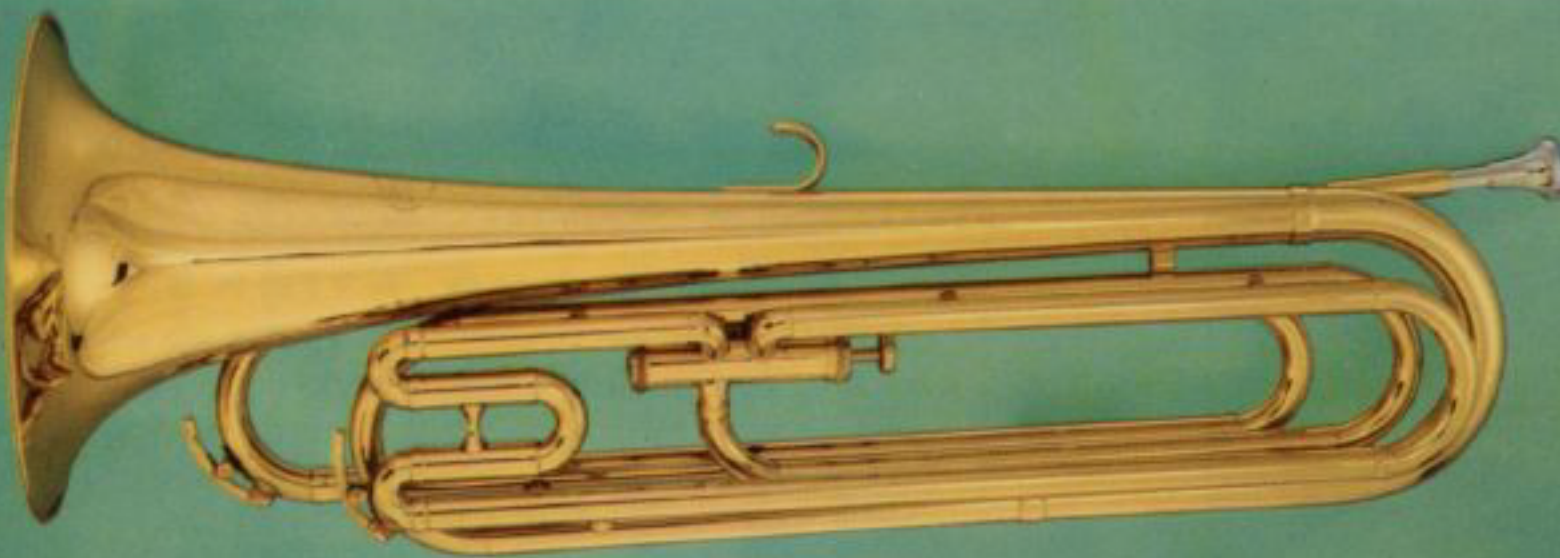

no. 520

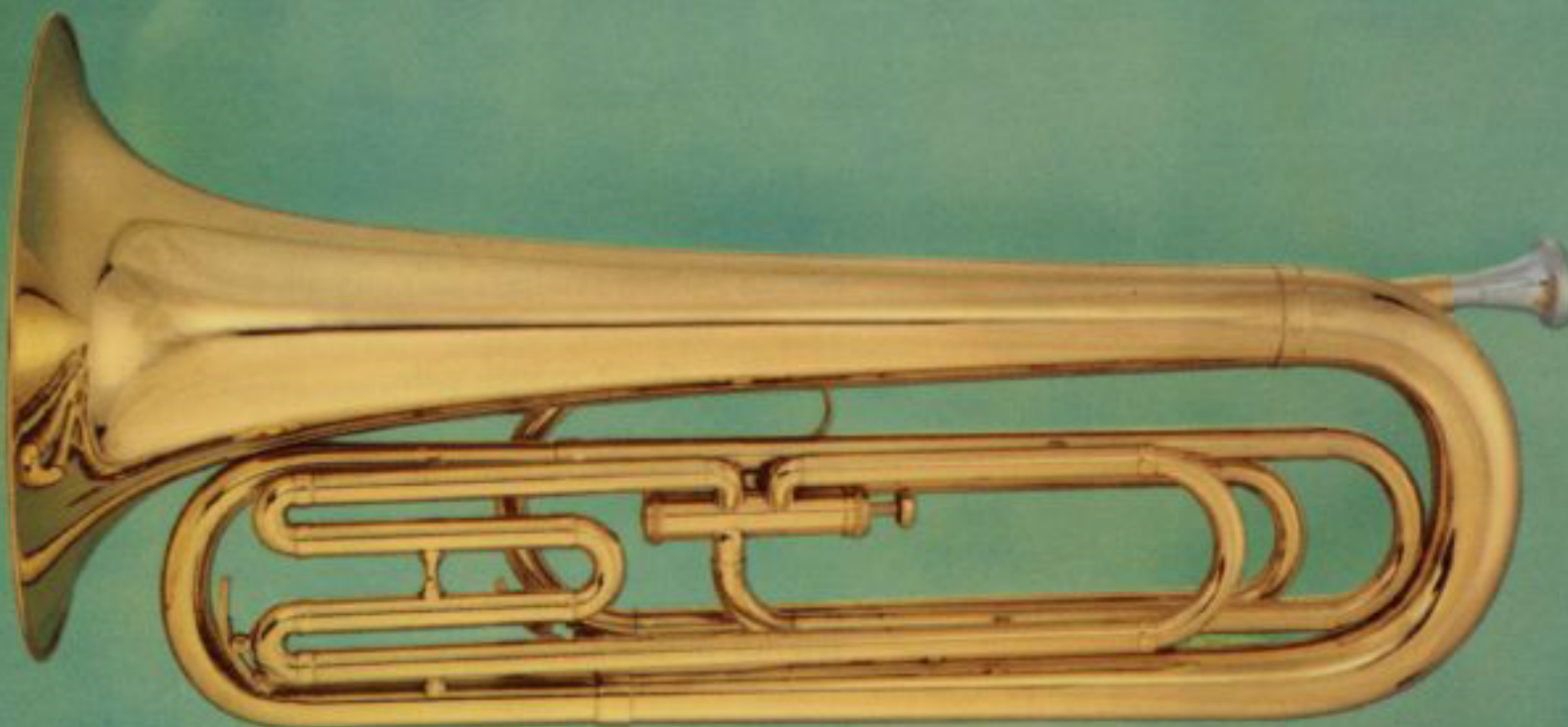

no. 525



MATCHED SNARE DRUM STICKS

The quality of Ludwig snare drum sticks is unsurpassed. They are cut from select close-grained white hickory, carefully sanded, filled and hand-dipped in highgloss white lacquer. Each stick is rolled and matched in pairs before sealing in our exclusive air-tight plastic bags. LUDWIG sticks are player tested . . . player approved! "A" stands for orchestra; "B" for band; and "S" for street models.

318

No. 318—Buddy Rich model, pair \$1.00

319

No. 319—Joe Morello model, pair \$1.00

1A

No. 1A —Orchestra model, pair \$1.00

2A

No. 2A —Orchestra model, pair \$1.00

3A

No. 3A —Orchestra model, pair \$1.00

4A

No. 4A —Ray Bauduc model, pair \$1.00

5A

No. 5A —Orchestra model, pair \$1.00

6A

No. 6A —Pencil model, pair \$1.00

BLUE END STICKS

Only the very finest straight-grained sticks are selected as Blue End models. Carefully matched in pairs and sealed in air-tight plastic bags, Blue End sticks are available in any model. When ordering specify "BE" along with number of stick desired. \$1.50

7A

No. 7A —Orchestra model, pair \$1.00

9A

No. 9A —Orchestra model, pair \$1.00

1B

No. 1B —Band model, pair \$1.00

2B

No. 2B —Band model, pair \$1.00

5B

No. 5B —Band model, pair \$1.00

1S

No. 1S —Street model, pair \$1.00

2S

No. 2S —Street model, pair \$1.00

3S

No. 3S —Street model, pair \$1.00

No. 317—Timbales sticks, pair \$1.00

317

STICKS and BEATERS

Ludwig sticks and beaters are hand-crafted to professional requirement. Lamb's wool and felt beaters are hand-sewn by experts of long experience. Specify these models when ordering!

BASS DRUM BEATERS

- No. 319 —Short model, double end wool concert beater\$5.25
- No. 320 —Long model, double end wool concert beater..... 5.25
- No. 322 —Double end felt marching beater, each 4.25
- No. 323 —Single end felt ball beater, each..... 3.75
- No. 323S—Single end felt beater with thong, each 5.00
- No. 330—Lamb's wool Scotch bass beaters, pair 7.25
- No. 331—Felt ball Scotch bass beaters, pair..... 6.25
- No. 334—Solid wood bass drum beaters, per pair. 5.25

TENOR STICKS

- No. 332—Lamb's wool Tenor drum beaters, pair \$6.75
- No. 333—Felt ball Tenor drum beaters, pair... 5.75
- No. 1610—Hard felt tenor sticks 5.75
- No. 337—Champion model wood tenor sticks with rubber handles, per pair 5.25

TYMPANI STICKS

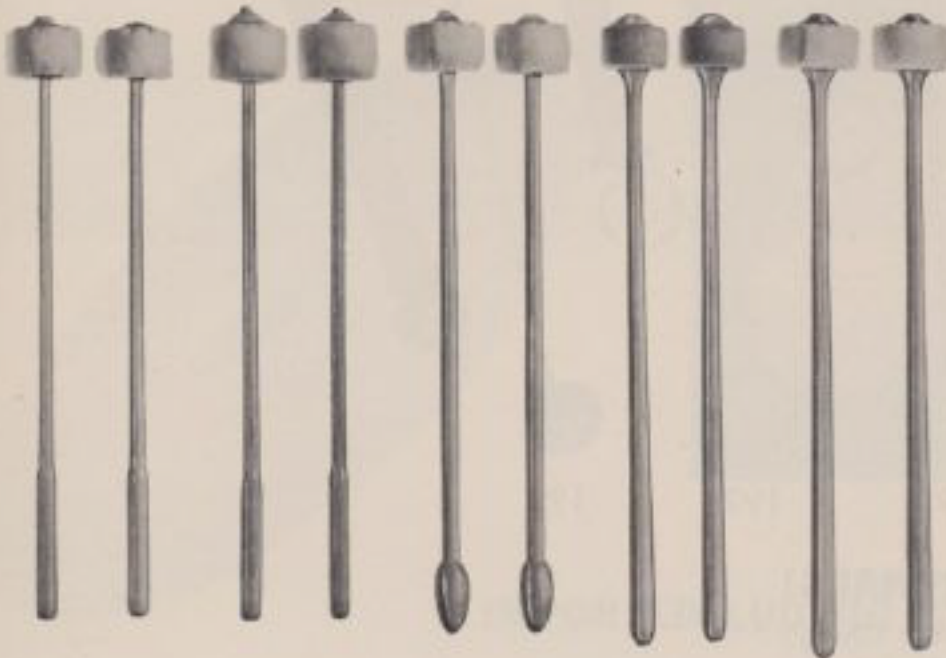

- 341— 325 344 345 346
- No. 341—Metzenger model, medium ball, pair...\$5.25
- No. 325—Soft ball tympani sticks, pair..... 5.25
- No. 344—Professional model, double ends, pair.. 5.75
- No. 345—Solid felt tympani sticks, hard, pair.... 4.00
- No. 346—Symphonic model, medium felt, pair.. 5.75

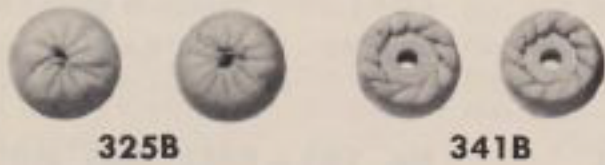

- No. 325B—Balls only for #325 model, per pair } \$2.75
- No. 341B—Balls only for #341 model, per pair }

BASS DRUM BEATERS

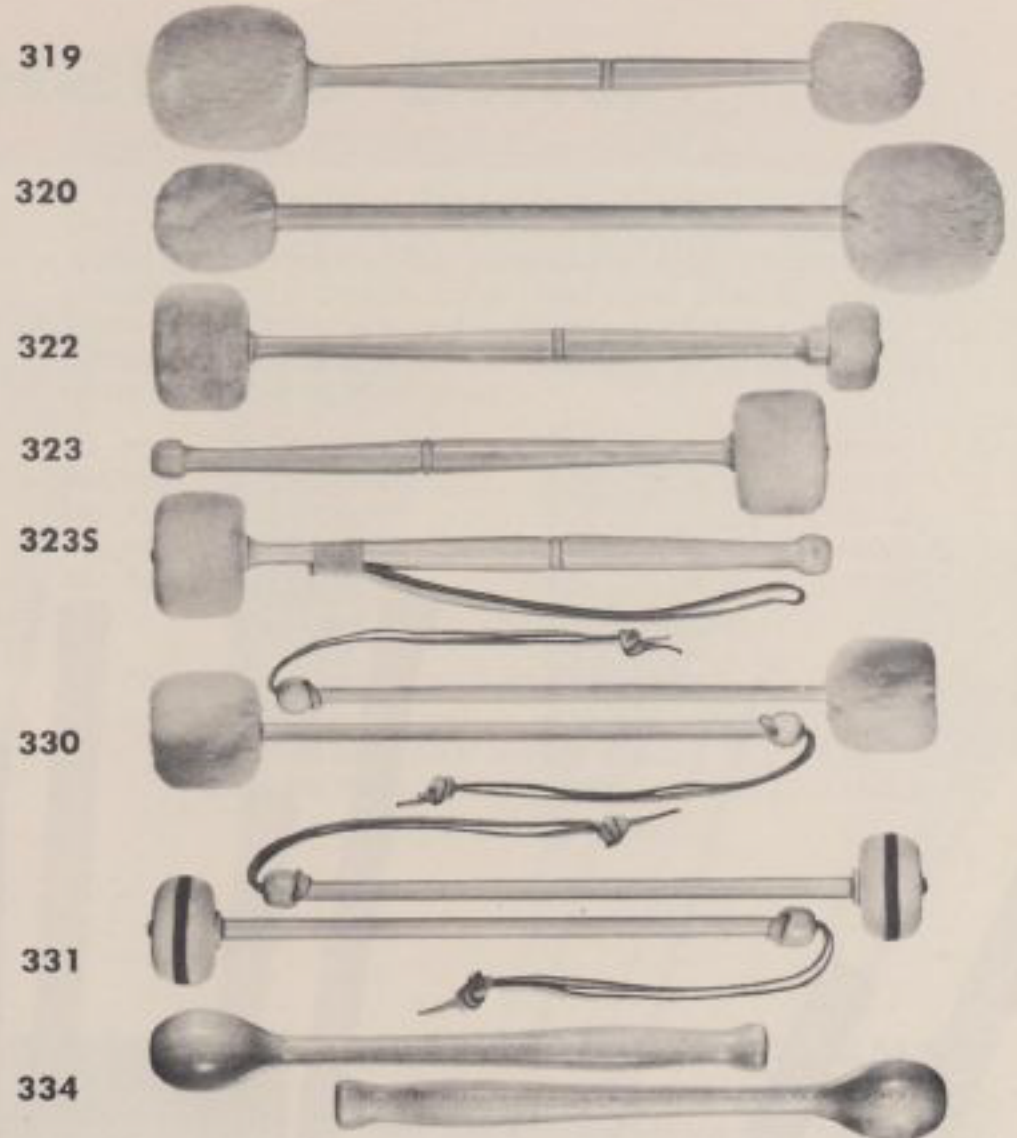

TENOR STICKS

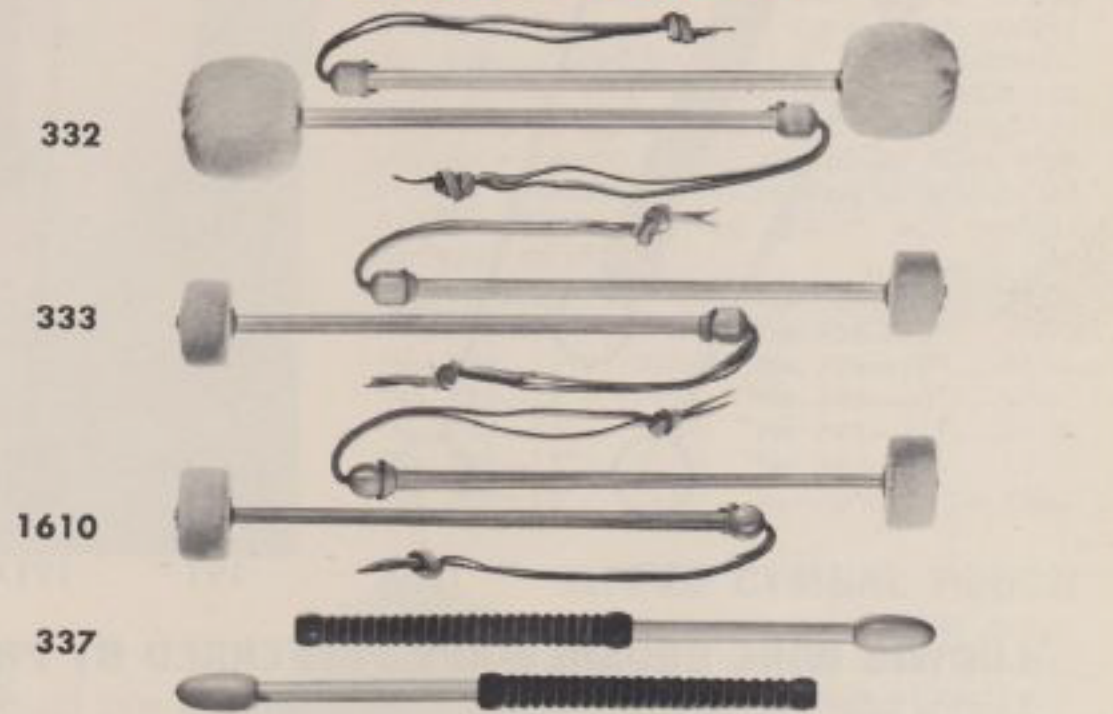

- No. 335—Thongs only, per pair.....90c

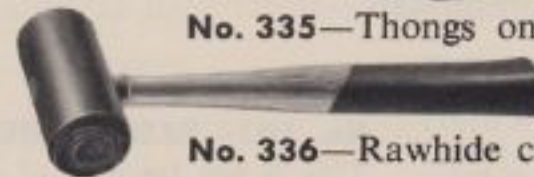

- No. 336—Rawhide chime mallet, each... \$5.50

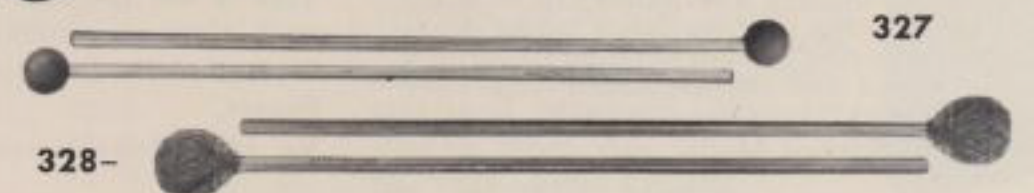

- No. 327—Rubber marimba mallets, specify soft, medium, or hard, per pair.....\$2.50
- No. 328—Yarn wound marimba mallets, specify small, medium, or large, per pair..... 4.75

LUDWIG

Swish

WIRE BRUSHES



LUDWIG WIRE BRUSHES ARE PREFERRED BY PROFESSIONALS!

Ludwig offers the largest and most complete line of wire brushes available today. This wide selection provides each player with *THE* brush for his particular needs.

Each model has been carefully designed for correct balance and is constructed of only the finest materials. Wires *will not* drop out and are machine-fanned to the popular width. Follow the top professionals—select your favorite model from the quality line of Ludwig brushes.

No. 190—RED RIBBED MODEL

Handle is molded approximately to same diameter as the average dance model drum stick. Deep ribs prevent slipping or turning while in use and provide added weight for cymbal work.

No. 190—Ribbed Model, pair..... **\$2.00**

No. 190A—WHITE RUBBER MODEL

Here's the most popular of all! Small, smooth white rubber handle especially designed for circular press rolls and small combo work.

No. 190A—White Rubber Model, pair..... **\$1.80**

No. 191—RED GROOVED MODEL

This is the favorite of drum star Buddy Rich. Grooves prevent turning while in use. Slim handle fits comfortably between fingers.

No. 191—Red Grooved Model, pair.. **\$1.80**

No. 191A—BALL END GROOVED MODEL

Grooved red rubber handle prevents turning while in use. Ball end is designed for cymbal and tom tom use.

No. 191A—Ball End Grooved Model pair..... **\$1.80**

No. 195—WHITE PLASTIC MODEL

The new white plastic model provides a sure-grip, slim handle designed for solid rim shot work.

No. 195—White Plastic Model, pair.... **\$2.00**

No. 192—MOLDED RED RUBBER MODEL

A fine performing model with molded form-fitting rubber handle that will not slip in use. Live rubber handle is ideal for cymbal work.

No. 192—Molded Red Rubber Model, pair..... **\$2.00**

No. 193—BALL END MOLDED MODEL

Molded red rubber handle with ball end for cymbal and tom tom use. Thick flange at end provides solid sock beats.

No. 193—Ball End Molded Model, pair..... **\$2.00**

LUDWIG CYMBALS AND GONGS



IMPORTED SYMPHONIC GONGS

These fine imported gongs are hammered and tempered from the very finest metals with loving care and old-world craftsmanship. They possess the deep, mysterious, resonant and sombre tones that you almost "feel" before you hear. The musical effect of these quality gongs is incomparable—no musical organization is quite complete without one!

No. 754—24" Diameter.....	\$ 90.00
No. 755—26" Diameter.....	110.00
No. 756—28" Diameter.....	140.00
No. 757—30" Diameter.....	180.00
No. 758—32" Diameter.....	230.00

Prices for larger sizes upon request.

No. 761—Ludwig gong stand, chrome plated. . . .	\$25.00
No. 326—Ludwig gong mallet, properly weighted and covered with lamb's wool, chrome plated steel handle.....	\$10.00

Federal excise tax extra.

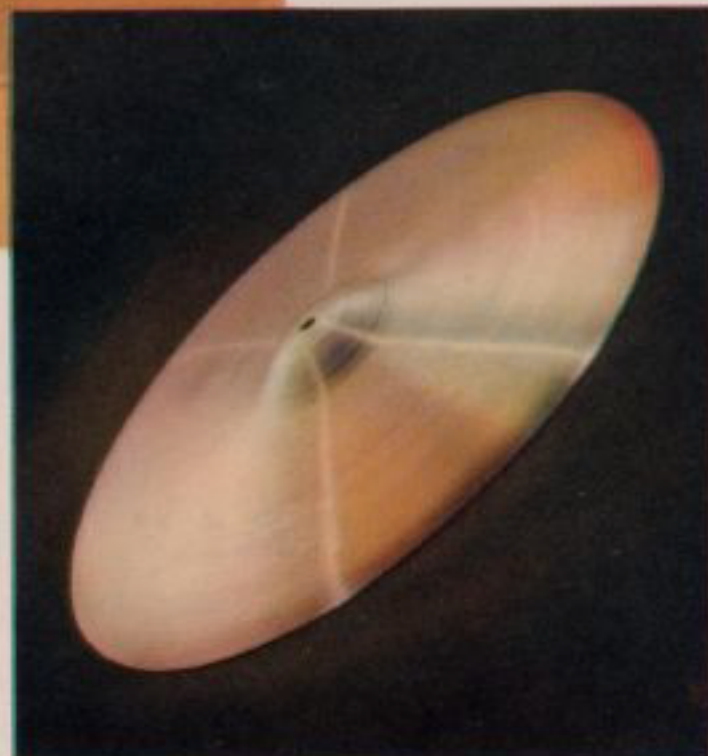

AVEDIS ZILDJIAN CYMBALS

Avedis Zildjian cymbals are world renown for their fine craftsmanship and tone quality. Hi hat cymbals are matched at the Zildjian factory and are from 10" to 15" in diameter. Crash cymbals are usually thin and up to 16" in diameter. Ride or Bounce are medium weight and are supplied from 16" to 22" in diameter.

Marching and concert band cymbals are matched in pairs with marching cymbals usually a heavy weight in smaller sizes with concert cymbals a medium weight in sizes up to 20". When ordering, specify size, weight and type of use.

*No. 730—10" ..	\$15.00	*No. 737—17" ..	37.00
*No. 731—11" ..	17.00	*No. 738—18" ..	40.00
*No. 732—12" ..	20.00	*No. 739—19" ..	45.00
*No. 733—13" ..	23.00	*No. 740—20" ..	50.00
*No. 734—14" ..	27.00	*No. 741—21" ..	55.00
*No. 735—15" ..	30.00	*No. 742—22" ..	60.00
*No. 736—16" ..	33.00		

Federal Excise Tax Extra



IMPORTED LUDWIG CYMBALS

These fine imported cymbals bear the Ludwig stamp of approval for excellent tone, resonance and response. They are carefully fashioned by European craftsmen to produce a high-quality professional tone. They are available in a full range of sizes, weights, and types from 10" thin through 22" medium ride or heavy for concert. Specify weight and use desired when ordering—thin, medium or heavy for concert and parade.

No. 210—10" Ludwig Cymbal... \$10.00	No. 217—17" Ludwig Cymbal... 27.50
No. 211—11" Ludwig Cymbal... 11.25	No. 218—18" Ludwig Cymbal... 30.00
No. 212—12" Ludwig Cymbal... 13.50	No. 219—19" Ludwig Cymbal... 32.50
No. 213—13" Ludwig Cymbal... 16.50	No. 220—20" Ludwig Cymbal... 35.00
No. 214—14" Ludwig Cymbal... 20.00	No. 221—21" Ludwig Cymbal... 37.50
No. 215—15" Ludwig Cymbal... 22.00	No. 222—22" Ludwig Cymbal... 40.00
No. 216—16" Ludwig Cymbal... 24.50	

Federal excise tax extra.



ZIPPER CYMBAL POUCH

Here is an entirely NEW design in cymbal pouches. Sturdy, leatherette finish attractively stitched with Zipper opening. Completely dust-proof. Convenient to carry on the march.

No. 1387—18" dia. Zipper Leatherette Cymbal Pouch.....	\$15.00
--	---------

FIBER CYMBAL CASE

Here's a new fiber cymbal carrying case to hold all size cymbals up to and including 18" diameters. Ideal for both dance drummers and the concert band. Measures 18" square by 5 1/2" wide.

No. 1388—Fiber cymbal carrying case..	\$9.50
---------------------------------------	--------



LUDWIG'S FAMOUS SPEED KING PEDAL

The Ludwig Speed King pedal is used by more professional drummers than any other make. First designed and produced by Ludwig in 1937, it has seen constant progressive improvements and today stands **FIRST** in the ranks of drum pedals. It's the world's only pedal made with precision die-cast stand, footboard, rocker shaft and heel plate! It is also the **ONLY** pedal with compression springs completely enclosed in twin pedal posts!

Twin ball bearings are completely enclosed with lifetime lubricant. Tension is adjustable for any action required. Arched rocker shaft offers leverage where most needed. New rubber base mat is fitted to the base to prevent skidding. New heavy-duty connecting link will withstand every foot pressure. The Speed King is rugged, tough, easy-working and "tried and approved" in over twenty years of continuous use by America's leading professionals!

No. 201—Speed King pedal.....\$22.00

- Twin Ball Bearings

- Twin Compression Springs

- Steel Unbreakable Toe Clamp

- Fast, Positive Tension Adjustment

- New Non-Skid Rubber Base Mounting

- Exclusive Reversible Heel Plate



No. 201

Exclusive reversible heel plate can be "flipped" in an instant to provide one or two piece footboard!

Springs are made to be compressed—not stretched—and with each stroke of the action, Speed King compression springs get stronger and faster!



RED "UNIVERSAL" SPEEDMASTER

Wm. F. Ludwig invented the first floor toe pedal in 1909 and thereby founded the modern drum manufacturing business. This model is a direct descendent of that first model but with many modern improvements. It's the *only* ball-bearing pedal in its price range. Has solid one-piece unbreakable footboard, fully adjustable spring, and smooth leather connecting strap. Rugged Ludwig construction *plus* precision-balanced design make the "Universal" Speedmaster a dream come true for the modern drummer.

No. 252—Red Universal Speedmaster.....\$15.00



No. 252

- Ball bearing action
- Free-floating strap
- Die-cast stand and rocker
- Complete action adjustment

• Fully reversible

• Ball bearing action

• Free-floating leather strap

• Two-position beater rod

• Die-cast pedal stand and rocker

BLUE "REVERSIBLE" SPEEDMASTER

ENJOY THE FASTEST HAIR-TRIGGER PEDAL ACTION IN THE DRUM WORLD!

Here's the latest in fast, effortless pedal action—the all-new Ludwig Blue "Reversible" Speed Pedal. Designed *by and for* professionals, this versatile pedal has many outstanding features recommended by big-name artists! Precision-balanced pedal operates in *two* positions—just reverse plunger and beater rod for "up-stroke" playing. Flexible leather strap permits smooth "free-floating" beat in every tempo . . . reduces leg fatigue to absolute minimum. Ruggedly built—no links to stick, snap, or squeak. Fully adjustable to every foot "feel."

Ludwig's sensational new Blue "Reversible" is the world's best pedal buy!

No. 205 —Blue Reversible Speed Pedal **\$18.00**



No. 205

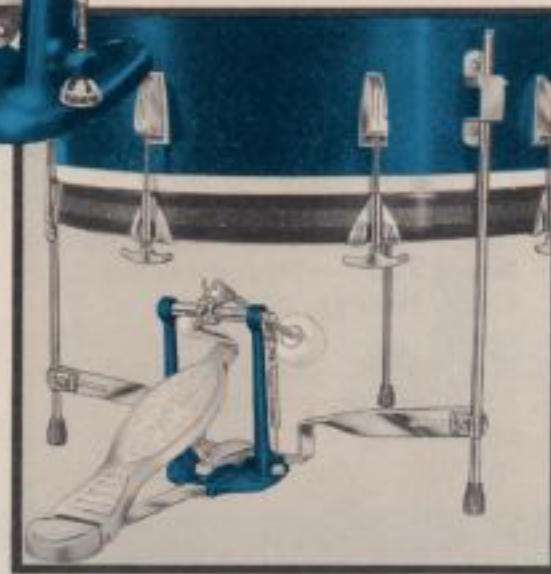

This model is fully reversible for up-beat playing either on Cocktail Lounge drums or your floor tom toms. The pedal bar is required and is an extra \$4.00. Flexibility of leather strap permits easy reversal.



No. 206

THE JUNIOR PEDAL

Here is the latest in the Ludwig line of illustrious pedals. The new Junior model has fast and smooth action (bushings of nylon) and complete spring adjustment. One-piece cast footboard properly mounted for maximum leverage assures fast, immediate pedal response. It is ruggedly constructed to provide maximum life and satisfaction.

No. 206—Ludwig Junior Pedal **\$12.00**

THE "UP BEAT" PEDAL

features:

- Ball bearing action
- Adjustable strap
- One-piece footboard
- Complete height adjustment



No. 208

This unique shell mounted pedal is designed for use with standup Cocktail Lounge drums or floor tom toms. The smooth ball bearing action and one-piece footboard provide quick response and smooth action. Adjustable leather strap accommodates any height of tom tom legs. Comes complete with pedal leg, mounting brackets and directions.

No. 208—Shell mount "Up Beat" pedal, complete **\$18.00**

THE LUDWIG LINE OF QUALITY HOLDERS AND

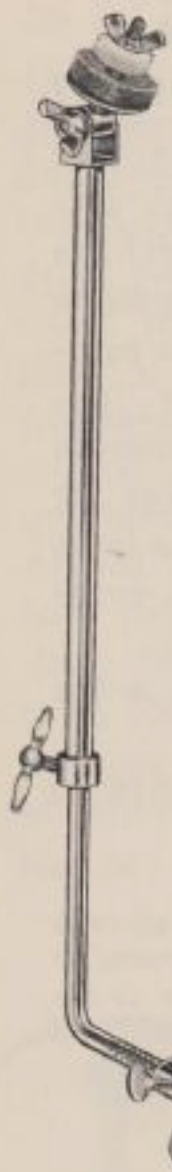

SHELL MOUNT CYMBAL HOLDER

A new and improved tilting cymbal holder. Complete height and angle adjustment. Shell mount flush fitting bracket with double locking action assures rigid cymbal mounting.

- No. 1372 —Shell Mount Cym. Holder, complete, nickel..... \$6.00
- No. 1372C—Shell Mount Cym. Holder, complete, chrome..... 7.00

No. 1372 Complete

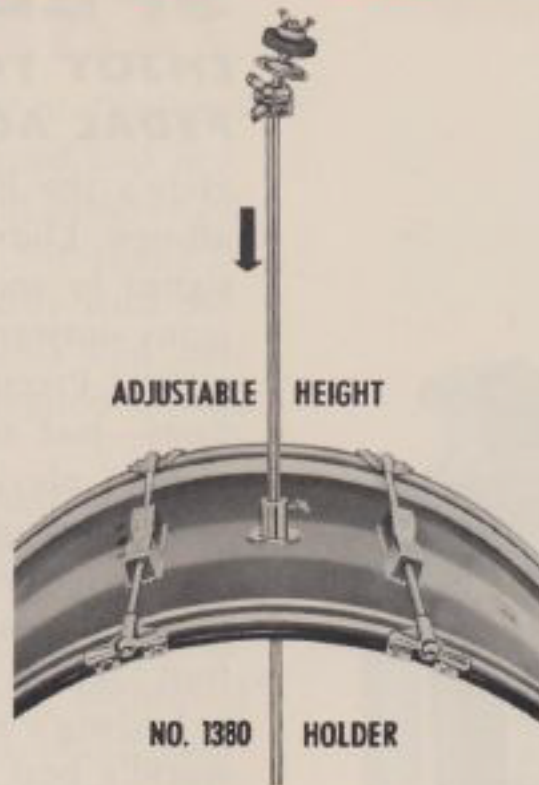

DISAPPEARING CYMBAL HOLDER

The modern shell mount disappearing cymbal holder provides fast, effortless cymbal setup. Holder simply disappears into bass drum when not in use. Built in tilter offers cymbal angle adjustment.

- No. 1380 —Disappearing Cym. Holder, complete, nickel..... \$4.00
- No. 1380C—Disappearing Cym. Holder, complete, chrome..... 5.00



HOOP MOUNT CYMBAL HOLDER

A completely adjustable hoop mount holder with built in cymbal tilter. Holder can be mounted anywhere on your bass drum hoop. New design offers rigid cymbal mounting.

- No. 1370 —Hoop Mount Cym. Holder, complete, nickel..... \$6.00
- No. 1370C—Hoop Mount Cym. Holder, complete, chrome..... 7.00
- No. 1371 —Sleeve only with built in tilter, nickel..... 3.50
- No. 1371C—Sleeve only with built in tilter, chrome..... 4.00

No. 1371 Sleeve Only

No. 1370 Complete



LUDWIG CYMBAL and TOM TOM

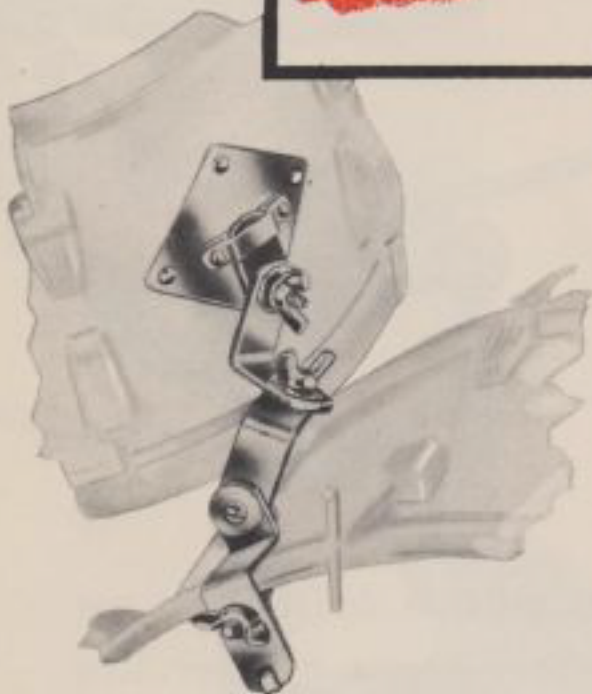

"CLIPPER" HOOP MOUNT TOM TOM HOLDER

A solid hoop mount tom tom holder offering complete angle adjustment. Clip mounting on tom tom provides *ONE SECOND* set up. Constructed of top grade steel polished and plated to a gleaming lustre.

- No. 45N —Hoop Mount Tom Tom Holder, nickel..... \$6.00
- No. 45NC—Hoop Mount Tom Tom Holder, chrome..... 8.00

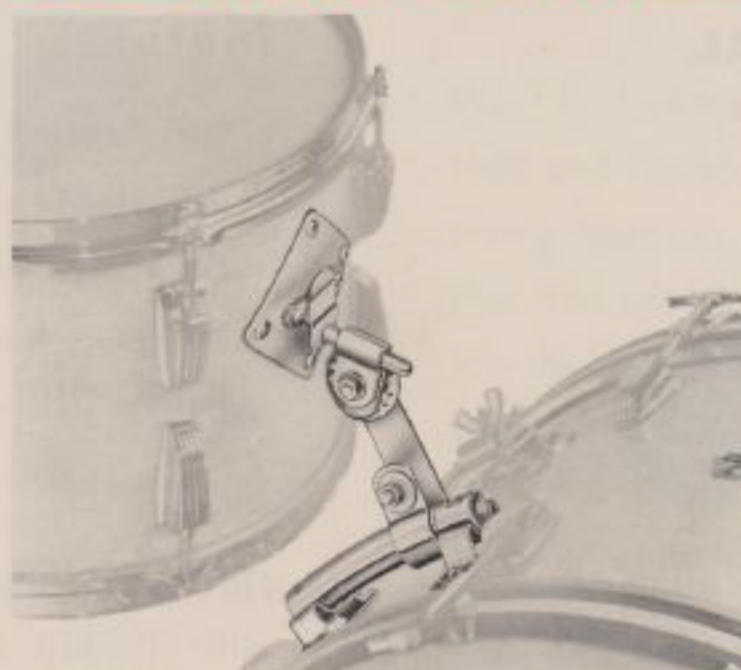

"CLIPPER" SHELL MOUNT TOM TOM HOLDER

The NEW CLIPPER shell mount holder is the most solid tom tom mounting on the market. Clip plate on tom tom provides *ONE SECOND* set up. Pre-set adjustment assures accurate playing position.

- No. 782 —Shell Mount Tom Tom Holder, nickel..... \$12.00
- No. 782C—Shell Mount Tom Tom Holder, chrome..... 14.00

RETRACTING DOUBLE TOM TOM HOLDER

The NEW retracting double tom tom holder is another Ludwig FIRST in modern outfit design. It offers a solid double mounting with complete height and angle adjustment. Center bass drum mounting provides ideal playing position.

- No. 781 —Retracting Tom Tom Holder, nickel.. \$18.00
- No. 781C—Retracting Tom Tom Holder, chrome. 20.00

ACCESSORIES . . .



CYMBAL TILTER

The Cymbal Tilter securely holds cymbal in any desired position. Fits on top of standard cymbal rod. Available in nickel plate only.

No. 1395—Cymbal Tilter.....\$1.75



ALL RUBBER CYMBAL SEAT

A molded rubber cymbal seat that fits on the end of any standard cymbal rod. Just snap holder on cymbal and mount on rod. Eliminates cymbal contact with metal rod.

No. 2493—All Rubber Cymbal Seat.....\$0.35



No. 1301

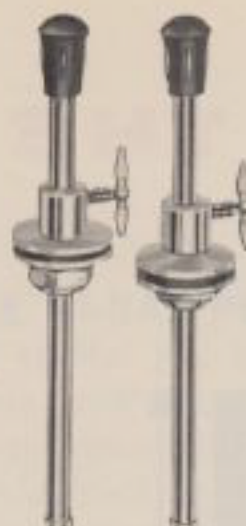

No. 1303

RETRACTING SPURS

Retracting spurs are mounted on shell and disappear into bass drum when not in use. Provides fast set up.

No. 1303 —Retracting Spurs, pair, nickel.....\$4.00

No. 1303C—Retracting Spurs, pair, chrome..... 5.00

GIANT SPURS

Ludwig Giant Spurs mount on bass drum counter hoop. Will fit all size bass drums. Available in nickel only.

No. 1301—Giant Spurs, pair.....\$3.00

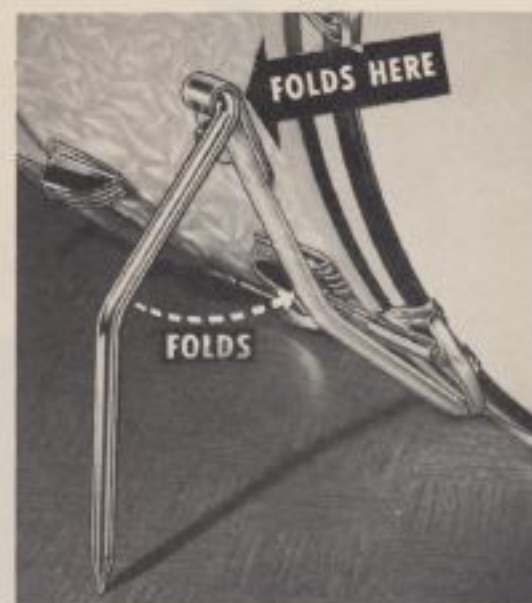

SHELL MOUNT FOLDING SPURS

Shell mount folding spurs are standard on all Ludwig outfits. They provide fast, accurate setup and hold bass drum solidly in position. Flush folding allows easy packing in case.

No. 1305 —Folding Spurs, pair, nickel.....\$4.50

No. 1305C—Folding Spurs, pair, chrome..... 6.75

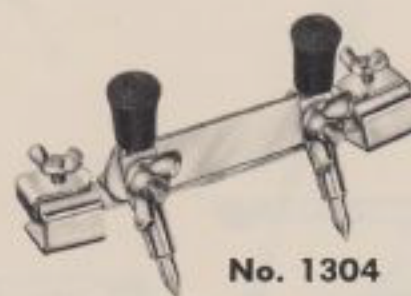

No. 1304

BASS DRUM ANCHOR

The Anchor prevents bass drum from "creeping" when being played. Reversible tips offer choice of rubber or steel points. Available in nickel only.

No. 1304—Bass Drum Anchor.....\$4.50

HOLDERS

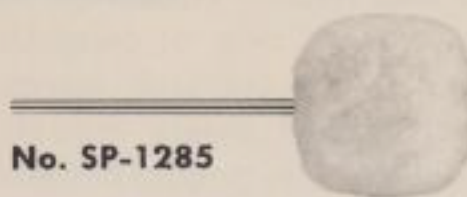
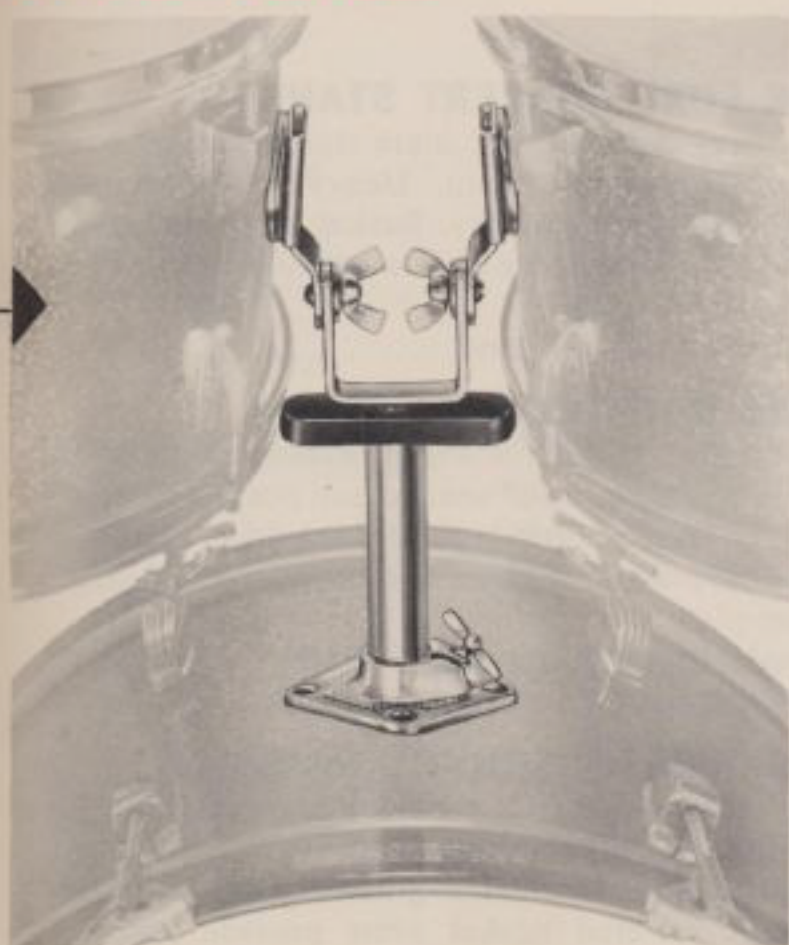

No. SP-1285

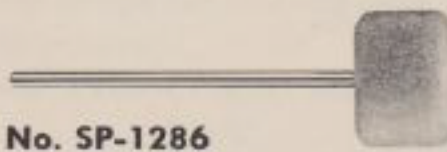

No. SP-1286

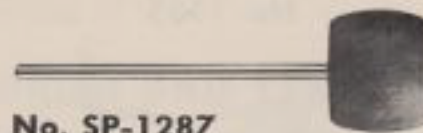

No. SP-1287

BASS DRUM PEDAL BEATERS

Ludwig offers three types of bass drum pedal beater balls: lamb's wool, hard felt and wood.

No. SP-1285—Lamb's Wool Pedal Beater.....\$2.50

No. SP-1286—Hard Felt Pedal Beater..... 2.50

No. SP-1287—Wood Pedal Beater..... 2.50



No. 136



No. 134

BASS DRUM MUFFLERS

Ludwig bass drum mufflers are available in two types; the Standard Pressure model and the Adjustable Pressure model. Angle adjustment arm enables muffler to be placed in different positions on the head.

No. 136—Adjustable Bass Drum Muffler.....\$4.50

No. 134—Pressure Bass Drum Muffler..... 3.75

THE LUDWIG LINE OF FLAT



Formed rubber cymbal seat improves stability of cymbals.

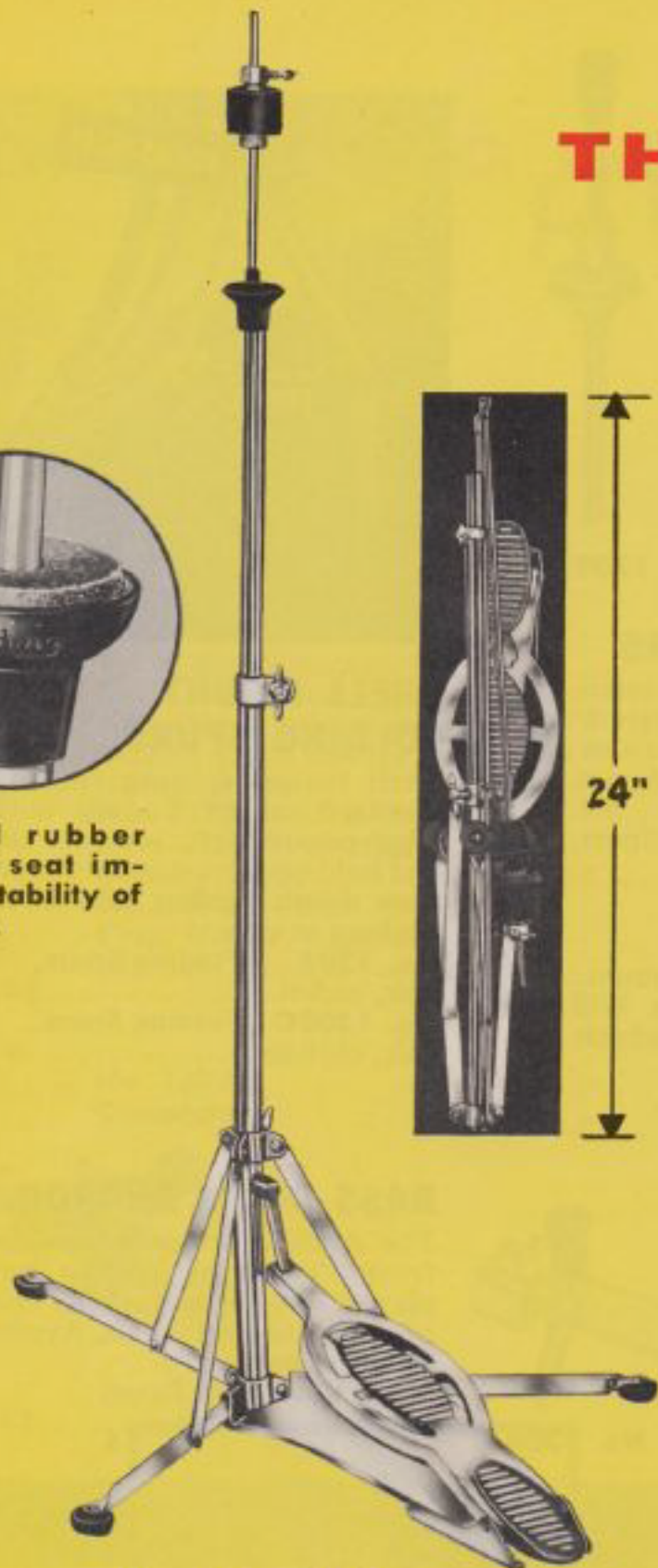

No. 1121—Hi-Hat



No. 1400
Cymbal Stand

- **Modern Styling**
- **Quality Construction**
- **All Chrome Plated**

The Ludwig line of FLAT BASE stands offers the greatest value available to the drum world. Their modern styling provides a convenient stand arrangement with extra leg room behind the outfit. Top quality all-steel construction is virtually unbreakable. Each stand is finished in glistening chrome plate for years of satisfactory service. FLAT BASE design allows stands to fold compactly for easy packing. This new and improved Hi-Hat pedal offers a smooth, sensitive action for today's most discriminating drummers. Compare the design, construction and price of Ludwig's FLAT BASE line with leading competitive makes and see why more top drummers choose Ludwig.

- No. 1363—Flat Base Snare Stand, chrome..... \$ 9.95
- No. 1400—Flat Base Cymbal Stand, chrome..... 9.95
- No. 1121—Modified Hi-Hat Pedal, chrome..... 19.50



No. 1354



No. 1358



No. 1355

DE LUXE CONCERT STAND

A top quality, heavy duty concert snare stand offering complete height and angle adjustment. Heavy cast iron base provides added weight and stability. Basket arms and extension rod are chrome plated, base and lower tube are finished in black enamel.

- No. 1354—De Luxe Concert Stand..... \$13.50

THE BUCK ROGERS STAND

A popular heavy duty stand for the professional drummer who requires absolute stability of snare drum position. Expansion basket arms adjust to clamp around snare drum. Provides complete height and angle adjustment. Available in either chrome or nickel plate.

- No. 1358 —Buck Rogers Snare Stand, nickel..... \$19.00
- No. 1358C—Buck Rogers Snare Stand, chrome..... 21.00

MICROMATIC SCHOOL STAND

An ideal school stand featuring wide-angle tripod base for maximum stability. Complete height and angle adjustment. Solid steel construction is finished in glistening chrome plate. New black plastic covered basket arms provide years of lasting beauty.

- No. 1355—School Snare Stand..... \$9.95

BASE STANDS

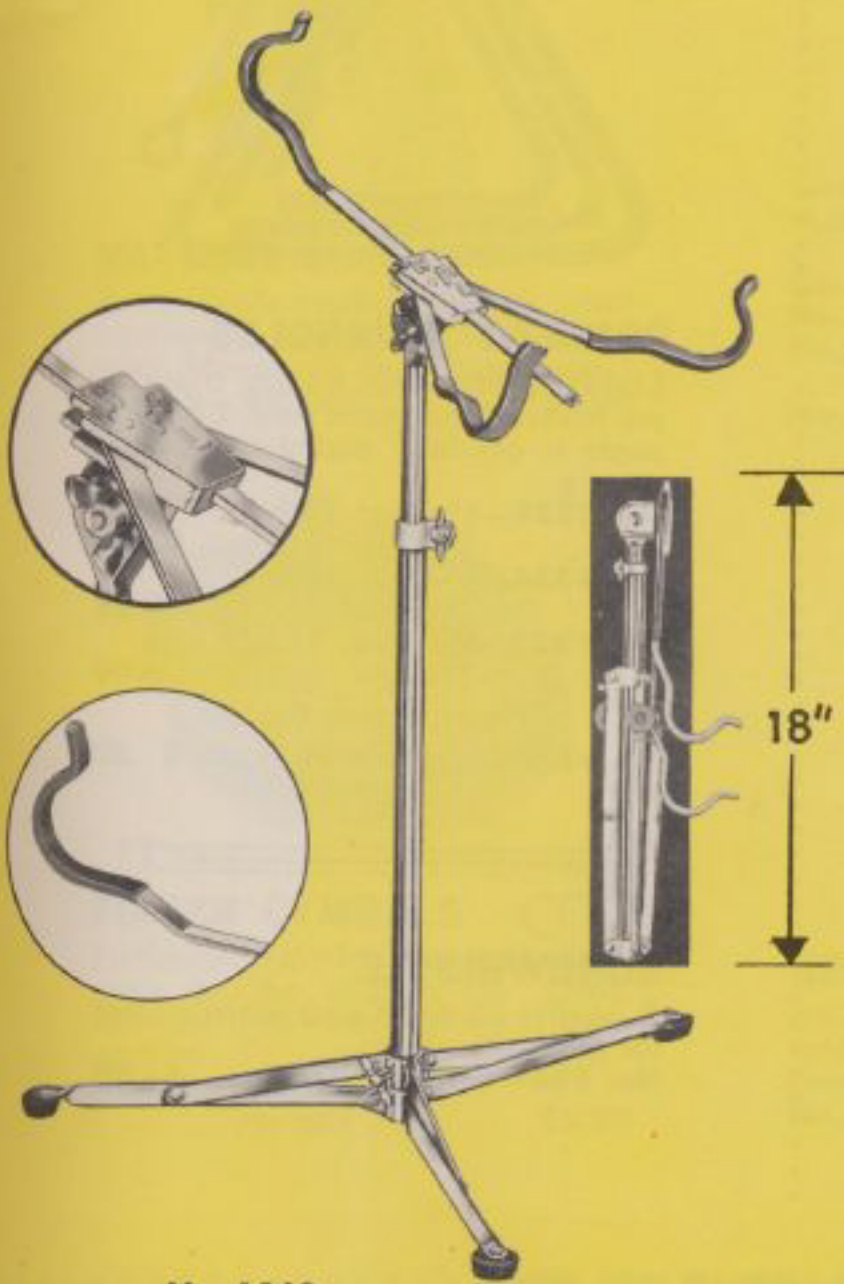

No. 1363
Snare Stand



No. 1357

JUNIOR DRUM STAND

A light weight, junior stand designed for the beginning drummer. Has complete height and angle adjustment. Folds for easy packing in drum case. Available in nickel plate only.

No. 1357—Junior Drum Stand. **\$6.75**

MIRACLE HI-HAT PEDAL

The "Miracle" Hi-Hat has long been a standard favorite with the professional trade. Light weight construction and folding features provide packing ease. Friction free pedal action offers fast effortless response. Available in either chrome or nickel plate.

No. 1122 —Miracle Hi-Hat Pedal, nickel..... **\$15.00**

No. 1122C—Miracle Hi-Hat Pedal, chrome..... **18.00**



No. 790

DE LUXE CONCERT BASS DRUM STAND

A top quality concert bass drum stand designed to offer years of dependable service. Supplied with a glistening triple chrome plated finish, heavy rubber covered support rails and special mounting straps for holding bass drum rigidly in position.

No. 790—Concert Bass Drum Stand..... **\$18.00**

DRUM AND TYMPANI STOOL

Here is the finest drummers and tympanists' stool available. Rigid, heavy duty steel construction guarantees absolute dependability. Height adjustment is provided by locking bolt and wing nut mounted through adjustment tube. *Positively will not slip!* Wide-angle tripod legs fold for easy packing. Seat is of red leatherette, padded for extra comfort.

No. 1026—Drum and Tympani Stool..... **\$18.00**

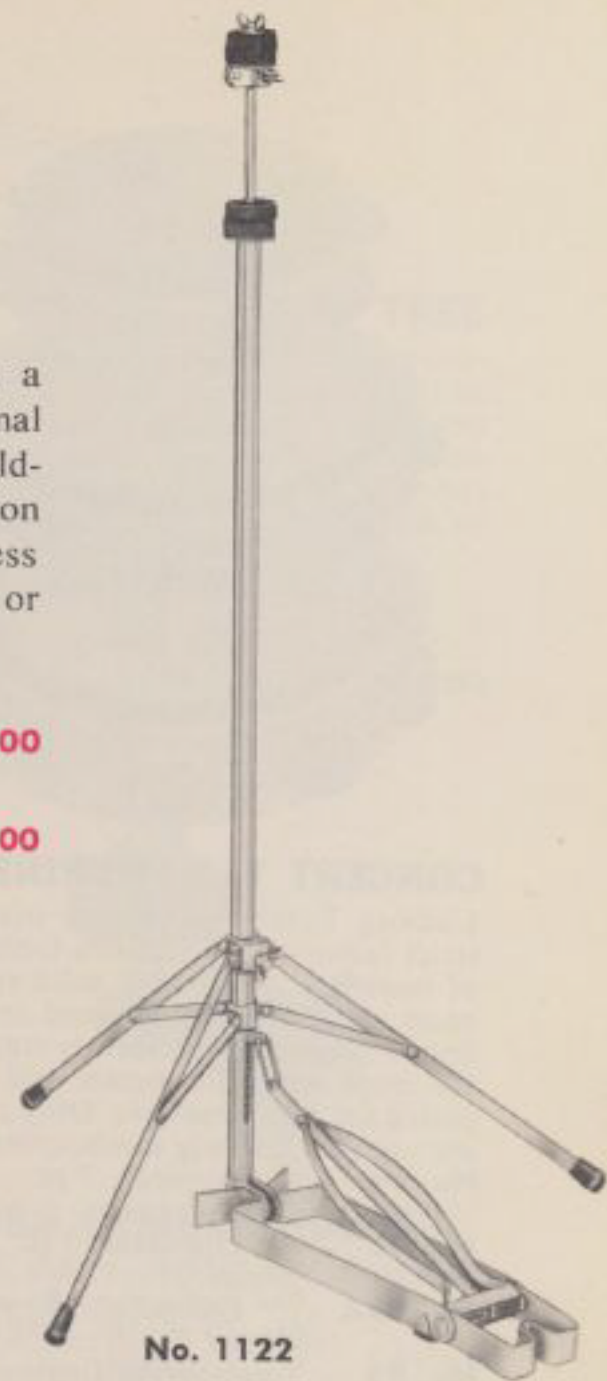

No. 1122



No. 1026



CONCERT TAMBOURINES

Ludwig Tambourines are made under strict factory specifications from the finest of materials. Shell is of solid rock maple, hand sanded and lacquered in a natural finish. Jingles are uniformly stamped from the most resonant metals and are nickel plated for maximum life. Only select heads are used on Ludwig tambourines.

- No. 94 —8" Diameter, 7 pr. jingles.....\$4.50
- No. 95 —10" Diameter, 9 pr. jingles..... 5.50
- No. 95A—10" Diameter, 18 pr. jingles..... 7.50
- No. 93 —Tambourine Jingle only each10



WRIST BELLS

Four resonant sleigh bells are securely mounted on a wrist strap providing accurate rhythmic manipulation.

- No. 96—Wrist Bells, each \$.80



SLEIGH BELLS

A set of 25 sleigh bells mounted on a handle. Ideal for concert use in many descriptive numbers.

- No. 97—Sleigh Bells....\$10.00



SLAPSTICK

Top quality hard wood is activated by strong spring producing desired "whip" effect.

- No. 74—Slapstick.....\$4.50

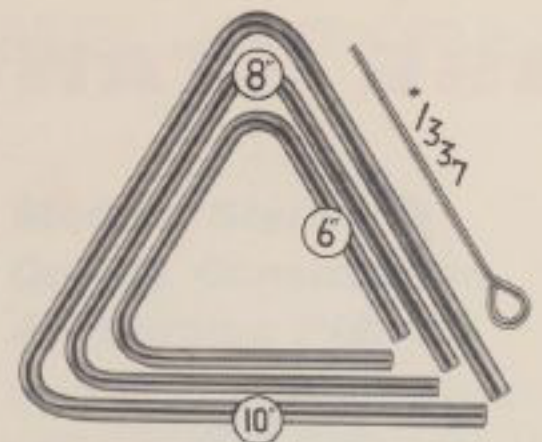

CONCERT TRIANGLES

Ludwig professional quality triangles are made of top grade steel. Each triangle is carefully plated to prevent rusting.

- No. 1333—6" Clear Tone Triangle.....\$3.00
- No. 1334—8" Clear Tone Triangle..... .3.25
- No. 1332—10" Clear Tone Triangle..... 4.00

Prices Include Beater

- No. 1337—Steel triangle beater \$.80

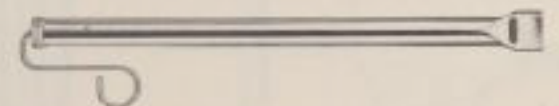

SONGWHISTLE

A quality all-metal slide whistle ideal for glissando effects.

- No. 536—Songwhistle.....\$4.00

Ludwig

ACCESSORIES.....



No. 91 No. 92 No. 90

CASTANETS

Nothing conveys the impression of a crisp Spanish dance like these fine, professional style castanets. Plastic clappers are mounted on hard wood handles providing the maximum resonance. Can be either hand or finger controlled.

- No. 90—Hand castanets, per set of four clappers.....\$2.00
- No. 91—Single pair castanets on handle..... 2.50
- No. 92—Double pair castanets on handle..... 3.25



TUNABLE TONE BLOCK

Made of durable black ebonite and tunable by moving pins together for higher tones and apart for lower.

- No. 777—Tunable tone block.....\$2.50
- No. 773—Single block holder..... 1.60



GENUINE WOOD BLOCKS

Carved from select hard wood to provide clear, resonant tone. Available in two sizes.

- No. 774—Large wood block.....\$2.50
- No. 775—Small wood block..... 2.25



TRIANGLE CLIP-HOLDER

The clip-holder fits all music stands and is equipped with gut cord to enhance resonance of triangle.

- No. 1336—Triangle clip-holder \$1.50



BIRDWHISTLE

An all-metal bird call imitation. For proper effect fill half full with water.

- No. 537—Bird-whistle...\$2.50

SIREN WHISTLE

This new all-metal whistle is used for Wind Whistle, Cyclone and Siren Whistle effects.

- No. 539—Siren Whistle...\$4.00





RATCHET

A top grade ratchet made of select hardwoods with nickel plated metal sides. Mounts on bass drum hoop.
No. 75—Ratchet..... **\$6.00**

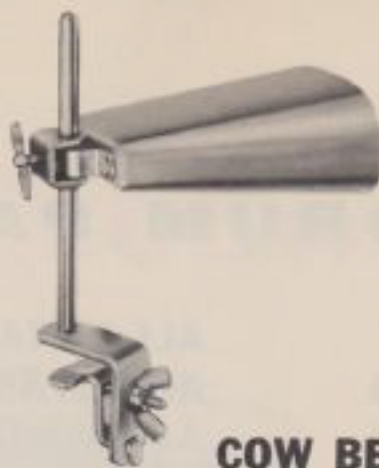

COW BELLS

Ludwig "clear tone" cow bells provide authentic tone for today's modern Latin and discriptive numbers.
No. 128 —4" Cow Bell.... **\$2.00**
No. 129 —5" Cow Bell **2.25**
No. 133 —Cow Bell Holder..... **1.75**
No. P1635—"U" Clamp for Holder..... **.50**

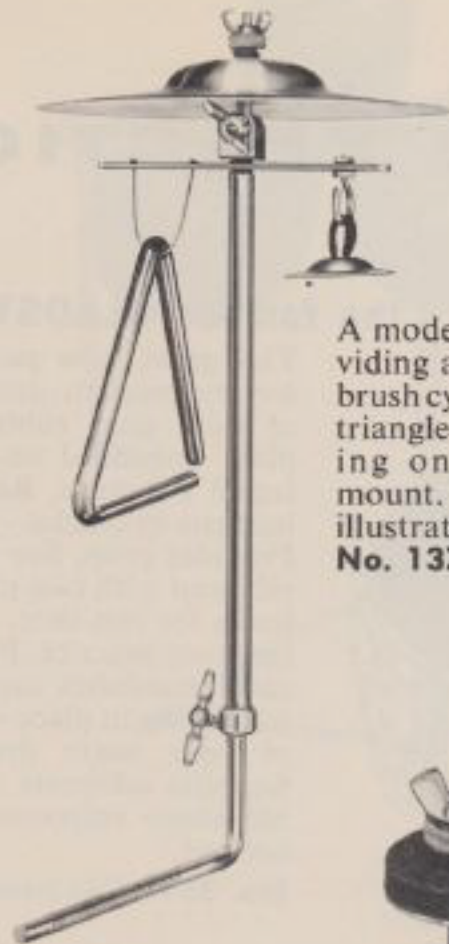

TRAP TREE

A modern jazz innovation providing an ideal arrangement of brush cymbal, finger cymbal and triangle. Designed for mounting on bass drum cymbal mount. Supplied complete as illustrated.
No. 1375—Trap Tree, complete, chrome only..... **\$10.00**



FINGER CYMBALS

Professional quality Finger Cymbals made by the Zildjian Co. Clear, resonant tone blends with any composition.
No. 85—Finger Cymbals, per pair **\$5.00**



BELL-BLOCK HOLDER

An ideal combination cow bell—wood block holder for mounting on bass drum hoop or trap table.
No. 1323—Bell-Block Holder..... **\$2.25**



BRUSH CYMBAL HOLDER

Hoop clamp holder for brush or special effect cymbal.
No. 1379—Brush Cymbal Holder..... **\$1.25**



LAMB'S WOOL CYMBAL HOLDER

A Deluxe lamb's wool cymbal pad with leather thongs. Easy on the hand while providing perfect cymbal action.
No. 1365—Cymbal Holders, pair..... **\$6.00**
No. 1366—Leather Thongs Only, each..... **.50**



WOOD HANDLE CYMBAL HOLDERS

A solid, hard wood handle that bolts to the cymbal. Plastic loop provides a sure grip.
No. 358—Wood Handle Cymbal Holder, pair..... **\$2.25**

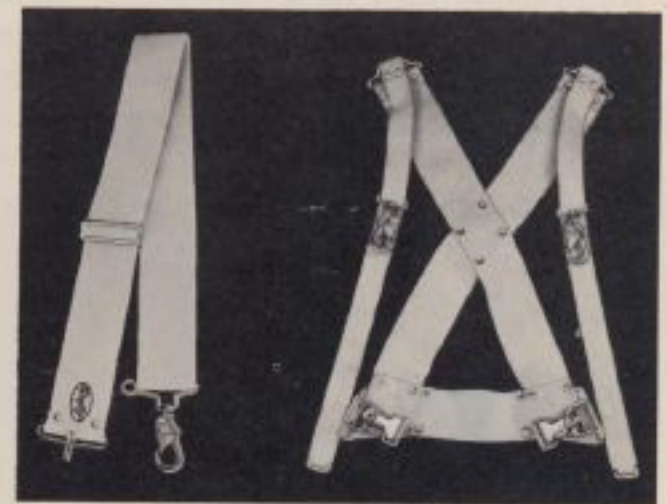

No. 352

No. 350

DRUM SLINGS

Quality drum slings designed for maximum carrying ease and control of the instrument. New bass drum sling provides extra freedom of arm movement. Available in WHITE only.
No. 350—Bass Drum Sling, white only..... **\$4.00**
No. 352—Snare Drum Sling, white only..... **2.00**



BASS DRUM CYMBAL HOLDER

Holds cymbal securely on bass drum for combination bass drum and cymbal playing. Attaches to bass drum hoop.
No. 357—Bass Drum Cymbal Holder... **\$4.50**



PLASTIC CYMBAL HOLDERS

Leather thongs with plastic pads provide the ideal holder for good cymbal response and tone.
No. 1367—Plastic Cymbal Holder, pair..... **\$3.00**

LUDWIG'S PRACTICE DRUM PADS

Now available . . . the famous GLADSTONE PAD



This great, new pad is designed for the modern drummer. Made of pure gum rubber with steel plate imbedded to make an integral structure. Resilient, never hardens or cracks—never softens. Provides crisp, live natural drum rebound with two playing surface levels for rim shot, timbales, and tom tom practice. Patented structure establishes vacuum, holding pad firmly in place on batter head of your snare drum or table. Supplies adequate volume, audible snare response and perfect control.

No. 351—Gladstone Pad. \$6.00

ALL-METAL PAD AND ADJUSTABLE STAND

A convenient practice arrangement using the No. 355 pad mounted on height adjustable stand. Pad is easily detachable, stand folds for packing.

No. 2010—No. 355 Pad and Stand, complete \$10.00

No. 1359—Stand only for No. 355 Pad..... 6.00



ALL-METAL PRACTICE PAD

This popular pad features solid one-piece aluminum construction with thick, live gum rubber set into playing surface. New suction cup feet provide solid anchor to any surface.

No. 355—Metal Pad. \$4.50



HEAVY DUTY WOOD PAD

A top quality professional pad constructed of select hard woods with thick, live gum rubber set into playing surface. Provides proper stick rebound for years of satisfied service.

No. 355W—Heavy Duty Pad. \$4.50



ALL-RUBBER PORTO-PAD

A handy pocket size practice pad of molded top grade gum rubber. Ideal for use on head of drum. Easy to carry—convenient to use.

No. 354—Porto Pad. \$2.00



LIGHT DUTY ECONOMY PAD

A quality low priced pad for the beginning drummer. Live rubber playing surface is mounted on solid angle board and base. Lightweight and easy to carry.

No. 356—Light Duty Pad \$2.50

HEAVY DUTY PAD AND ADJUSTABLE STAND

An ideal teaching and practice arrangement using the No. 355W professional pad mounted on sturdy chrome plated stand. Features complete height and angle adjustment.

No. 2011—No. 355W Pad and Stand, complete.... \$10.00

No. 1360—Stand only for No. 355W Pad..... 6.00



LIGHT DUTY PAD AND ADJUSTABLE STAND

An economy pad and stand for the beginning drummer. The light weight, detachable pad and folding stand are easily packed in drum case.

No. 2012—No. 356 Pad and Stand complete... \$6.00

No. 1361—Stand only for No. 356 Pad..... 4.00

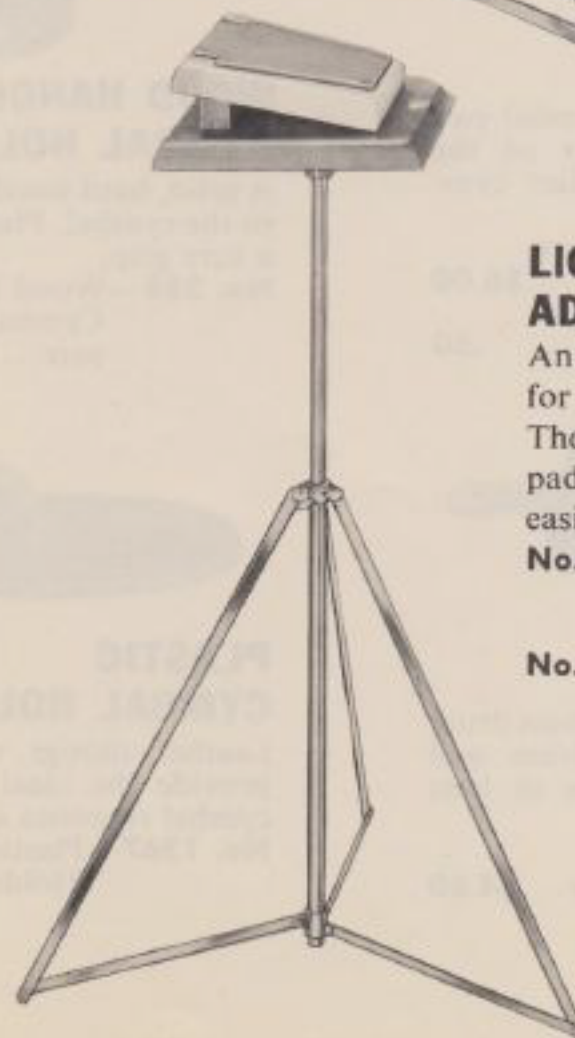

NEW . . . from LUDWIG



CONCERT TOM TOMS

A set of 4 high pitched, single head, tunable tom toms mounted on adjustable stand as illustrated. Ideal for use with the Symphonic Band or in modern percussion ensembles. Sizes 12", 10½", 8" and 6". All four drums nest inside one another for easy packing in a single case. Available in choice of lacquer or pearl finishes.

No. 443—Set of 4 High Tom Toms and Stands, choice of lacquer finish, chrome only **\$145.00**
For pearl finish add: **20.00**



KOREAN TEMPLE BLOCKS AND STAND

A complete set of five hand-carved genuine Korean Temple Blocks finished in bright Chinese red lacquer with gold and black trim. The new Ludwig-designed, heavy-duty, chrome plated stand locates the blocks correctly for use in either standing or sitting positions. Set of five temple blocks or stand may be purchased separately. Supplied complete with mallets.

No. 80 —Set of 5 Temple Blocks with mallets. **\$30.00**
No. 1347—Temple Block Stand, only, chrome plated. . . **15.00**

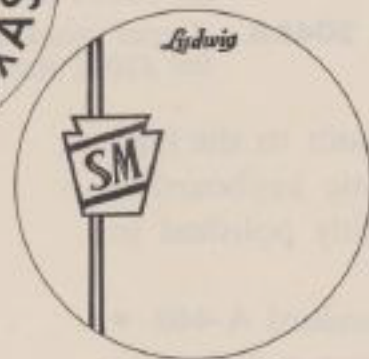

TUNABLE CUBAN BONGOS

Here is the top quality in authentic Cuban Bongos. Thick hardwood shells and heavy heads provide ideal bongo tone. Easily tuned by "Y" bracket mechanism. Hand finished in natural wood beauty.

No. 2356—Tunable Cuban Bongos. **\$35.00**



DRUM HEAD PAINTINGS

No. 1350—Head Lettering, one color—black unless otherwise specified, per letter. **\$.90**

No. 3152—Head Lettering, one color—specify, with black outline, per letter. **1.10**

No. 1351—Shield Monogram, one color—black unless otherwise specified, your initials. **11.00**

CUBAN BONGOS

A real value in the economy line of quality non-tunable bongos. Hand fashioned in natural wood finish. Thick shell and heavy tacked heads combine for authentic bongo tone.

No. 2355—Cuban Bongos. **\$18.00**



CHROMATIC BELL LYRA DE LUXE MODEL

Ludwig's advance design and quality craftsmanship has set new standards of perfection in modern bell lyras. Here is a blend of tone, beauty, strength and ease of playing, offering the lightest weight bell lyra on the market. Ludwig bell lyras are made in our own plant and tuned by our own expert tuners. The De Luxe model is ideal for use on the march as well as in the concert hall.

Specifications: 2 octave, 25 bars A to A • Pitched in C to standard A-440 • Aluminum bars 1 1/4" wide, 3/8" thick • Raised chromatics • One piece aluminum frame • "Two-Tone" keyboard • Felt covered mounting rails • Total weight 14 lbs.

No. 2044—De Luxe Bell Lyra complete with mallets, plumes, carrying strap and mackintosh zipper cover.....**\$110.00**

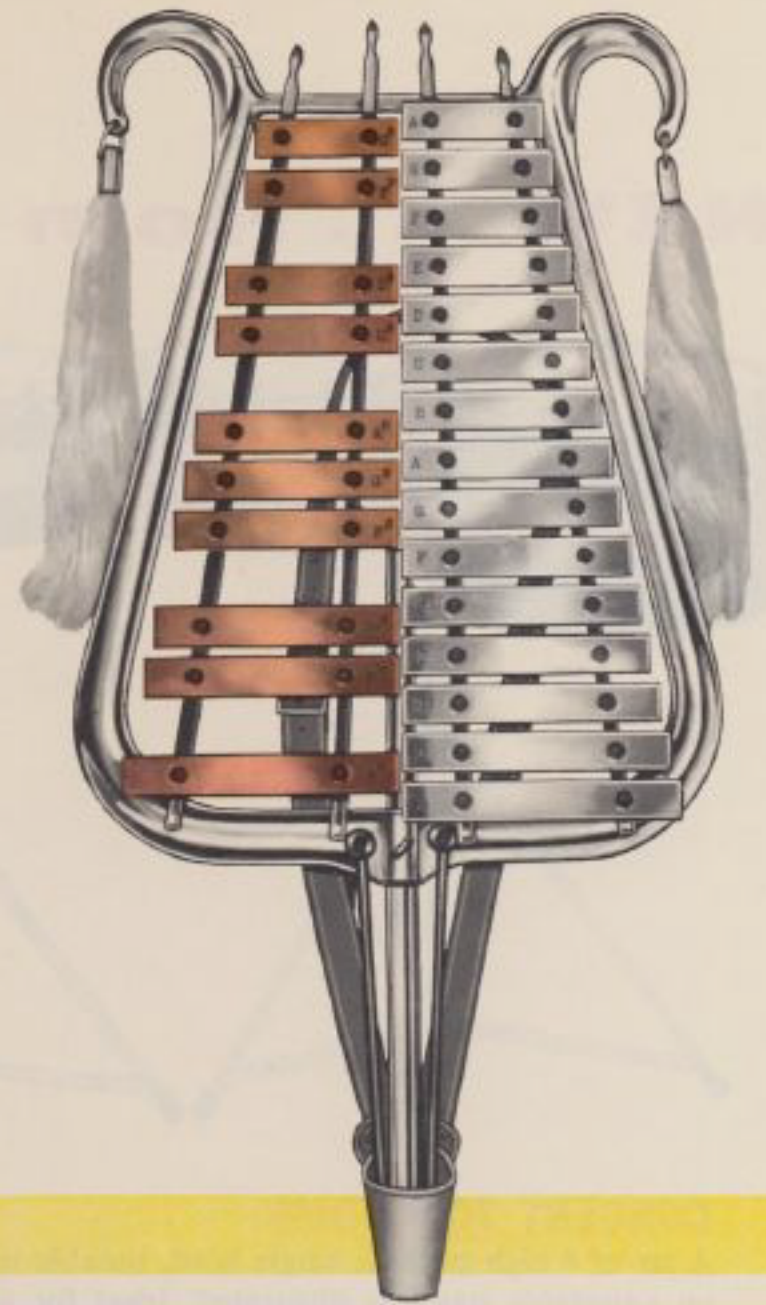

Ludwig bell lyras are supplied complete with 2 bell lyra mallets, 2 plumes, leather carrying strap and a zipper mackintosh cover at no additional cost. These items may be purchased separately if desired.

No. 640 Hard plastic bell lyra mallets, per pair.....**\$3.00**

No. 2047—Leather carrying strap, TAN..... **7.50**

No. 2047W—Leather carrying strap, WHITE..... **9.75**

No. 639—Hair plumes 16" long, white only, per pair.... **5.50**

No. 2048—Zipper mackintosh cover for #2044 model..... **7.50**

No. 2048A—Zipper mackintosh cover for #2041 model..... **7.50**



NEW MARCHING BELL LYRA STANDARD MODEL

The Standard Model marching bell lyra is a quality instrument built to the high standards of the Ludwig tradition. The full two octave chromatic keyboard is expertly tuned to A-440. The aluminum bars and frame are highly polished to a gleaming luster.

Specifications: 2 octave, 25 bars A to A • Pitched in C to standard A-440 • Aluminum bars 1" wide, 3/8" thick, • One piece aluminum frame • Felt covered mounting rails • Total weight 11 lbs.

No. 2041—Standard Bell Lyra complete with mallets, plumes, carrying strap and mackintosh zipper cover.....**\$89.50**

HARD SHELL BELL LYRA CASE

Here's added protection plus an ideal arrangement for using marching bell lyra in concert as orchestra bells. Case features durable leatherette covering, felt lining and quality hardware. Designed for either De Luxe or Standard models.

No. 8000—Hard Shell Bell Lyra case.....**\$20.00**



CONCERT BELL LYRA STAND

A quality concert bell lyra stand made from heavy-gauge stock. Stand is fully adjustable to any position and folds for easy transporting. Heavy nickel plating adds to the beauty and long life.

No. 2049—Concert Bell Lyra stand.....**\$18.00**



Ludwig DRUM

SWING FLAGS

Ludwig's colorful SWING FLAGS will add dramatic appeal to your band or drill team. Flag swinging represents a brand new form of expression. The technique is graceful and the routines are adapted to interesting team work.

LUDWIG LEADS THE WAY IN SWING FLAG DESIGN

Exclusive Ludwig design offers a perfectly balanced swing flag for maximum efficiency. Shaft is of tapered steel tubing, triple chrome plated and polished to a gleaming lustre. Form fitting molded rubber handle provides correct balance, weight and grip for all routines.

The flag itself is made of a special light weight material with unusual strength. Designed for either 32" or 40" shaft. This new sheer material flows easily in the wind and is ideal for high throws.

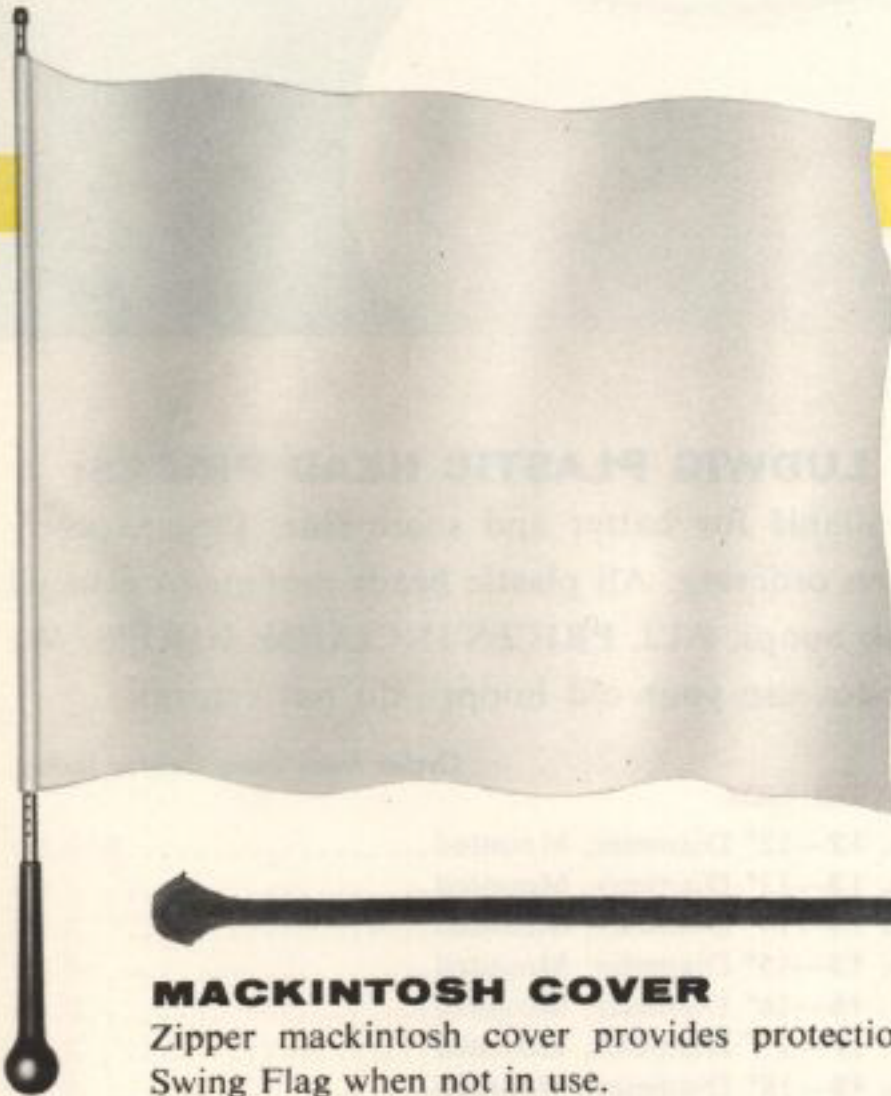

MACKINTOSH COVER

Zipper mackintosh cover provides protection for Swing Flag when not in use.

No. F-45—Zipper cover for Swing Flag.....\$3.75

DRUM MAJOR WHISTLES



STANDARD WHISTLE

Top quality all-metal drum major whistle, extra shrill for clear signals.

No. 118W—All-Metal Whistle..\$2.00



WRIST WHISTLE

Quality all-metal whistle securely mounted on leather wrist strap.

No. 118R—Wrist Whistle..\$3.00

MATCH YOUR SCHOOL COLORS

Ludwig swing flags are supplied in WHITE only, but are easily dyed by the purchaser to any color desired. Any commercial color-fast dye is recommended. Flag is mounted on shaft by patented spring clips that snap into holes in shaft.

- No. F-40 —Swing Flag complete, 40" shaft...\$11.00
- No. F-32 —Swing Flag complete, 32" shaft... 11.00
- No. F-10 —Steel Shaft with handle..... 5.50
Specify length of shaft.
- No. 2801 —Flag clips, set of 2..... .30
- No. 2802 —Flag, white only, with clips..... 4.00
Specify length of shaft.
- No. 2803 —Rubber handle only..... 2.50

DRUM MAJOR SIGNAL BATON

Ludwig SIGNAL BATONS are tops for quality and balance. Tapered shaft is of select hickory, carefully sanded and finished to a high gloss. Ball and ferrule are chrome plated. The braided cord and tassels are available in a variety of colors. Weight 25 oz., Length 44".

Signal baton is regularly enameled in dark blue with gold cord and tassel. Special colors may be ordered at slight additional cost.

- No. 118 —Signal Baton, blue shaft, gold cord..\$18.00
- No. 118S—Signal Baton, special colors, specify. 22.00



LUDWIG "PLAYON" PLASTIC DRUM HEADS



New Ludwig-made plastic drum heads have the feel and response of fine calf skins with none of the weather problems. They are completely impervious to weather changes and will retain snap and crispness throughout all climate changes.

Mounted securely on grooved* metal flanged flesh hoops and ready for instant application to your drum. They are not sold unmounted.

Ludwig "Playon" plastic heads are made in our own plant thus guaranteeing a perfect fit on your Ludwig drum. They hold their setting indefinitely!

Available in four weights: For batter, snare, tympani and tom tom.

PLASTIC TYMPANI HEADS

Tremendous tone and range. Never vary regardless of weather changes!

- No. T-25—25" Mounted Plastic Tympani Head.....\$25.00
- No. T-26—26" Mounted Plastic Tympani Head..... 26.00
- No. T-28—28" Mounted Plastic Tympani Head..... 28.00
- No. T-29—29" Mounted Plastic Tympani Head..... 29.00

NOTE: Plastic tympani heads come mounted on our special patented* hoops that are included in all prices. No credit can be allowed for the return of your present tympani flesh hoops unless ordering a calf skin tympani head.

*Pat. Pend.

LUDWIG PLASTIC HEAD PRICES:

Available for batter and snare side. Please specify when ordering. All plastic heads mounted on metal flesh hoops. ALL PRICES INCLUDE HOOPS. We cannot use your old hoops—do not return.

Order from your dealer today.

BATTER SIDE

- No. 12—12" Diameter, Mounted.....\$ 6.50
- No. 13—13" Diameter, Mounted..... 7.00
- No. 14—14" Diameter, Mounted..... 7.50
- No. 15—15" Diameter, Mounted..... 8.00
- No. 16—16" Diameter, Mounted..... 8.50
- No. 17—17" Diameter, Mounted..... 9.00
- No. 18—18" Diameter, Mounted..... 9.50

SNARE SIDE

- No. S-13—13" Diameter, Mounted.....\$ 6.00
- No. S-14—14" Diameter, Mounted..... 6.50
- No. S-15—15" Diameter, Mounted..... 7.00
- No. S-16—16" Diameter, Mounted..... 7.50
- No. S-17—17" Diameter, Mounted..... 8.00

When ordering specify whether batter side or snare side desired!

BASS DRUM HEADS

- No. 20—20" Bass Drum Head, Mounted.....\$18.00
- No. 22—22" Bass Drum Head, Mounted..... 19.00
- No. 24—24" Bass Drum Head, Mounted..... 20.00
- No. 26—26" Bass Drum Head, Mounted..... 21.00
- No. 28—28" Bass Drum Head, Mounted..... 22.00
- No. 30—30" Bass Drum Head, Mounted..... 23.00

Ludwig DRUM



LUDWIG CALF HEADS

SELECT FIRST QUALITY PROFESSIONAL CALF BATTER HEADS

	Unmounted	Mounted on Hoop
No. 599—16" for 12" shell.....	\$ 7.30	No. 599M.. \$ 8.80
No. 600—17" for 13" shell.....	7.75	No. 600M.. 9.25
No. 601—18" for 14" shell.....	8.50	No. 601M.. 10.00
No. 602—19" for 15" shell.....	9.25	No. 602M.. 10.75
No. 603—20" for 16" shell.....	10.00	No. 603M.. 11.50
No. 604—21" for 17" shell.....	10.75	No. 604M.. 12.25
No. 605—22" for 18" shell.....	11.50	No. 605M.. 13.00
<small>Heads for No. 2357 Metal Shell Expando Bongos</small>		
No. 606—10" for 6" Metal Bongo	5.00	} Not Supplied Mounted
No. 607—12" for 8" Metal Bongo	7.30	
<small>Heads for No. 2358 Wood Shell Bongos with "Hi Hat" Deep Collar</small>		
No. 608—14" for 6" Bongo.....	6.00	No. 608M.. 8.00
No. 609—16" for 8" Bongo.....	7.30	No. 609M.. 9.30
<small>TUCKED ON YOUR LUDWIG TIMBALES COUNTERHOOP</small>		
No. 611—19" for 13" Timbales...	9.25	No. 611M.. \$13.25
No. 612—20" for 14" Timbales...	10.00	No. 612M.. 14.00

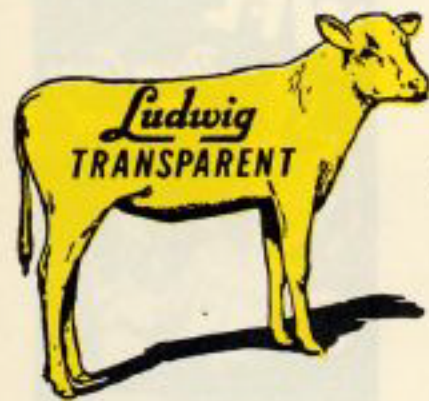

SELECT FIRST QUALITY TRANSPARENT SNARE HEADS

	Unmounted	Mounted on Hoop
No. 650—17" for 13" shell.....	\$ 6.00	No. 650M.. \$7.50
No. 651—18" for 14" shell.....	6.50	No. 651M.. 8.00
No. 652—19" for 15" shell.....	7.00	No. 652M.. 8.50
No. 653—20" for 16" shell.....	7.50	No. 653M.. 9.00
No. 654—21" for 17" shell.....	8.00	No. 654M.. 9.50
No. 655—22" for 18" shell.....	8.50	No. 655M.. 10.00

SELECT FIRST QUALITY PROFESSIONAL ALL-WHITE BASS DRUM HEADS

	Unmounted	Mounted on Hoop
No. 618—25" for 20" shell.....	\$18.20	No. 618M.. \$22.70
No. 619—27" for 22" shell.....	19.90	No. 619M.. 24.40
No. 620—29" for 24" shell.....	22.00	No. 620M.. 26.50
No. 621—31" for 26" shell.....	24.50	No. 621M.. 29.00
No. 622—33" for 28" shell.....	27.00	No. 622M.. 31.50
No. 623—35" for 30" shell.....	28.50	No. 623M.. 33.00
No. 624—37" for 32" shell.....	30.50	No. 624M.. 35.00
No. 625—39" for 34" shell.....	32.50	No. 625M.. 37.00
No. 626—41" for 36" shell.....	34.50	No. 626M.. 39.00

WM. F. LUDWIG "SELECTED" TYMPANI HEADS

Ludwig tympani heads are carefully selected and graded under the personal supervision of Wm. F. Ludwig. Therefore, look for this trademark when you buy:



	Unmounted	Mounted on Your Hoop
No. 669—29" for 23" tympani....	\$29.50	No. 669M.. \$33.50
No. 670—30" for 24" tympani....	30.00	No. 670M.. 34.00
No. 671—31" for 25" tympani....	31.00	No. 671M.. 35.00
No. 672—32" for 26" tympani....	32.00	No. 672M.. 36.00
No. 673—33" for 27" tympani....	33.00	No. 673M.. 37.00
No. 674—34" for 28" tympani....	34.00	No. 674M.. 38.00
No. 675—35" for 29" tympani....	36.00	No. 675M.. 40.00
No. 676—36" for 30" tympani....	38.00	No. 676M.. 42.00

NOTE: For other makes than Ludwig tympani, send your flesh hoop.

DEALER MULTIPLE HEAD RETAINER

Designed for the dealer, this fine retainer holds TWELVE heads for instant transfer to drums. Preserves collar of heads and prevents warping. It's a MUST for every dealer to provide instant head changing service to drummers!



No. 689—Head retainer only, to hold dozen heads..... \$8.00
Available in 12" to 18", specify size.

HEAD TUCKING TOOL



This fine head tucking tool is the type used at the factory. Blade is constructed of finest metal and properly shaped to tuck heads around flesh hoops easily and quickly.

No. 686—Head tucking tool as shown..... \$1.00

FLESH HOOP AND TUCKING PRICES

No. P-680—Wood flesh hoop for snare drum, state batter or snare side and specify size	\$ 0.75
No. P-680A—Metal flesh hoop, state size.....	3.00
No. 681—Tucking head on wood snare or batter hoop...	.75
No. 681A—Tucking head on metal flesh hoop.....	1.00
No. P-682—Wood flesh hoop for Bass Drum, specify size.	3.00
No. 683—Bass drum head tucking on hoop.....	1.50
No. P-684—Tympani flesh hoop, steel, state size.....	8.00
No. 685—Tympani head tucking on steel flesh hoop.....	4.00
No. 687—Ludwig Timbales cast counterhoop, 13" or 14"—specify size desired.....	7.50

NOTE: It is best to return your tympani flesh hoop for factory mounting of new head. This guarantees perfect fit on your tympani.



LUDWIG TYMPANI INSTRUCTOR
A beginning method and hand-book for tympani. Detailed diagrams and instruction on the tuning and care of tympani. Written for student and director. By Wm. F. Ludwig.
No. 1087 \$1.00



MODERN JAZZ DRUMMING
The most complete modern method for the dance drummer available. 96 full pages with over 130 photos and diagrams. Covers every phase of jazz drumming. By Wm. F. Ludwig, Jr.
No. 1050 \$1.00

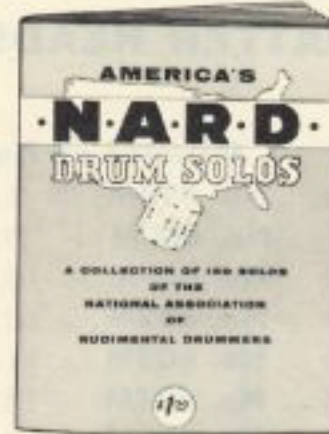

N.A.R.D. SOLOS
A complete compilation of 150 drum solos written by the members of the National Association of Rudimental Drummers. An ideal source for reading material.
No. 1013 \$1.00



SOLO COLLECTION
Contains 45 standard and original solos, 10 assorted duets and ensemble numbers. An ideal source for contest material. By Wm. F. Ludwig.
No. 1010 \$1.00



DRUM INSTRUCTOR
Complete instruction method, covering all phases of percussion. Graded lessons progressively develop the beginning student. Ideal for class or private instruction. By Wm. F. Ludwig.
No. 1060 \$1.00



THE ART OF DRUMMING
Complete instruction on all 26 rudiments with illustrations of the famous "Eastern" style of drumming. By J. Burns Moore.
No. 1065 \$1.00

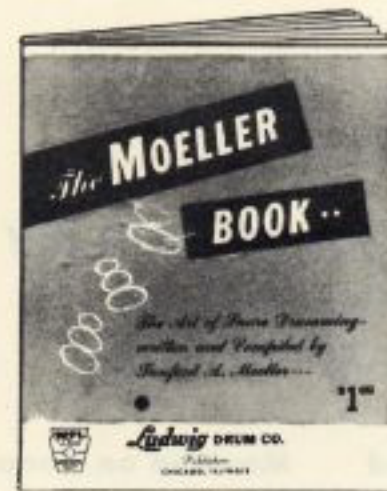

THE MOELLER BOOK
Contains 94 packed pages of snare drum instruction. It's the revised edition of the original Moeller book. By Sanford A. Moeller.
No. 1067 \$1.00



W.F.L. DRUM CORPS MANUAL
A complete drum corps manual covering snare drum, tenor drum, scotch bass drum and bugle. Contains 12 full arrangements for piston bugles.
No. 1070 \$1.00



BATON TWIRLING
A complete twirling guide with the latest in baton tricks. Over 250 illustrations. Also contains flag swinging section.
No. 1000 \$1.00



DRUM MAJOR MANUAL
A complete Drum Major's guide featuring over 50 photos and diagrams of all drum signals. A modern aid for the student drum major.
No. 1005 \$1.00



DRUM & BUGLE MANUAL
The original drum and bugle manual containing the only music for "G" bugles. Covers drum and bugle instruction. By Wm. F. Ludwig.
No. 1072 \$1.00

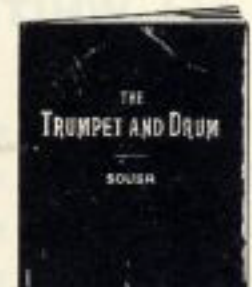

THE TRUMPET AND DRUM
Here is the only instruction book that John Philip Sousa ever wrote, perpetuated for posterity by the Ludwig Drum Co. Contains rudiments of trumpet and drum. By John Philip Sousa.
No. 1014 \$1.00

TEACHING METHODS



MODERN DRUM CADENCES

A collection of modern drum cadences for parade drum, tenor drum and scotch bass drum, featuring fast and standard tempo cadences. By R. L. Schory.

No. 1007 \$.75



DRUM CADENCES 40 NEW STREET CADENCES

Two valuable sources for drum cadence material. Scored for parade drum, cymbals and bass drum. By Hoey-Shinstine.

No. 1001 \$.60
No. 100275



CHAMPION FOLIO NO. 1

A set of 20 separate octavo-sized books plus a full conductor's score. Contains 23 modern arrangements for drums and bugles.

No. 1 \$20.00

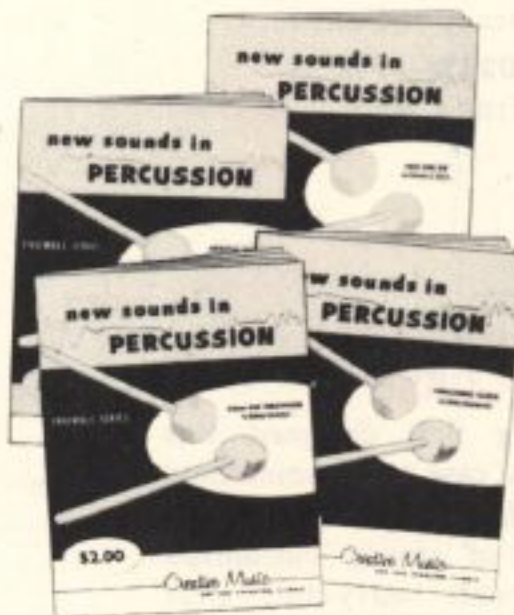

PERCUSSION ENSEMBLE SERIES

A series of modern percussion ensemble numbers for various combinations of percussion instruments. Send for complete list of new releases. Score and parts.

No. 1090A—Poem for Percussion (6 players)..... \$2.00
No. 1090B—Two for Six (6 players) .. 2.00
No. 1090C—Oriental Mambo (10 players)..... 3.50
No. 1090D—Pentatonic Clock (9 players)..... 4.00



VARIATIONS OF DRUMMING

An excellent reading source for the advanced drummer. A "must" for every serious drummer. Contains good material on jazz drumming. By Ralph C. Pace.

No. 1089 \$3.00



THE DRUMMER'S HERITAGE

A collection of popular airs and official U. S. Army music for fifes and drums. Also pieces for field trumpets, cymbals and drums. *Music from Mercury Records.* Compiled by F. Fennell.

No. 1088 \$3.00



STICK CONTROL

An extensive collection of stick control exercises. Recommended for use with standard method book. A "must" for every drummer. By George L. Stone.

No. 1006 \$3.00

RECORDS



THE 13 ESSENTIAL DRUM RUDIMENTS

An excellent teaching aid for the first 13 essential drum rudiments. Also includes 9 favorite contest solos. Played by Wm. F. Ludwig Sr., Wm. F. Ludwig Jr., J. Burns Moore and Ed Straight. Available on 33 1/3 only.

Record No. 1 \$3.00



THE 26 STANDARD AMERICAN DRUM RUDIMENTS

Here is the finest rendition of the 26 Standard American Drum Rudiments ever offered, played by Frank Arsenault, undefeated National Champion Rudimental Drummer. A 12" Hi Fi 33 1/3 recording. Includes solos—duets.

Record No. 2 \$4.00



RE PERCUSSION

An award winning Hi Fi album featuring distinctive musical arrangements for large percussion ensemble. A valuable teaching aid for percussion classes. Featuring RICHARD L. SCHORY and his PERCUSSIVE ART ENSEMBLE.

Record No. 3 \$4.95



LUDWIG'S COMPLETE LINE OF CASES AND COVERS

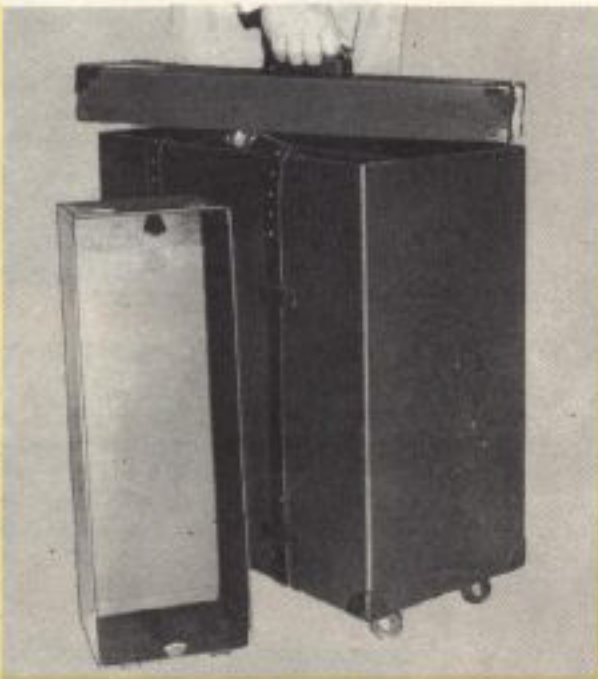

THE PAK 'N ROLL TRAP CASE

An excellent all-purpose trap case designed for the drummer on the go. Holds snare drum, stands, foot pedal, sticks, accessories and all cymbals up to 22" diameter. Four heavy duty roller casters provide easy transport of your heavy equipment.

No. 8021W—Pak 'N Roll Trap Case.....**\$42.00**

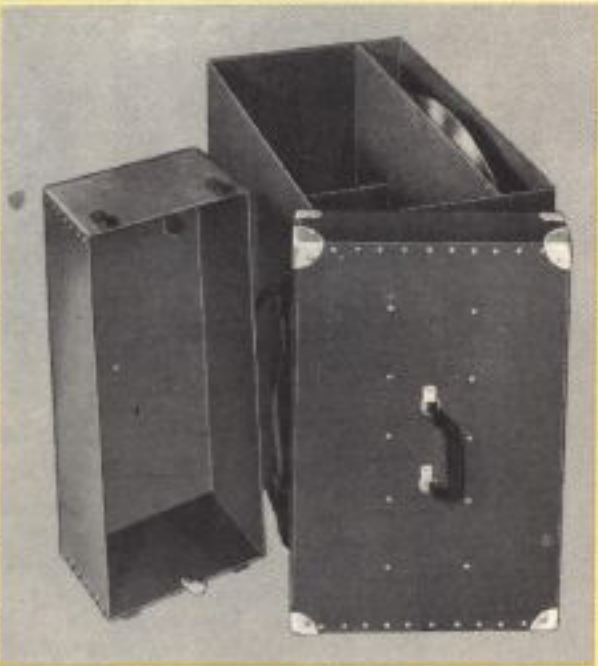

THE HOLD-ALL TRAP CASE

Ludwig first designed this style of case to accommodate those large diameter cymbals. Made of sturdy vulcanized fibre with heavy-duty steel corner guards and sturdy carrying handle. Holds snare drum, cymbals, and all accessories neatly and compactly.

No. 8021—Hold-All Trap Case.....**\$37.50**



SUIT CASE MODEL TRAP CASE

A favorite of the traveling drummer. Trap tray over snare drum holds sticks, stands and small accessories. Adjustable compartment provides maximum protection for snare drum. Deep compartment next to snare drum is designed for pedal and bulky accessories.

No. 7840—Suit Case Model Trap Case....**\$30.00**



No. 8022

TRAP CASE TRAY WITH WHEELS

Designed to attach to the bottom of your present trap case. Simply place case on tray and fasten securely with straps supplied.

No. 8022—Tray With Wheels.....**\$15.00**



No. 1027

THE EXCLUSIVE LUDWIG SEAT-CASE

The Ludwig SEAT-CASE performs a two fold function. It is both an attractive seat which is available in finishes to match your outfit as well as a case to hold all your stands and accessories. Seat is padded and covered with beautiful red leatherette. Supplied with mackintosh zipper cover at no additional cost.

No. 1027—Drummers SEAT -CASE in choice of pearl finish.....**\$47.50**



No. 8026

DRUM KIT CASES

The new line of plush drum kit cases offer attractive appearance plus maximum protection for the instrument. Solid plywood construction, eye catching tweed covering, quality hardware and red plush lining provide years of satisfaction. Available in two models: Standard and DeLuxe. The DeLuxe case features black leather binding as illustrated.

No. 8025—Standard Drummer Kit Case.....**\$24.00**
No. 8026—DeLuxe Drummer Kit Case.....**\$32.00**



No. 8122

FIBRE BONGO CASES

A sturdy fibre bongo case designed to accommodate most sizes of bongos with or without holder attachment. Also an ideal case for tympani sticks, mallets, etc.

No. 8122—Fibre Bongo Case.....**\$15.00**

MACKINTOSH ZIPPER COVERS

Ludwig mackintosh covers are made from the finest materials available. They are top quality water repellent, fleece-lined covers offering years of protection and service. Easy zipper action provides fast packing of drums.

BASS DRUM COVERS

No. 154—12" x 20".....	} \$12.00
No. 155—14" x 20".....	
No. 156—12" x 22".....	
No. 157—14" x 22".....	
No. 54 —14" x 24".....	\$12.75
No. 56 —14" x 26".....	13.50
No. 49 —14" x 28".....	14.40
No. 50 —14" x 30".....	15.30
No. 52 —16" x 32".....	16.20
No. 58 —16" x 34".....	17.00
No. 60 —16" x 36".....	18.50
No. 59 —18" x 40".....	20.00

SNARE DRUM COVERS

No. 33 —3" x 13".....	} \$7.00
No. 33A—4" x 13".....	
No. 33B—5" x 13".....	
No. 34 —4" x 14".....	
No. 30 —5½" x 14".....	
No. 30A—5" x 14".....	
No. 31 —6½" x 14".....	
No. 32 —6½" x 15".....	
No. 32A—8" x 15".....	

SCOTCH BASS DRUM COVERS

No. 46— 8" x 26".....	} \$13.50
No. 47—10" x 26".....	
No. 61— 8" x 28".....	} 14.50
No. 62—10" x 28".....	
No. 63—12" x 28".....	

PARADE DRUM COVERS

No. 38—10" x 14".....	} \$7.50
No. 39—10" x 15".....	
No. 40—12" x 15".....	} 8.00
No. 41—12" x 16".....	
No. 42—12" x 17".....	\$8.50

TOM TOM COVERS

No. 43— 8" x 12".....	} \$7.20
No. 35— 9" x 13".....	
No. 46—14" x 14".....	} 8.40
No. 29—16" x 16".....	



CONCERT KIT CASE

A quality low priced case designed for the 5" x 14" concert drum. Holds drum, stand, sticks, books and small accessories.

No. 7152—Concert Kit Case.....**\$7.50**



FIBRE SNARE CASE

A round telescopic snare drum case with flat bottom, plastic handle and sturdy leather strap. Here is maximum protection for your snare drum.

No. 7150—14" Diameter Snare Drum Case.....**\$14.00**
 No. 7151—15" Diameter Snare Drum Case.....



RAIN COVERS

Quality plastic rain covers designed to completely cover drum in bad weather. Sturdy yet light in weight.

No. 69A—Full Length Rain Cover for 14", 15" and 16" Parade Drums...**\$3.50**

No. 69B—Full Length Rain Cover for 10" x 28" Scotch Drum.....**7.95**

No. 69C—Full Length Rain Cover for 14" x 28" Bass Drum.....**8.25**

(Not available in any other sizes)



PARADE KIT CASE

A square fibre case designed for the economy 10" x 14" parade drum kit. Top protection . . . easy to carry.

No. 7153—10" x 14" Parade Drum Case.....**\$7.50**

FIBRE CASES

PARADE DRUM CASES

No. 6470—10" x 14".....	} \$16.50
No. 6571—10" x 15".....	
No. 6671—12" x 15".....	} 18.00
No. 6772—12" x 16".....	
No. 6873—12" x 17".....	\$21.00

TOM TOM CASES

No. 8361— 8" x 12" Diameter.....	} \$14.50
No. 8362— 9" x 13" Diameter.....	
No. 8464—14" x 14" Diameter.....	\$18.00
No. 8565—16" x 16" Diameter.....	20.00
No. 8866—16" x 18" Diameter.....	25.00
No. 8567—Combination 9" x 13" and 16" x 16" tom tom case.....	35.00

BASS DRUM CASES

No. 6890A—12" x 20" Diameter.....	} \$32.50
No. 6890 —14" x 20" Diameter.....	
No. 6991A—12" x 22" Diameter.....	
No. 6991 —14" x 22" Diameter.....	
No. 8680 —14" x 24" Diameter.....	} 35.00
No. 8681 —14" x 26" Diameter.....	
No. 8687A— 8" x 26" Diameter.....	
No. 8687 —10" x 26" Diameter.....	} 36.00
No. 8688 —10" x 28" Diameter.....	
No. 8688A—12" x 28" Diameter.....	} \$38.00
No. 8682 —14" x 28" Diameter.....	
No. 8683 —14" x 30" Diameter.....	48.00
No. 8684 —16" x 32" Diameter.....	54.00
No. 8685 —16" x 34" Diameter.....	60.00
No. 8686 —16" x 36" Diameter.....	75.00
No. 8687 —18" x 40" Diameter.....	31.00
No. 8890 —24" x 16" Diameter Cocktail lounge drum case.....	33.00
No. 8789 —28" x 23" Diameter Compacto case..	

PEDAL PARTS



NO. 205

BLUE "REVERSIBLE" SPEED PEDAL

P-1265	Reversible Footboard Assembly.....	\$6.00
P-1271	Rocker Shaft Assembly.....	5.00
P-1323	Leather strap with screw.....	.75
P-1273	Rocker link.....	.50
P-245	Thumb screw nut only.....	.15
P-1324	Ball bearing only.....	1.00
P-1319	Yoke Assembly.....	2.00
P-1206N	Toe Clamp Assembly, nickel.....	1.50
P-1317	Spring hook.....	.60
P-1315	Tension spring only.....	.25
P-1246	Spring adjustment screw.....	.35
P-1247	Tension adjustment nut only.....	.25
P-1287	Adjustment screw for toe clamp.....	.50
P-1269	Rocker shaft bushing.....	.25
P-111	Hex cap nut.....	.25
P-306	Lock washer.....	.05
P-1240	Beater rod screw.....	.30
P-313	1/4" Internal lock washer.....	.05

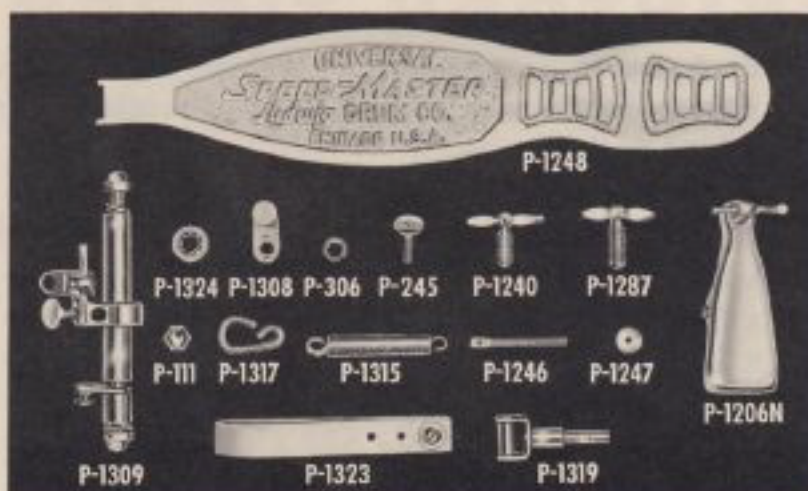
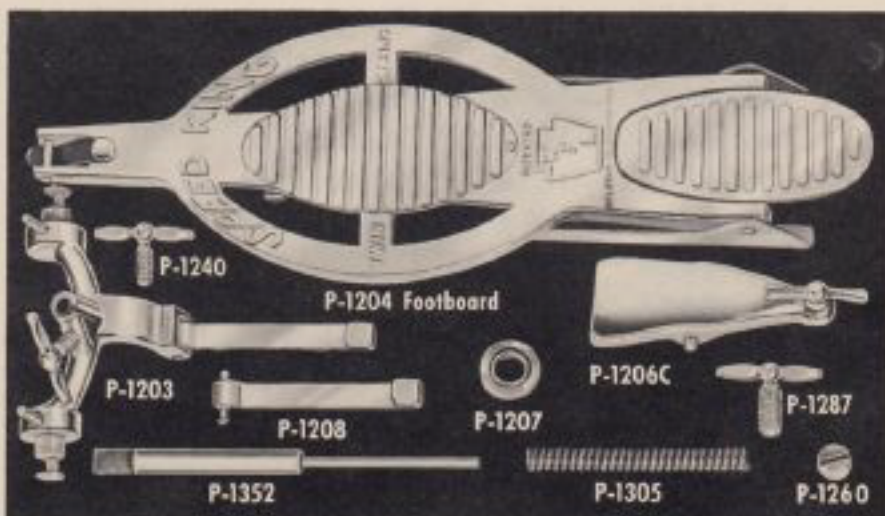
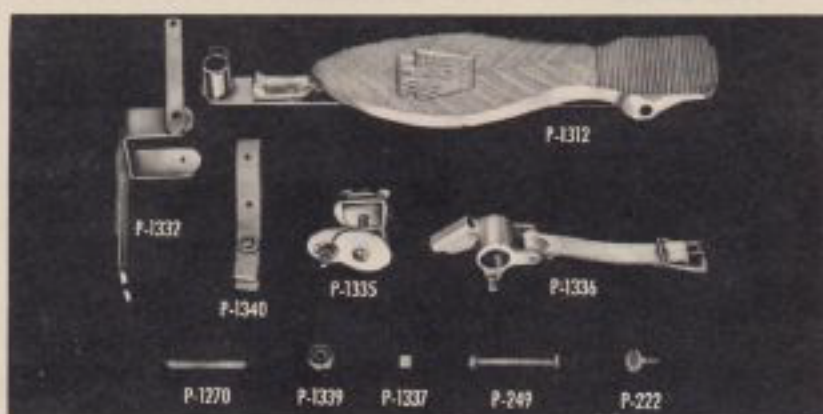

NO. 252 RED UNIVERSAL SPEEDMASTER PEDAL

P-1248	Speedmaster Footboard Assembly ...	\$3.00
P-1240	Beater Rod Adjustment Screw.....	.50
P-1309	Rocker Shaft Assembly Complete....	5.00
P-1206N	Toe Clamp, nickel.....	1.50
P-1287	Adjustment Screw for Toe Clamp....	.50
P-1315	Tension Spring.....	.25
P-1246	Spring Adjustment Screw.....	.35
P-1247	Tension Adjustment Nut.....	.25
P-1319	Yoke Assembly Complete.....	2.00
P-111	Hex Cap Nut.....	.25
P-1324	Ball Bearing.....	1.00
P-1308	Rocker Shaft Link.....	.50
P-306	Lock Washer.....	.05
P-245	Thumb Screw.....	.15
P-1323	Leather Strap with screw.....	.75
P-1317	Spring Hook.....	.60

NO. 206 JUNIOR PEDAL

P-1291	Footboard Assembly.....	\$4.00
P-1325	Leather Strap Assembly.....	.75
P-1206N	Toe Clamp.....	1.50
P-1292	Rocker Shaft.....	4.50
P-1287	Toe Clamp Screw.....	.50
P-1240	Beater Rod Screw.....	.30
P-1295	Tension Spring.....	.40
P-1326	Rocker Arm Assembly.....	2.00
P-1308	Rocker Shaft Link.....	.50
P-1293	Nylon Bushing.....	Each .30
P-1247	Tension Nut.....	.25
P-1296	Adjusting Screw.....	.35
P-245	1/2" Thumb Screw.....	.15
P-259	3/8" Lg. Cap Screw.....	.10
P-311	Flat Washer 1/4".....	.05
P-307	1/4" Ext. Tooth Lock Washer.....	.05

NO. 208 UPBEAT PEDAL

P-1312	Footboard Assembly.....	\$6.00
P-1332	Fork Sub-Assembly.....	4.00
P-1336	Rocker Sub-Assembly.....	3.50
P-1335	Support Assembly.....	2.50
P-1340	Footboard Strap Assembly.....	.75
P-222	3/8" Large Thumb Screw.....	.15
P-249	2" Machine Screw Assembly.....	.50
P-1337	Rocker Bushing.....	.50
P-1339	Ball Bearing.....	1.00
P-1270	Spring.....	.40

NO. 201 SPEED KING PEDAL PARTS

P-1204	Speed King Footboard assembly.....	\$6.00
P-1201	Footboard Spring (not shown).....	.20
P-1240	Adjustment screw for beater rod.....	.30
P-1203	Rocker shaft assembly complete.....	5.00
P-1208	Connecting link and pin.....	.75
P-1207	Ball bearing only.....	1.50
P-1206C	Toe clamp and screw with pin.....	1.50
P-1287	Adjustment screw for toe clamp.....	.50
P-1352	Plunger only.....	1.00
P-1305	Compression spring only.....	.50
P-1260	Adjustment screw for spring.....	.25
P-1227	Sealing cap only (not shown).....	.20

PEDAL PARTS

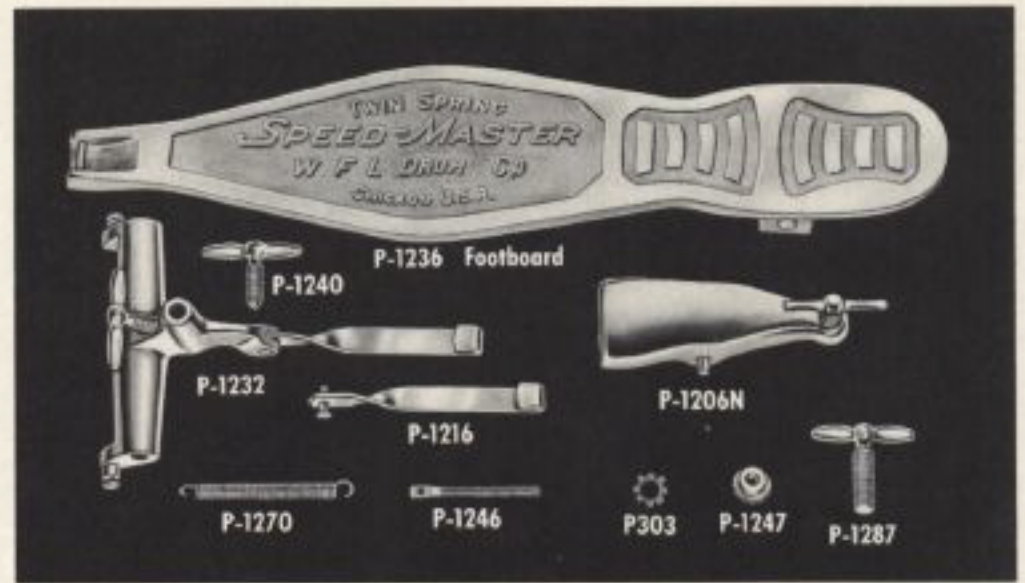
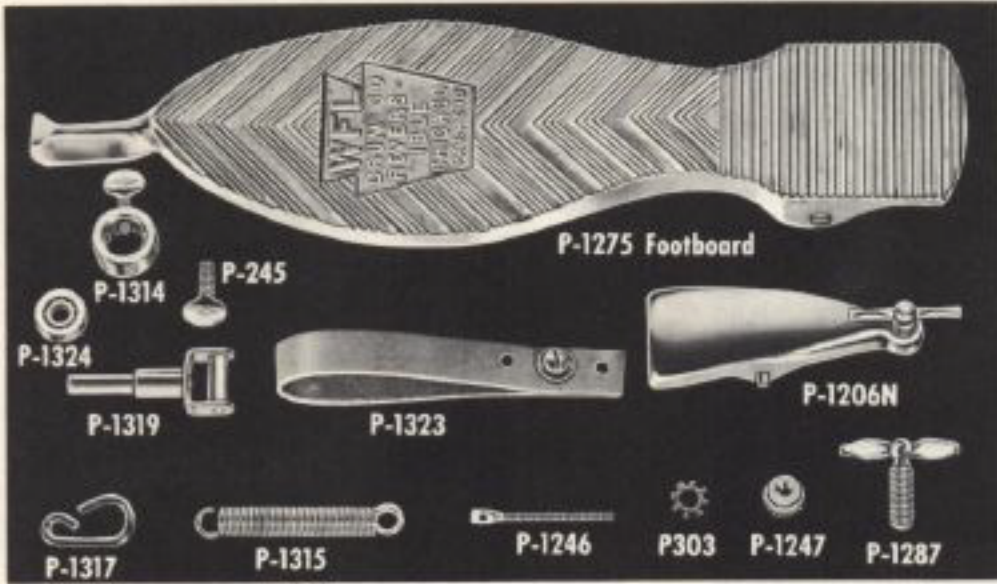

REPLACEMENT REVERSIBLE PEDAL PARTS

P-1275	—Reversible pedal footboard, assem.	\$5.00
P-1323	—Leather strap assem.	.75
P-1314	—Collar and thumb screw only	2.00
P-245	—Thumb screw	.15
P-1324	—Ball bearing only	1.00
P-1319	—Yoke assembly complete	2.00
P-1206N	—Toe clamp assembly, nickel	1.50
P-1317	—Spring hook	.60
P-1315	—Tension spring only	.25
P-1246	—Spring adjustment screw	.35
P-303	—Star lock washer only	.05
P-1247	—Tension adjustment nut only	.25
P-1287	—Adjustment screw for toe clamp	.50

REPLACEMENT SPEEDMASTER PEDAL PARTS

P-1236	—Speed Master Pedal Footboard, assem.	\$5.00
P-1240	—Adjustment screw for beater rod	.30
P-1232	—Rocker shaft assembly, complete	4.00
P-1216	—Connecting link and pin	.75
P-1206N	—Toe clamp, nickel	1.50
P-1287	—Adjustment screw for toe clamp	.50
P-1270	—Tension spring only	.40
P-1246	—Spring adjustment screw only	.35
P-303	—Star lock washer only	.05
P-1247	—Tension adjustment nut	.25

HOOPS

DRUM HOOPS

When ordering hoops give size and state whether for batter or snare side! Specify on metal hoops whether 6, 8 or 10 holes are desired.

	<i>Nickel</i>
P-164	—Inlaid wood bass drum hoops..... \$6.00
P-160	—Plain wood bass drum hoops..... 4.00
P-158	—Triple flange metal batter hoop..... 6.50
	<i>Chrome \$7.50</i>
P-158S	—Triple flange metal snare hoop..... 6.50
	<i>Chrome \$7.50</i>
P-150	—Wood parade drum hoop, batter..... 2.50
P-150S	—Plain wood hoop, snare side..... 2.50
P-151	—Inlaid par. dr. hoop, batter side..... 3.40
P-151S	—Inlaid snare side wood hoop..... 3.40
P-680	—Flesh hoop up to 18" dia..... .75
P-682	—Bass drum flesh hoop..... 3.00
P-684	—Steel tympani flesh hoop, cad, plated.... 8.00

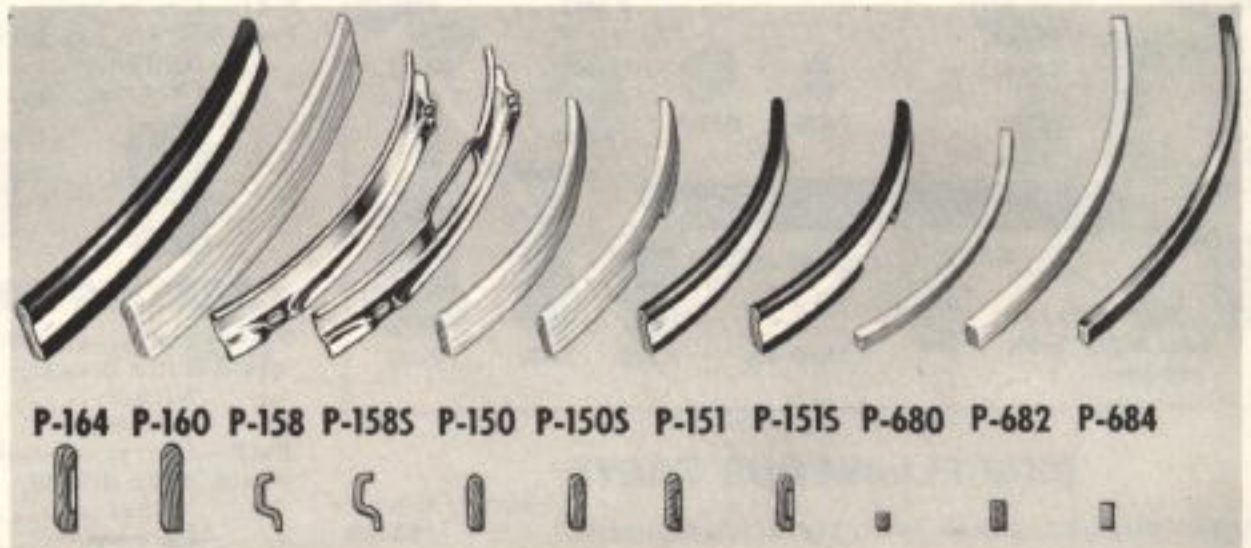

TYMPANI TENSION KEY

P-1501—Tympani tension key for key tension rods, chrome..... \$3.00



TYMPANI RODS AND KEYS

P-1556	—Symphony Tympani rod 5" overall.....	\$2.50
P-1502	—Universal tympani rod, 4 3/8" overall.....	2.50
P-1549	—Key tension Symphony rod 3 13/16", square head.....	2.50
P-1502K	—Key tension Universal rod, 3 1/8" overall, square head....	2.50

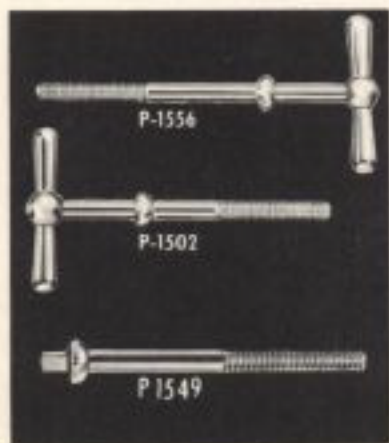

tone CONTROL

P-4066—Tone control..... \$2.50

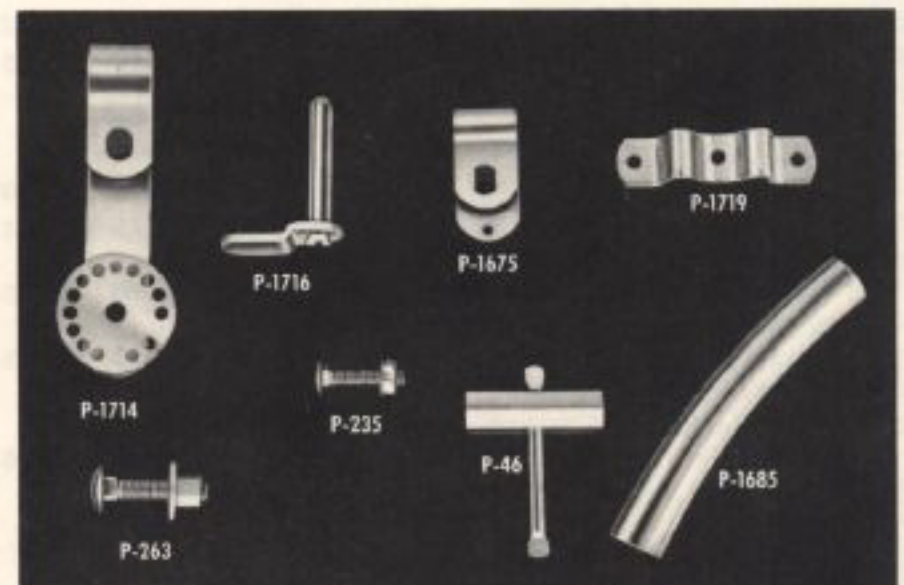

NO. 782 TOM TOM HOLDER PARTS

	<i>Nickel</i>	<i>Chrome</i>
P-1714	—Bar clamp assembly complete.....	\$4.50 \$5.00
P-1716	—Clip and post assembly.....	2.00 2.50
P-1675	—Rod clamp.....	.75 1.00
P-1719	—Base bracket to support rail.....	1.50 2.00
P-235	—1/4-20 Carriage bolt assembly.....	.20 .30
P-263	—3/16"-18 Carriage bolt assembly.....	.30 .40
P-46	—Hex tensioning wrench.....	1.00
P-1685	—Curved mounting rail.....	4.50 5.50

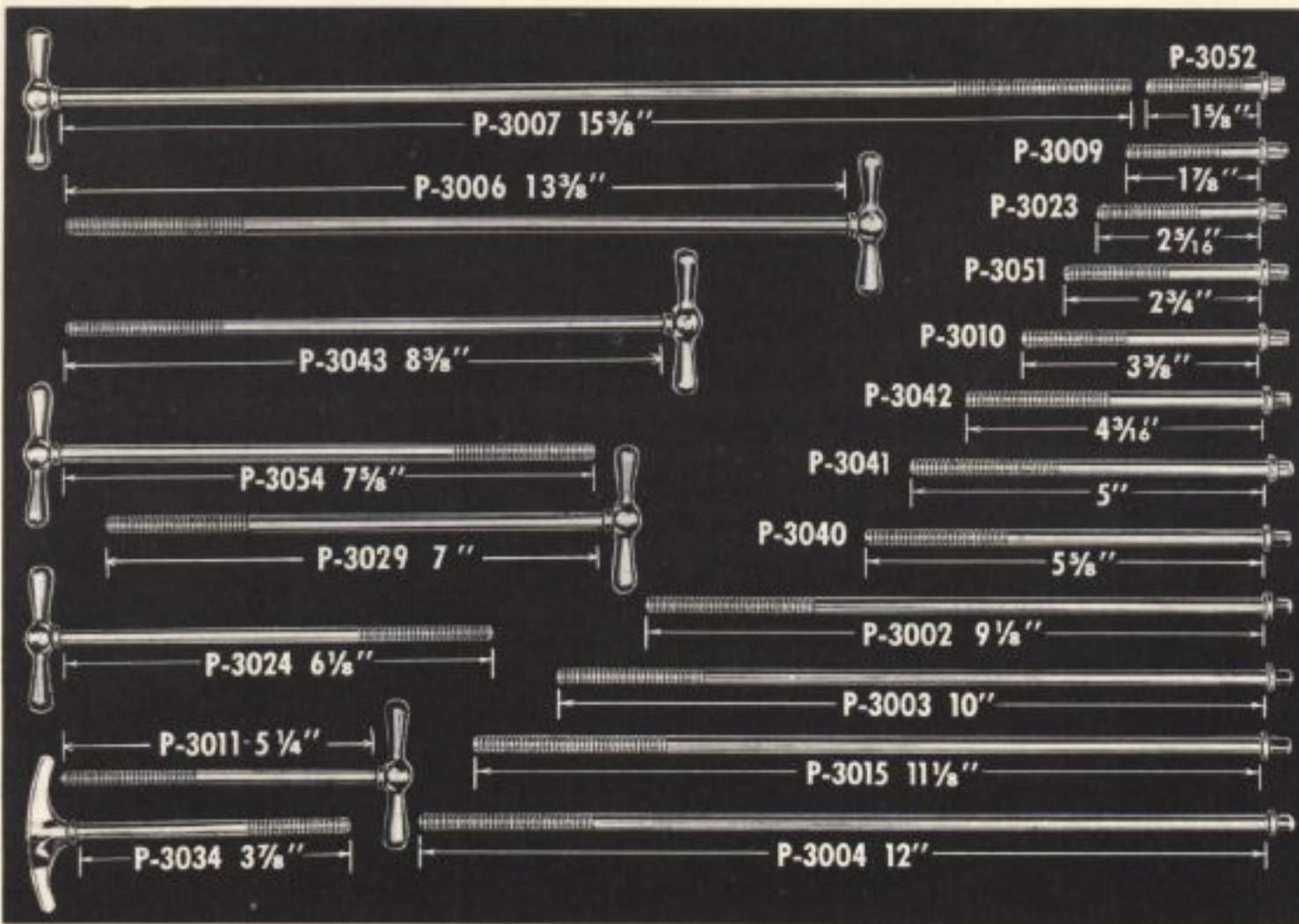

TENSION RODS
 When ordering Ludwig drum rods, use catalog number and supply additional information such as length and finish (nickel or chrome.)
 Measure from shoulder to end of threads—not over-all. Only 12-24 threads are supplied. No other lengths than these are available. Refer to illustration at left for accuracy.

DRUM KEY RODS

P-3052	—1 3/8" key rod..	} Nickel Chrome
P-3009	—1 7/8" key rod..	
P-3023	—2 1/6" key rod..	
P-3051	—2 3/4" key rod..	
P-3010	—3 3/8" key rod..	
P-3042	—4 3/16" key rod..	
P-3041	—5" key rod..	
P-3040	—5 3/8" key rod..	
P-3002	—9 1/8" key rod..	
P-3003	—10" key rod..	
P-3015	—11 1/8" key rod..	
P-3004	—12" key rod..	

"T" HANDLE BASS DRUM RODS

P-3034	—3 7/8" "T" handle rod with die cast tension handle.....	} Nickel Chrome
P-3011	—5 1/4" Brass handle tension rod.....	
P-3024	—6 1/8" Brass handle tension rod.....	
P-3029	—7" Brass handle tension rod.....	
P-3054	—7 3/8" Brass handle tension rod.....	
P-3043	—8 3/8" Brass handle tension rod.....	
P-3006	—13 3/8" Brass handle tension rod.....	
P-3007	—15 3/8" Brass handle tension rod.....	

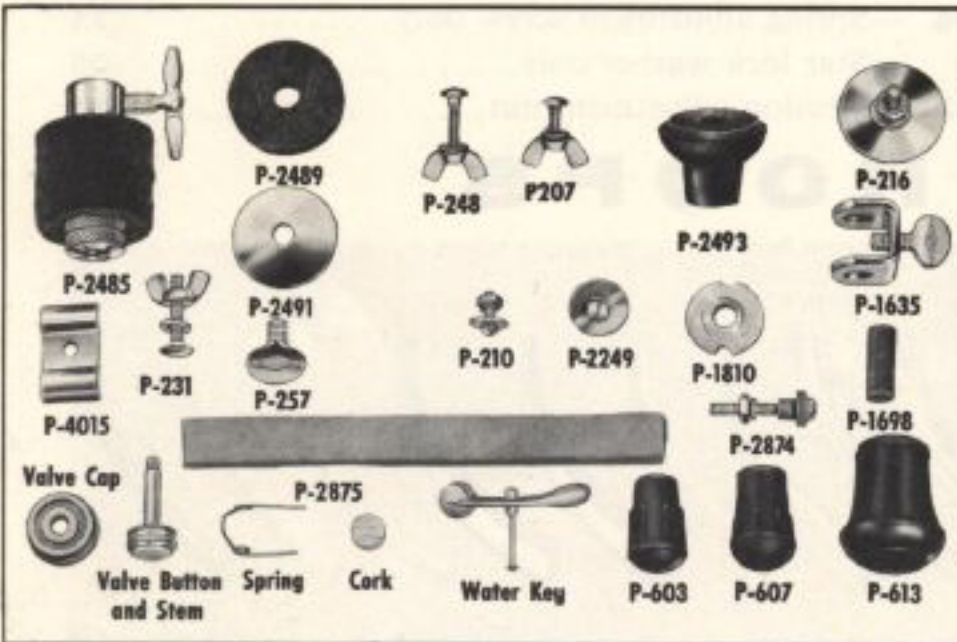

MISCELLANEOUS PARTS

P-2485	—High hat clutch assembly, steel, complete.	Nickel	Chrome
P-2489	—Felt washer for high hat clutch, each	.10	
P-2491	—Metal washer for high hat clutch, each	.20	.30
P-207	—Bolt, washer, and wing nut for all stands	.10	.15
P-2493	—Molded rubber Hi Hat cymbal seat and washer insert	.50	
P-216	—Washer, screw and nut assembly for tom tom leg bracket	.30	.40
P-4015	—Clip for No. 476 rod mount leg rest, each	.15	.25
P-231	—Bolt, washer, and wing nut for rod mount leg rest clip	.10	.15
P-248	—Bolt, washer, and wing nut for #1026 drummer's throne	.10	.15
P-257	—Thumb screw for Bell Lyra	.07	
P-210	—Bolt, washer and nut for mounting strainers or snare butts	.10	.15
P-2249	—Bolt and washer "sem" to mount lugs to drum shell, each	.10	.15
P-1810	—Plastic nut for tympani sticks, each	.20	
P-1635	—"U" clamp with wing nut for cow bell holder	.50	.60
P-1698	—Rubber tubing for top of cymbal rods, each	.05	
P-2874	—Bolt, felt washer, and nut to mount bell lyra bars, each	.10	
P-2875	—Felt strip for bell lyra rail, each	.20	
P-603	—Rubber crutch tip for spurs, snare stands	.05	
P-613	—Rubber crutch tip for bass drum stand	.10	
P-607	—Rubber crutch tip for drummer's throne	.10	
Specify type and/or finish on following items.			
Valve cap for bugles, each		.35	
Valve stem for bugles, each		.50	
Water key spring for bugles, each		.10	
Cork for water keys, each		.05	
Water key assembly, complete, each		1.00	1.50

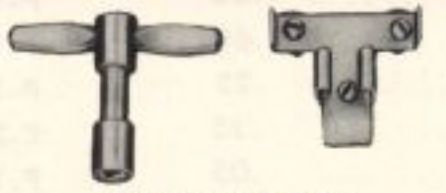

DRUM KEY AND HOLDER

P-41	—Drum key.....	\$0.40
P-42	—Drum key holder, Nickel.....	\$0.35
	Chrome.....	\$0.45

CARRYING HOOKS

P-44	—Carrying hook for wood hoop drums, Nickel.....	\$0.15
	Chrome.....	\$0.25
P-47	—Carrying hook for metal hoop drums, Nickel.....	\$0.15
	Chrome.....	\$0.25

P-208 —Eyebolt carrying hook assembly with inner reinforcing block, each, Nickel.....\$0.75 Chrome.....\$1.00

P-2489 —Felt washer for cymbal holders .. \$0.10
P-2222 —Drum center support washer10
P-3012 —Tension rod spacer washer10

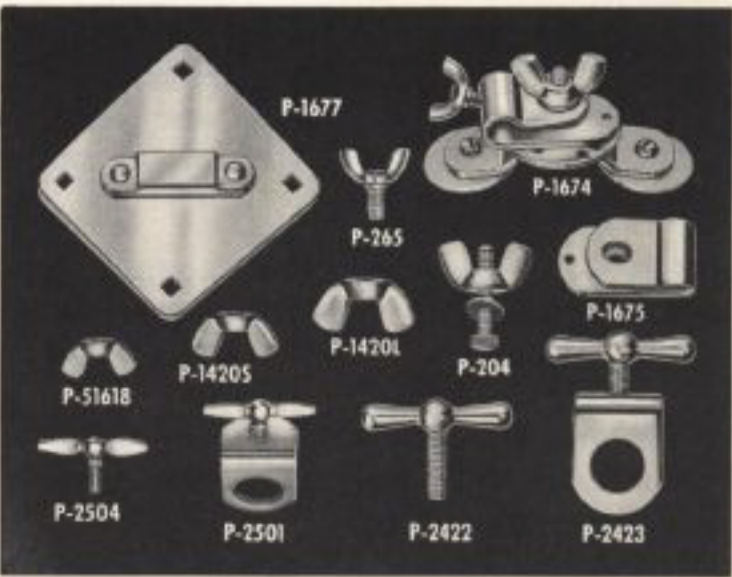

HOLDER AND STAND PARTS

P-1677	—Diamond plate for shell mount tom tom holder—fits on 8" x 12" or 9" x 13" tom tom, with mounting bolts.....	Nickel	Chrome
P-1674	—Bracket for shell mount cymbal holder.....	3.00	3.50
P-51618	—Small wing nut	.10	.15
P-1420S	—Medium wing nut	.10	.15
P-1420L	—Large wing nut for cymbal bracket.....	.10	.15
P-204	—Bolt, washer & wing nut assembly for hoop mount holder bracket.....	.25	.30
P-1675	—"U" clamp only for cymbal bracket.....	.75	1.00
P-2504	—Tension screw for all stands	.30	.40
P-2422	—"T" handle bolt for drummer's throne clip.....	.30	.40
P-2423	—Drummer's throne clip and screw assembly.....	1.75	2.00
P-2501	—Snare drum stand clip and screw assembly.....	1.50	2.00
P-265	—Thumb screw only for #1674		.15

TYMPANI CASTERS

P-1584	—3" diameter caster with lock for Ludwig #893 Universal tympani, each	\$2.00
P-1436	—2 1/2" diameter caster with lock for Ludwig Symphony and Professional tympani, each	\$2.00



DOUBLE CLAW HOOKS

P-2304—Plain hook without threads for key tension collar screw rods

P-2300—Plain hook without threads for "T" handle bass drum rods. *Nickel Chrome*

P-2303—Threaded hook for all single tension rods at tension side....

\$0.60 \$0.90



CENTER SUPPORT STUDS

P-2249—Bolt and washer (sem) 8-32 x 3/8" to mount stud center supports to *Nickel Chrome* drum shell.....**\$0.10**

P-2219—Field drum center support stud complete with sem.....

P-2218—Bass drum center support stud complete with sem.....

\$0.40 \$0.50

TYMPANI TUNING GAUGE LETTERS

P-1442—Letter for 25" tympani A through F, each.**\$0.15**

P-1443—Letter for 28" tympani F through D, each.**\$0.15**



TUNING GAUGE ADJUSTMENT SCREW



P-1444—Adjustment screw for #899 tuning gauge, each.....**\$0.10**

RUBBER SUCTION CUP



P-614—Rubber suction cup for #355 practice pad, each.....**\$0.30**



DRUM THRONE SEAT CASTING

P-2416—Support casting for #1026 drummer's throne with screws.....**\$3.00**

EXPANDO BONGO TUNING WHEELS

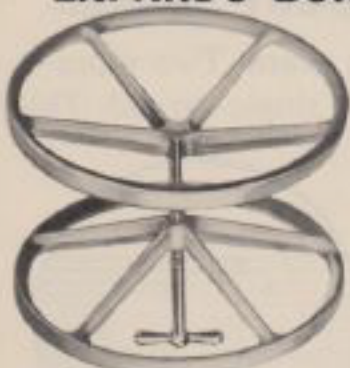

P-2148—Wheel for 6" bongo per wheel.....**\$2.00**

P-2149—Wheel for 8" bongo per wheel.....**\$2.00**

Specify top or bottom wheel

P-3017—"T" handle tension screw for either size Expando bongo, nickel only, each....**\$2.00**

PLASTIC SLEEVE

P-2446—Plastic sleeve, for snare drum stand, black only, each.....**\$0.20**



TENSION CASINGS

Nickel Chrome

P-95—Twin separate tension casing with spring and two self-aligning swivel nuts.... **\$1.00 \$1.25**

P-2242—Twin spring only... **.05**

P-2247—Swivel nut only for Twin casing..... **.20 .30**

P-96—Large Classic sep. tension casing, with spring and swivel nut..... **1.00 1.25**

P-2245—Spring for large Classic casing..... **.05**

P-2244—Swivel nut only for large Classic lug..... **.20 .30**

P-97—Small Classic tension casing with spring and swivel nut..... **1.00 1.25**

P-2248—Spring for small Classic lug only..... **.05**

P-2247—Swivel nut for small Classic lug..... **.20 .30**

P-87 CLASSIC SNARE STRAINER

P-87—Classic snare strainer, complete *Nickel*..... **\$10.00**
Chrome..... **12.50**

P-1088—Tension nut for Classic strainer..... *Nickel*..... **\$1.00**
Chrome..... **1.25**

P-1085—Throw-off lever only..... *Nickel*..... **\$1.85**
Chrome..... **2.35**

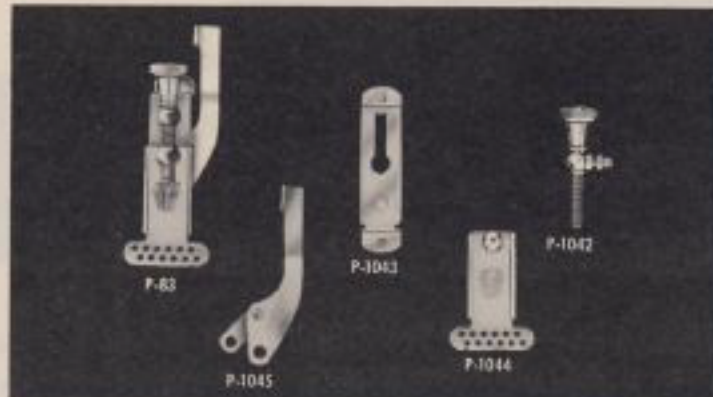

P-83 SNARE STRAINER

Nickel Chrome

P-83—Throw-off strainer, with mounting screws..... **\$2.50 \$3.00**

P-1043—Base assembly with rivet..... **.60 .70**

P-1042—Tension screw assembly..... **.80 .95**

P-1045—Lever assembly..... **.70 .80**

P-1044—Slide assembly..... **.70 .80**

P-85 LARGE PIONEER STRAINER

Nickel Chrome

P-85—Large Pioneer strainer assembly..... **\$4.50 \$5.50**

P-1012—Base bracket assembly with rivet..... **1.50 1.75**

P-1013—Hex adjustment tension screw assembly..... **2.00 2.25**

P-1009—Lever throw-off sub assembly..... **.65 .75**

P-1011—Slide bracket assembly..... **.80 1.00**

P-32—Snare butt for all strainers. *Nickel*..... **\$.75**
Chrome..... **1.00**

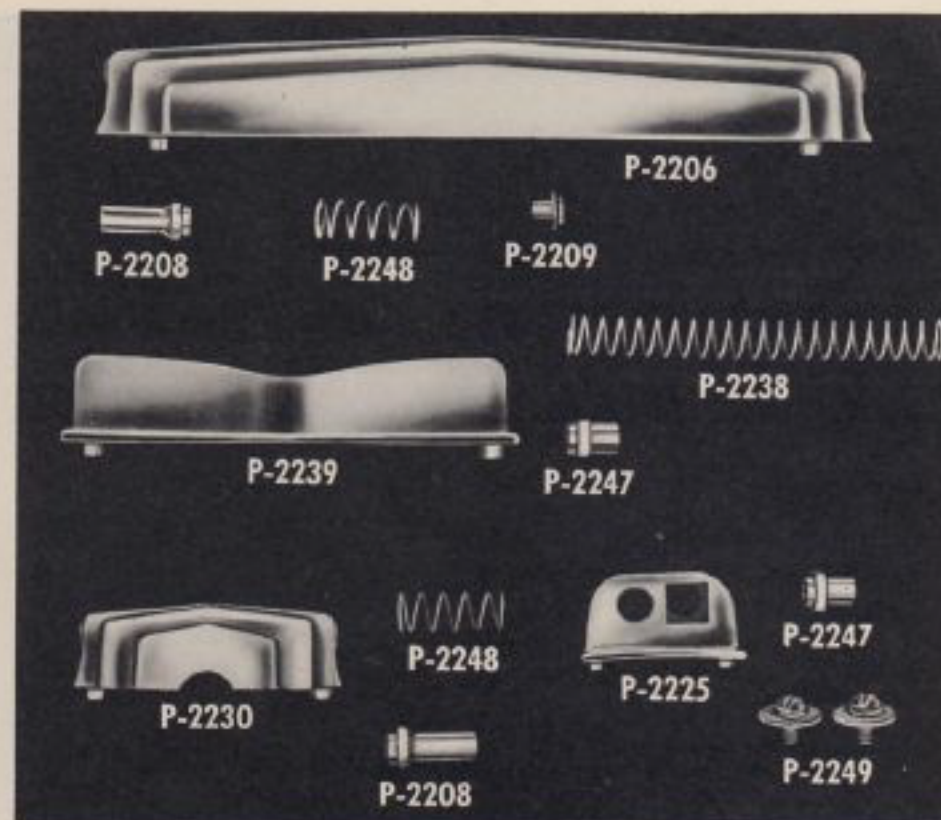
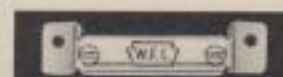

NEW LUDWIG TENSION CASINGS

All tension casings are supplied complete with screws (sems) for mounting to shell.

Nickel Chrome

P-2206—Long Imperial bass drum sep. tension casing with spring and swivel nuts. **\$1.30 \$1.50**

P-2208—Long swivel nut for Imperial lug. **.20 .30**

P-2248—Spring for Imperial casing..... **.08**

P-2209—Spring stud inside casing..... **.15**

P-2239—Large Twin tension casing with spring and swivel nuts..... **1.15 1.30**

P-2238—Spring for large Twin casing..... **.05**

P-2247—Swivel nut for large Twin casing.. **.20 .30**

P-2230—Small sep. tension Imperial lug for metal snare drum with spring and swivel nuts..... **1.00 1.20**

P-2248—Spring for small Imperial lug..... **.05**

P-2208—Swivel nut for small Imperial lug. **0.20 0.30**

P-2225—Be Bop tension casing without swivel nuts but with sems..... **1.00 1.20**

P-2247—Swivel nut, small, for Be Bop lug. **.20 .30**

P-2249—Sems 8-32 x 3/8", each..... **.10**



P-84 SMALL PIONEER STRAINER

Nickel Chrome

P-84—Small Pioneer strainer assembly..... **\$2.50 \$4.00**

P-1007—Bracket sub assembly with rivet..... **1.00 1.25**

P-1000—Tension screw assembly **1.50 2.00**

P-1009—Throw-off lever sub assembly with rivet..... **.75 1.00**

P-1002—Slide assembly..... **.75 1.00**

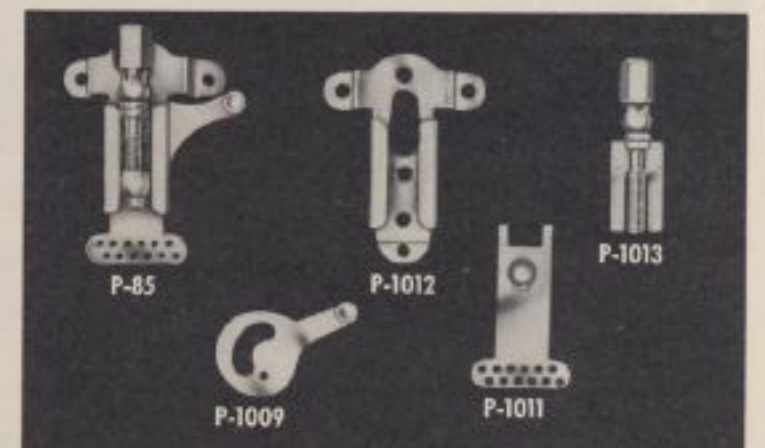

LUDWIG SNARES

When ordering snappi-wire snares illustrated at left, specify over-all length including snare plates when stretched taut. State number of strands and weight desired—thin or heavy. Compare your snares with illustration and order by code letter.

Gut snares and silk-wire snares fit all diameters.

STATE OVER-ALL LENGTH, WEIGHT, NUMBER OF STRANDS AND CODE LETTER

A	12½" for 13" dia. drum, regular thin wire, 12 strand.....	\$3.00
B	13½" for 14" dia. drum, regular thin wire, 12 strand.....	3.00
C	14½" for 15" dia. drum, regular thin wire, 12 strand.....	3.00
D	13½" for 14" dia. drum, regular heavy wire, 12 strand.....	3.00
E	14½" for 15" dia. drum, regular heavy wire, 12 strand.....	3.00
F	15½" for 16" dia. drum, regular heavy wire, 12 strand.....	3.00
G	13⅜" for 13" dia., new Classic short, thin, 18 strand.....	3.50
H	14⅜" for 14" dia., new Classic short, thin, 18 strand.....	3.50
J	15⅜" for 15" dia., new Classic short, thin, 18 strand.....	3.50
L	16" for 14" dia., old Classic long, thin, 18 strand.....	3.50
M	17" for 15" dia., old Classic long, thin, 18 strand.....	3.50
N	13⅝" for 14" dia., regular thin wire, 20 strand.....	3.50
P	14⅝" for 15" dia., regular thin wire, 20 strand.....	3.50
Q	Two-tone wire-gut snares fit all diameters, 12 strand.....	5.00
R	Two-tone wire-gut for Classic snare strainer, to fit all diameters, 12 strand.....	5.00

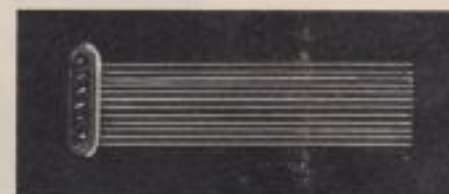
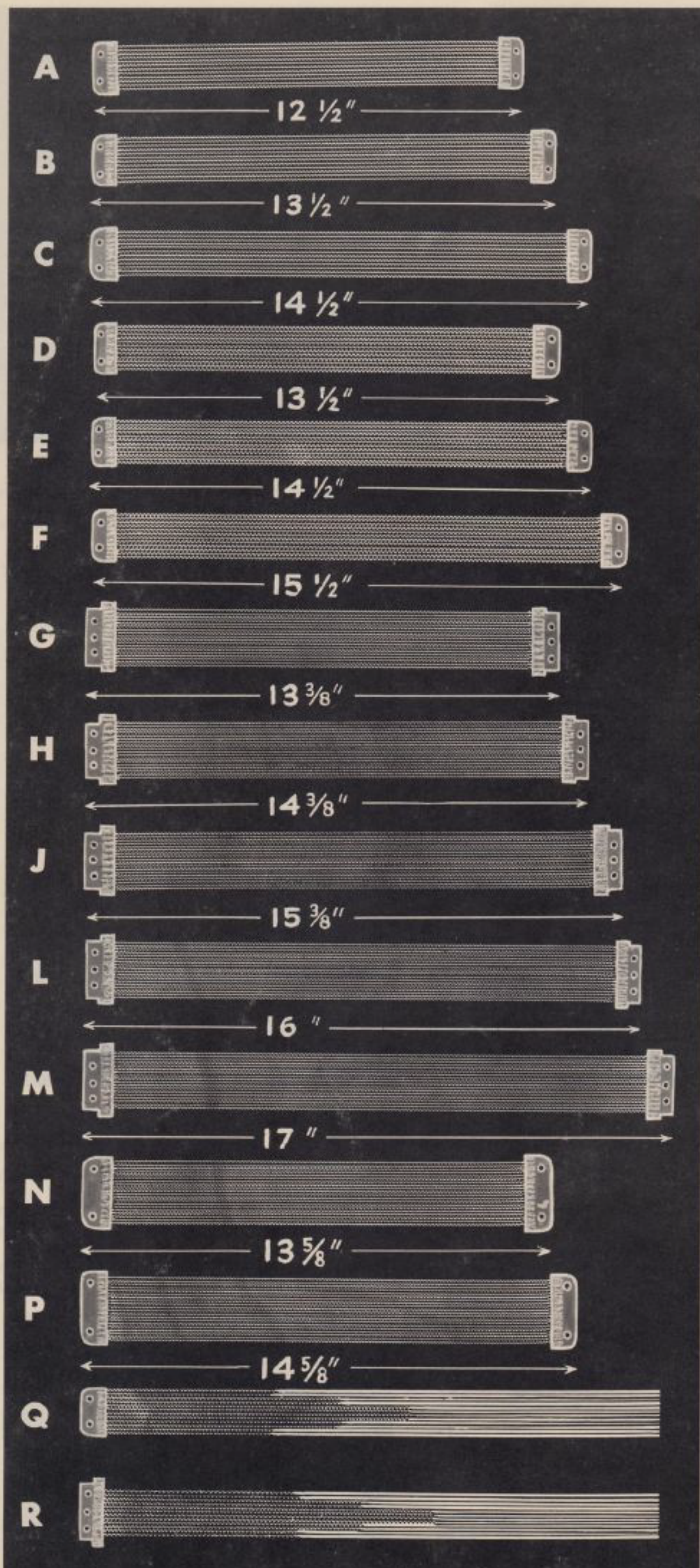

**P104 GUT SNARES
LIGHT OR HEAVY**

GUT SNARES ARE SOLD WITH FIBER BUTT PLATE INCLUDED IN THE PRICE

P-104	—Gut snares, 12 strands, light weight.....	\$4.00
P-104A	—Gut snares, 12 strands, heavy weight.....	4.50
P-106	—Fibre butt plate only.....	.10

NEW "TWO-TONE" WIRE-GUT SNARES

The greatest snare advancement in years! Two types—wire and gut are combined in a single strand. This provides the sensitivity of *wire snares* with the power and volume of *gut snares*. It's the best-sounding, best-playing snare ever constructed.

No. Q—Two-Tone Wire-Gut Snares to fit any size parade drum..... **\$5.00**

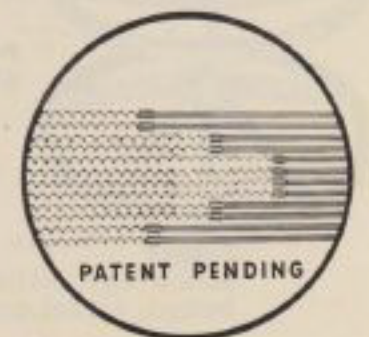

Available on all parade or concert drums at time of order, additional with the drum **\$3.00**



PEARL FINISHES

Ludwig pearl finishes are the product of one of the world's leading chemical manufacturers. They are the finest finishes available and will add extra life and lasting beauty to your drums. The hard surface will not scratch, peel or chip.

Ludwig now offers the new *Multi-Sparkle** pearl, combining any two of the 5 sparkling finishes. *Multi-Sparkle** pearl is another Ludwig quality feature available at no extra cost. When ordering—specify outer color first, inner color second.



SKY BLUE PEARL



WHITE MARINE PEARL

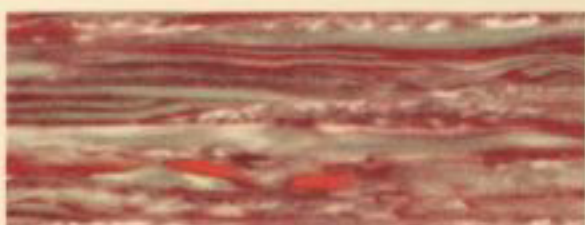

OYSTER PINK PEARL



OYSTER BLACK PEARL



BLACK DIAMOND PEARL



OYSTER BLUE PEARL



JET BLACK PEARL



SPARKLING BLUE PEARL



SPARKLING SILVER PEARL



SPARKLING GOLD PEARL



SPARKLING GREEN PEARL



SPARKLING RED PEARL

index

B

Bass Drum Stand.....	10
Beaters	39
Bell Lyra and Accessories.....	52
Bird Whistle	48
Bongo Drums.....	13, 51
Bongos Holders and Stands.....	12
Bugles	35, 36, 37
Bugle Cases	36

C

Castanets	48
Cases and Covers.....	58, 59
Claves	14
Conga Drums	12
Cow Bells and Holders.....	49
Cymbals	41
Cymbal Holders.....	44, 45, 49
Cymbal Pouch	41

D

Drum Key	62
Drum Kits	6, 7
Drum Outfits... 16, 17, 18, 19, 20, 21, 22	
Drum Records	57
Drum Rods	62
Drum Stand.....	46, 47

F

Field Drums.....	24, 25, 26, 27, 28
Flags	53

G

Gongs	41
Gong Stand	41
Guiro	14

H

Heads	54, 55
Head Lettering	51
Head Retainer	55
Hi-hat Sock Pedal.....	46, 47
Hooks, Rods, Parts.....	61, 62, 63
Hoops, all type.....	61

I

Instruction Books.....	56, 57
------------------------	--------

K

Ka-Me-So	14
----------------	----

L

Leg Rests	28
-----------------	----

M

Maracas	14
Mufflers, Bass Drum.....	45

P

Parade Drums.....	24, 25, 26, 27, 28
Parts, General.....	60, 61, 62, 63, 64
Pedals	42, 43
Pedal Beaters	45
Pedal Parts.....	60, 61
Practice Pads	50

R

Rain Covers	59
Ratchet	49

S

Scotch Bass Drums.....	24, 25, 26, 27
Slapstick	48
Sleigh Bells	48
Slings, All Types.....	49
Snare Drums.....	2, 3, 4, 5
Snares	64
Snare Strainers	63
Sock Pedal.....	46, 47
Song Whistle	48
Spurs	45
Stand, Bass Drum.....	10, 47
Stand, Bell Lyra.....	52
Stand, Cymbal	46
Stand, Hi-Hat.....	46, 47
Stand, Snare Drum.....	46, 47
Sticks, Bass Drum.....	39
Sticks, Snare Drum.....	38
Sticks, Tympani	39
Street Drums.....	24, 25, 26, 27, 28

T

Tambourines	48
Temple Blocks	51
Tenor Drums.....	24, 25, 26, 27
Tenor Drum Holder.....	28
Timbales	13
Tom Toms.....	11, 51
Tom Tom Holders.....	44, 45
Tom Tom Legs.....	11
Tone Block	48
Triangles	48
Tucking Tool	55
Tympani.....	30, 31, 32, 33
Tympani Trunks and Cover.....	34
Tympani Tuning Gauge.....	34

W

Wire Brushes	40
Whistle, Drum Major.....	53
Whistle, Siren	48
Wood Block	48
Wood Block Holders.....	49

LUDWIG EDUCATIONAL SERVICES

The Ludwig Co. has long been aware of the vital role it must play in music education. Wm. F. Ludwig pioneered the educational clinic program, giving the first industry sponsored clinic in 1927.

Today the Ludwig Educational Department is constantly striving to better serve the student and music educator by;

1 Supplying valuable teaching and educational aids free of charge.

2 Constantly adding to and revising the Ludwig line of teaching methods.

3 Personal assistance to students and directors.

4 Making available highly qualified clinicians for clinic and solo appearances upon completion of proper arrangements with the company.

The Ludwig Educational Department is ready and most willing to assist you with your percussion problems. Write for free materials and complete information on services available.



HOW TO ORDER Ludwig products are sold by authorized music dealers everywhere and are only available through these dealers. When ordering please give catalog number and complete information on size, color, finish, plating and any special instructions. Please give shipping instructions plainly.

Holder will be mounted unless otherwise specified. Most drums will be supplied with the new Ludwig PLAYON plastic heads unless otherwise specified. Accompany each order for special CUSTOM lacquer colors with sample of color desired. All special colors and models accepted only on a non-returnable and non-cancellation basis.

Ludwig DRUM CO.

1728 No. Damen Ave.
Chicago 47, Illinois
Telephone: ARmitage 6-3301





LUDWIG DRUM CO. 1728 No. Damen Ave.
Chicago 47, Illinois