

Ludwig[®]

CATALOG NUMBER **'75**



**WATERLOO MUSIC
COMPANY LIMITED**

1 REGINA N. 913 CARLING AVE.
WATERLOO • ONT. • OTTAWA

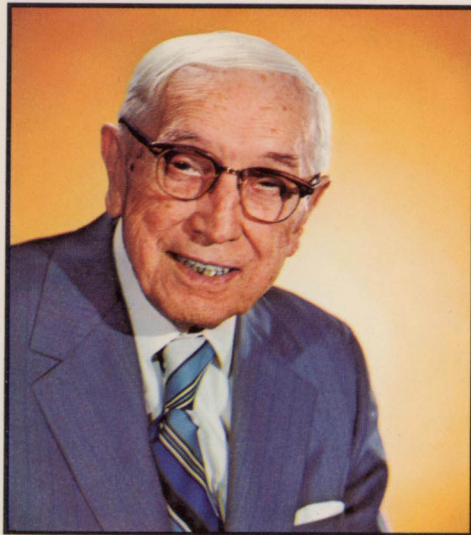

William F. Ludwig, Sr.
1879-1973

We dedicate this page to our founder, Wm. F. Ludwig, Sr. who, for 64 years, guided the destiny and development of our company.

Ludwig Industries was founded June 1st 1909, by Mr. Ludwig and his brother Theobald in a humble garage on Chicago's west side. Both were drummers with a mutual interest in improving drum products.

Their first product, a drum pedal, was successful from the start. The success of this venture paved the way for the development of the first all-metal snare drum made on a production basis in this country, pedal tuned timpani and hundreds of new and progressive drummer's instruments and accessories.

We, the associates and employees of Ludwig Industries, salute the Founder of the modern drum industry, Wm. F. Ludwig, Sr., and pledge our allegiance to his lofty ideals in the performance of our duties in this, our chosen work.

The Ludwig Family



William F. Ludwig, Jr.
President



Maggie Ludwig
Director

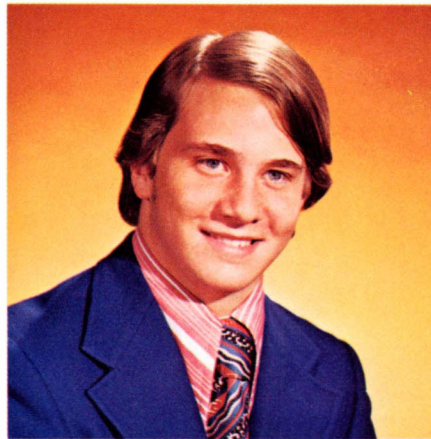

Bill Ludwig, III



Bettie Ludwig
Director

The name "Ludwig" designates more than a person, more than a brand of product, and even more than a company. It is a family heritage. . . an inheritance accrued over three generations of total dedication in serving the music profession. The name "Ludwig" has become synonymous with innovation, craftsmanship, product quality, and acknowledged superiority in the field of total percussion. The continuity of what has become to be a family

tradition, leadership, is assured by the President of Ludwig Industries - "The greatest sustaining factor," says Bill Ludwig, Jr., "is the pride of accomplishment which has been instilled in each member of our corporate family - - our skilled and loyal employees, our highly experienced department heads, our competent executive staff, our energetic company sales force, and the more than 3,500 enthusiastic Ludwig music dealers world wide".



FRANK K. PEPLER
Exec. Vice President

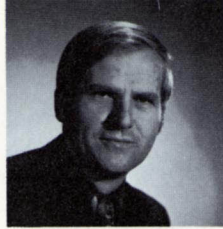

FRANK P. BAXPEHLER
Vice President
Advertising, Education
Ludwig International Ltd.



JOHN MAHONEY
Vice President, Finance



RICHARD J. RICHARDSON
Vice Pres., LaGrange Div.

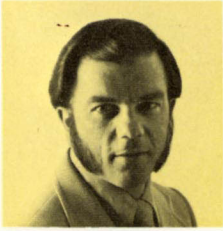

RICHARD GERLACH
Asst. Sales Manager

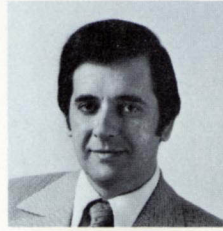

VERN J. BUSH
Advertising Manager



EARL MORTIMER
Credit Manager



LEON GLOZERIS
Western Sales



FRANK ARSENAULT
Educational Representative



DAVID SCHABELSKI
Eastern Sales



THEODORE L. DAYTZ
Asst. Mgr. Ludwig Intl. Ltd.



DARYL LOSEE
Customer Service



HENRY M. LARSON
North Pacific Sales

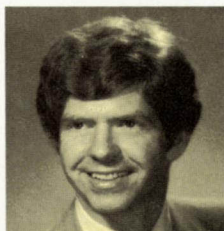

JIM PATTERSON
North West Sales

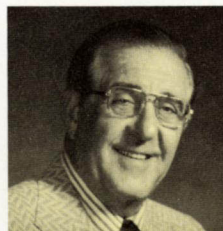

ROBERT SOUTHEY
Central Sales



LEO PALAS
North East Sales



RAY NELSON
North Atlantic Sales



WILLIAM H. FORD
Central Atlantic Sales



JACK GUENTHER
South Pacific Sales

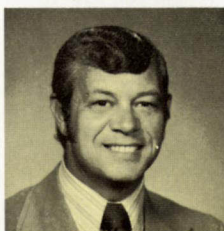

TED PENDLETON
West Central Sales



GEORGE HUMES
South West Sales



JIM ELKINS
South Sales



EDWARD C. HOLTZ
East Central Sales



NICK RAVINE
South Atlantic Sales



Ludwig's corporate family is joined together in the singular purpose of better serving the musical needs of you, the customer. Included are accomplished musicians, creative planners, skilled craftsmen, and a host of special talents all pledged to meeting both the continuing and the changing requirements of the music profession. When considering Ludwig products, consider the people behind the products... a family of individuals contributing their experience, their skills, and their ideas to our company motto: "Start at the top with Ludwig, and work your way up!"

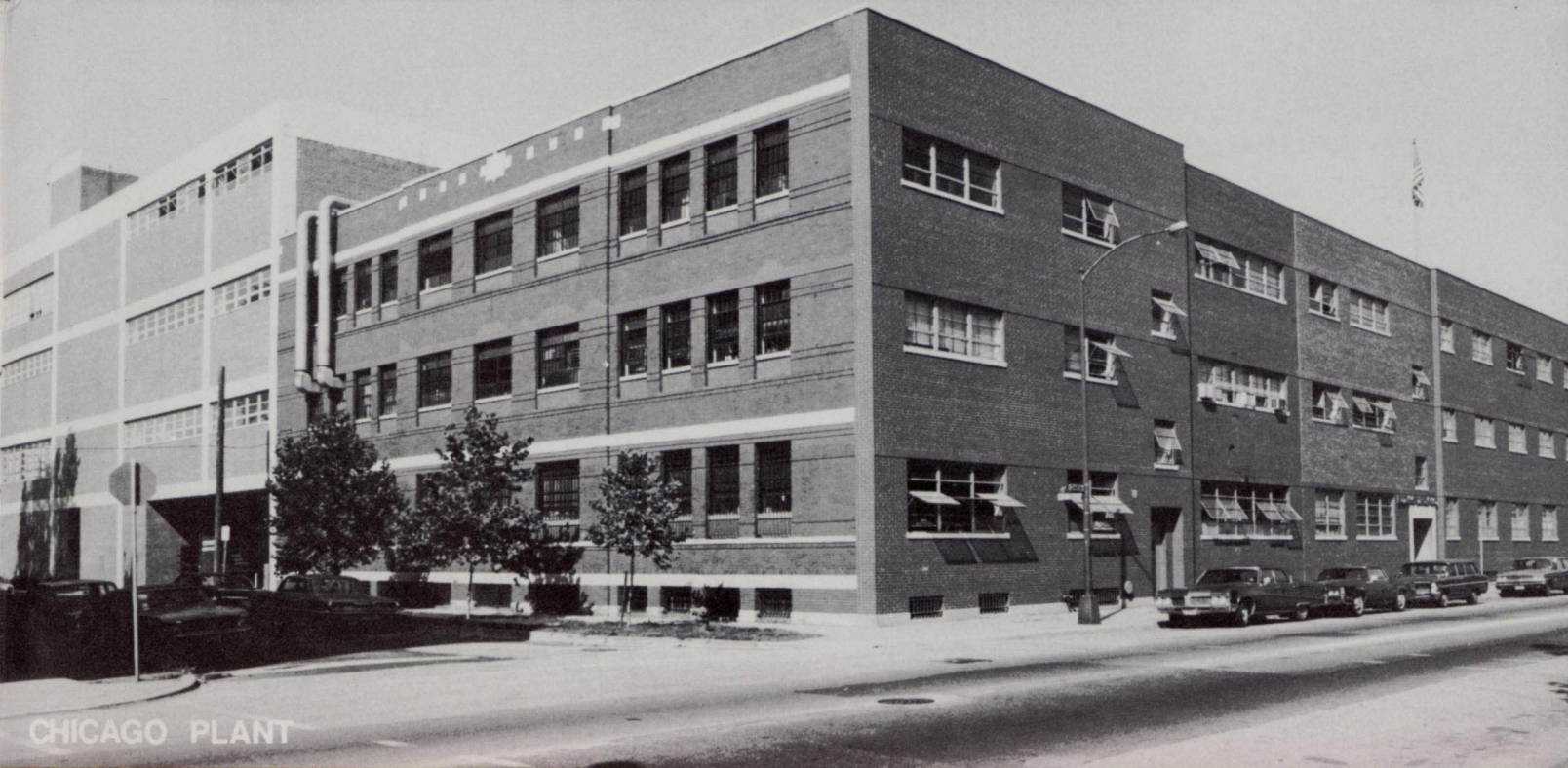

The main plant facilities of Ludwig Industries are second to none in the entire field of percussion. Imagine an area equal to four football fields, side by side, devoted exclusively to drums and percussion products! That's the equivalent of the Ludwig building complex located at 1728 North Damen Avenue, Chicago.

The original structure, a 5,000 square foot factory building, has grown to now encompass 197,000 square feet. The most recent expansion being an impressive four story 64,000 square foot addition allowing Ludwig to expand and adequately house the Engineering Department, the Educational Department, Purchasing Department, Research and Development, the Tool and Die Department and the drum case division. Moreover, the new building provides for much needed warehouse space to better service the needs of dealers and customers alike.

Today, not only is Ludwig the largest manufacturer of drums - - it is a corporation whose goal is set by the Ludwig family solely devoted to continued growth and leadership in Total Percussion.

Ludwig's LaGrange plant is the world's largest producer of mallet keyboard percussion instruments - - xylophones, marimbas, vibes, bells and orchestra chimes - - a division which has exhibited phenomenal and continued growth.

With the completion of its recently announced 10,000 square foot addition, the LaGrange complex now totaling 33,000 square feet, is truly a model of plant efficiency from the receiving dock to the shipping platform. All functions are now fully integrated and correlated within the expanded facilities - - engineering and design development, product evaluation material, production, quality control, warehouse and distribution.

To dealers, music instructors, band directors, professional performers and all interested customers, Ludwig Industries extends an open invitation to visit both the Chicago and LaGrange plant facilities when in the Chicago area. Personally escorted tours can easily be arranged on relatively short notice. Ludwig Industries, a family owned company, considers you the customer to be an important member of its family.





NO. 989KP

VISTALITE

THE LATEST SEE-THRU

Manufactured to the same exacting specifications as all Ludwig Classic Outfits nothing has been compromised to give the new VISTALITE Line superb tone quality and tonal projection. VISTALITE outfits are available in a full range of transparent, see-thru tints. And, to complete the transparent look, even the drum heads are water-clear "Weather Master" heads, exclusively Ludwig.

NO. 989KP – BIG BEAT OUTFIT (WITHOUT CYMBALS)
 Ludwig's Big Beat Outfit illustrates the crystal clear appeal of VISTALITE. Featured are the popular 401 Snare Drum in Vistalite (like No. 400), 14" x 22" Bass Drum, 8" x 12" and 9" x 13" Mounted Tom Toms, 16" x 16" Floor Tom Tom with Heavy Duty Stands and the Famous 201 Speed King Pedal.



NO. 2201 CLEAR



NO. 2205 YELLOW



NO. 2209 AMBER



NO. 993TP

LOOK JOINS THE FAMOUS LUDWIG DRUM LINE

NO. 993TP – PRO BEAT OUTFIT (WITHOUT CYMBALS)

Ludwig's Pro beat Outfit illustrates the transparent look of tinted Vistalite. Featured are the 401 Snare Drum in Vistalite (like No. 400), with 14" x 24" Bass Drum, 9" x 13" and 10" x 14" Mounted Tom Toms, 16" x 16" and 16" x 18" Floor Tom Toms, 201 Speed King Pedal and Heavy Duty Stands.

LUDWIG VISTALITE COLORS

Ludwig Vistalite Drums are available in all colors illustrated below. When ordering specify catalog No. of Drum or Drum Outfit and use the suffix (KP) for clear or (TP) for tinted shells. If outfits are desired with metal shell snare drum in place of Vistalite Snare Drum specify (KPM) for clear outfit or (TPM) for tinted outfits with metal shell snare drums.



NO. 2236 RED



NO. 2216 BLUE



NO. 2241 GREEN

FOR THE ULTIMATE IN TONAL COMBINATIONS—CONSIDER

OCTA-PLUS OR QUADRA-PLUS.....



Ludwig OCTA-PLUS OUTFIT

Inspired by both studio and rock drummers, the OCTA-PLUS offers the ultimate in tonal combinations. Featured are eight Melodic Tom Toms which can be tuned to play a complete melodic line. A special treatment applied to the larger size heads give the head more tonal center. This treatment also allows the drums to be tuned to a true pitch rather than a graduated pitch. Specially designed holders and stands offer complete height and angle adjustment for the tom toms. This outfit also includes the SUPRA-PHONIC "400" Snare Drum, twin 14" x 22" Bass Drums, 16" x 18" Floor Tom Tom, heavy duty ATLAS stands, 201 Speed King Pedals and the new Mid-Boy Hi-Hat.

No. 2001P—OCTA-PLUS OUTFIT, Choice of pearl finishes, WITHOUT CYMBALS.

No. 2002P—OCTA-PLUS OUTFIT, as above with 24" Bass Drums.

See Page No. 36 for complete listing of individual Melodic Tom Toms.

.....THE MELODIC TOM TOM OUTFITS



LUDWIG QUADRA-PLUS OUTFIT

Ludwig's QUADRA-PLUS is the answer to the modern "Rock" drummer's search for better projection over amplified sounds. Four Melodic Tom Toms, ranging in size from 13" to 16", offer a wide variety of tonal possibilities. Heavy duty ATLAS stands, 201 Speed King Pedal, Big Beat Hi-Hat, and new Sturdi-Lok tom tom stand and bass mounted holder are standard. Famous SUPRA-PHONIC "400" Snare Drum, 14" x 22" Bass Drum, and 16" x 18" Floor Tom Tom complete this unique outfit.

Sparkling Red Pearl Illustrated.

No. 2005P—QUADRA-PLUS OUTFIT. Choice of pearl finishes, WITHOUT CYMBALS.

No. 2006P—QUADRA-PLUS OUTFIT, as above with 24" Bass Drum.

now! *space age technology*
bring you the mighty

MACH 5



NAME PLATES

HEAVY HARDWARE

LUDWIG MACH 5 OUTFIT

In pace with the times the MACH-5 outfit combines visual elegance with super strength for the drummer who wants that extra edge in appearance and performance. Featured are the 5" x 14" Super-Sensitive Snare Drum, 14" x 22" Bass Drum, 8" x 12" and 9" x 13" Mounted Tom Toms, 16" x 16" Floor Tom Tom, BIG BEAT Hi-Hat stand, and the popular 201 Speed King Pedal. Heavy duty ATLAS snare stand and cymbal floor stands insure positive stability.

Red Silk Pearl Illustrated

Custom Name Plates available, see page 39.

No. 1005P—MACH-5 OUTFIT. Choice of pearl finishes WITHOUT CYMBALS.

No. 1006P—MACH-5 OUTFIT, as above with 24" Bass Drum.

*plus-Ludwig craftsmanship
and its companion outfit*

MACH 4

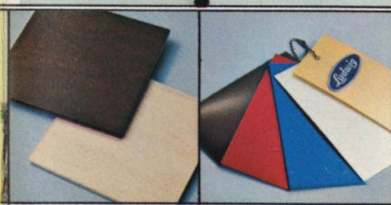

NEW CORTEX CHOICE OF COLORS

Ludwig MACH 4 OUTFIT

Until now, you couldn't buy this much customized luxury in a drum outfit. Built to unrivaled standards, this outfit features the 5" x 14" Super Sensitive Snare Drum, 14" x 22" Bass Drum, 9" x 13" Mounted Tom Tom, 16" x 16" Floor Tom Tom and BIG BEAT Hi-Hat stand. Famous 201 Speed King Pedal and glistening chrome ATLAS stands complete the set.

Blue Silk Pearl Illustrated.

Custom Name Plates available, see page 39.

No. 1000P—MACH-4 OUTFIT. Choice of pearl finishes WITHOUT CYMBALS.

No. 1003P—MACH-4 OUTFIT, as above with 24" Bass Drum.

LUDWIG...total outfits for the total drummer



LUDWIG DELUXE CLASSIC

Here is the drum outfit made to survive in the world of the professional drummer. The DELUXE CLASSIC is built to withstand the rough treatment of road travel—and the constant setting up and tearing down that comes with it. Featured is a 5" x 14" SUPRA-PHONIC "400" Snare Drum, 14" x 22" Bass Drum, 9" x 13" mounted Tom Tom, 16" x 16" Floor Tom Tom, and the 201 Speed King pedal. Also featured are Ludwig's extra heavy duty ATLAS Drum stand, BIG BEAT Hi-Hat Stand and two cymbal stands. All stands are of heavy gauge steel and triple chrome plated to ensure years of heavy duty service.

Oyster Black Pearl Illustrated

No. 990P—DELUXE CLASSIC OUTFIT, Choice of pearl finishes, WITHOUT CYMBALS.

No. 999P—DELUXE CLASSIC OUTFIT, as above with 24" Bass Drum.

No. 8570—Set of 4 Fibre Cases for 990 Outfit.



LUDWIG BIG BEAT OUTFIT

Laying down the "big beat" is what this outfit was made for. It's built super-strong to take the super-drive of today's "rock" drummer. Outfit features the 5" x 14" SUPRAPHONIC "400" all-metal snare drum, 14" x 22" Bass Drum, 8" x 12" and 9" x 13" mounted Tom Toms, 16" x 16" Floor Tom Tom and the 201 Speed King Pedal. Positive sturdiness and strength come from the heavy duty ATLAS Drum Stand, BIG BEAT Hi-Hat Stand and two Atlas cymbal stands. **NOTE:** Atlas cymbal stands are supplied with above outfit but not illustrated.

Psychedelic Red Pearl Illustrated

No. 989P—BIG BEAT OUTFIT, Choice of pearl finishes, WITHOUT CYMBALS.

No. 997P—BIG BEAT OUTFIT, as above with 24" Bass Drum

No. 8571—Set of 5 Fibre Cases for 989 Outfit.

LUDWIG

the outfit choice of discriminating drummers



LUDWIG SUPER CLASSIC

The popular SUPER CLASSIC outfit offers superb design and built-in quality to meet every exacting demand. Outfit features Ludwig's popular 5" x 14" SUPRA-PHONIC "400" Snare Drum, 14" x 22" Bass Drum, 9" x 13" mounted Tom Tom, 16" x 16" Floor Tom Tom. The finest in shell mount "positive locking" holders and Ludwig's new curved retracting spurs provide instant setup and years of dependable service. Modern flat base stands and the famous Ludwig Speed King pedal are standard. (Available with matching pearl snare drum at same price.)

White Marine Pearl Illustrated

No. 980P— SUPER CLASSIC OUTFIT, Choice of pearl finishes, WITHOUT CYMBALS.

No. 987P— SUPER CLASSIC OUTFIT, as above with 20" Bass drum.

No. 8570—Set of 4 Fibre Cases for 980 Outfit.



LUDWIG HOLLYWOOD

Ludwig's "Twin" tom tom outfits have really captured the imagination of today's modern "Rock" drummers. The HOLLYWOOD features the new all-angle retracting double tom tom holder that provides complete angle and height adjustment for mixed tom tom sizes. The popular SUPRA-PHONIC "400" 5" x 14" metal snare drum, 14" x 22" Bass Drum, 8" x 12" and 9" x 13" mounted Tom Toms, 16" x 16" Floor Tom Tom, the famous 201 Speed King pedal and curved retracting spurs are standard.

No. 983-1P—HOLLYWOOD OUTFIT, Choice of pearl finishes, WITHOUT CYMBALS.

No. 8571—Set of 5 Fibre Cases for 983 Outfit.

Sparkling Pink Champagne Pearl Illustrated

LUDWIG...the beat behind today's musical pace



LUDWIG PRO-BEAT

For the drummer who demands the absolute in his outfit, the PRO-BEAT offers a full range of sounds to provide the pulse for today's "aware" music. Outfit features the SUPRA-PHONIC "400" Snare Drum, 14" x 24" Bass Drum, 9" x 13" and 10" x 14" mounted Tom Toms, 16" x 16" and 16" x 18" Floor Tom Toms and 201 Speed King Pedal. Also featured are the ATLAS heavy-duty snare stand and cymbal floor stands, and BIG BEAT heavy-duty Hi-Hat Stand.

Oyster Blue Pearl Illustrated

No. 993P—PRO-BEAT OUTFIT, Choice of pearl finishes, WITHOUT CYMBALS.



NEW LUDWIG ROCK DUO

"Rock" drummers have really taken to the ROCK DUO outfit, finding it has just the right drum combination to deliver the solid drive demanded by today's new music. Twin 14" x 22" Bass Drums provide the bottom beat with the SUPRA-PHONIC "400" Snare Drum, 9" x 13" and 10" x 14" mounted Tom Toms, and 16" x 16" Floor Tom Tom delivering the complementary rhythms. With 2 Speed King 201 pedals, stands and accessories.

Sparkling Silver Pearl Illustrated

No. 985P— ROCK DUO OUTFIT, Choice of pearl finishes, WITHOUT CYMBALS.

No. 992P—ROCK DUO OUTFIT, as above with two 24" Bass Drums.



LUDWIG JAZZETTE

Offering the striking combination of high quality shells and sparkling chrome, the JAZZETTE also offers the combination of professional sound and dollar value. The famous SUPRA-PHONIC "400" snare drum sets the pace accompanied by a compact 12" x 18" Bass Drum, 8" x 12" and 14" x 14" Tom Toms and the durable 201 Speed King pedal. This is a four drum outfit that will well serve the most discriminating drummer. Available in choice of pearl finishes. All stands and hardware are triple chrome plated.

Mahogany Cortex Illustrated

No. 995P— JAZZETTE OUTFIT, Choice of pearl finishes, WITHOUT CYMBALS.

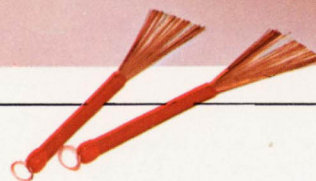

LUDWIG

SPEED KING PEDAL



- Twin Ball Bearings
- Twin Compression Springs
- Unbreakable Steel Toe Clamp
- Fast, Positive Tension Adjustment
- Non-Skid Rubber Base Mounting
- Exclusive Reversible Heel Plate

The "King" of all pedals, years of constant improvement have made the SPEED KING the most desirable pedal available anywhere today. Only the SPEED KING has precision die-cast stand, footboard, rocker shaft and heel plate. It is also the FIRST pedal to feature twin compression springs completely enclosed in the pedal posts. Protected dual ball bearings in a lifetime lubricant provide the fastest pedal action possible. Tension is adjustable and arched rocker shaft offers the leverage needed for ideal stability and balance. Rubber mat fitted to the footboard prevents skidding; heavy-duty linkage to withstand heavy foot pressure. Over 30 years of continual improvement have made the SPEED KING by far the "Professional" pedal.

No. 201 — SPEED KING
PEDAL

BASS DRUM PEDAL BEATERS

- No. 1285—Lambs Wool.
- No. 1286—Hard Felt.
- No. 1287—Solid Wood.



Exclusive reversible heel plate "flips" instantly to provide one or two piece footboard.



Springs compress rather than stretch, so each stroke of action gets stronger and faster.



Spring tension is adjustable with screwdriver from bottom of pedal.

LUDWIG

micromatic snare drum stand



The school snare drum stand features a sturdy wide angle base for maximum stability. Precision construction, instant height and angle adjustment and triple chrome plating make this stand ideally suited for school use.

**No. 1355-1—MICROMATIC
SCHOOL DRUM
STAND**
wide-angle
tripod base.

LUDWIG *quality pedals*

UNIVERSAL SPEEDMASTER

The "UNIVERSAL" SPEEDMASTER pedal is the result of many years of refinements and improvements of the original floor toe pedal, which was invented by Wm. F. Ludwig in 1909. Through the many years of modernization, the "UNIVERSAL" has become one of the most popular pedals at its price. Modern ball-bearing action along with a solid one-piece footboard, fully adjustable spring for desired tension, "free-floating" leather connecting strap, sturdy Ludwig construction and precision-balanced design make the "UNIVERSAL" SPEEDMASTER one of the finest pedals for the modern drummer.

**No. 252—UNIVERSAL
SPEEDMASTER.**



LUDWIG JUNIOR PEDAL

Here is fine quality performance at an economical price! The JUNIOR model is designed to provide fast, smooth, perfect action. Modern nylon bushings and precision-mounted one-piece cast footboard assure immediate pedal response; complete spring tension adjustment allows the drummer to enjoy desired, easy pedal action. Due to Ludwig's quality construction and design, the JUNIOR pedal offers long-lasting performance and satisfaction at a budget price.

**No. 207—LUDWIG JUNIOR
PEDAL.**



LUDWIG[®]

AIRLIFT ARTIST THRONE

Ludwig announces the latest advancement in stool design and comfort . . . The Airlift Artist Throne. More than just a drummers throne, the ease of adjustment, convenience of portability and extra comfort make this throne ideal for drummers, keyboard instrument players, combo musicians, string players, etc. Pneumatic height adjustment is controlled with finger tip ease. Large diameter padded seat rotates and is removable from extra chrome plated tubular steel base.

No. 1200 — AIRLIFT ARTIST THRONE.



- Large 14" Diameter
3½" Thick Cast Foam Seat.
- Fingertip Pneumatic
Height Adjustment.
- Heavy Duty Braced
Tubular Steel Legs.
- Extra Wide Base
For Added Stability.
- Self Leveling
Nylon Floor Guides.
- Folds Compactly Into
No. 8020W Trap Case.

FIBRE CASE FOR AIRLIFT THRONE

This heavy fibre case for the Airlift Throne is a must for the travelling musician.

No. 7154 — Fibre Case



LUDWIG *quality stands and stools*



1025-1

1123-1



1400

1363



1. Sure-grip heel Spur Lock
2. Positive DIRECT-PULL assembly
3. Floor leveler leg suspension

DURABLE "CLASSIC" LINE

The Ludwig "CLASSIC" line of fine quality stands and stool offers the drum world the greatest value available. Sturdy all steel construction with glistening chrome finish provides exceptional strength, long lasting durability and outstanding service. The 1123-1 "Direct Pull" hi-hat features floor leveler leg suspension, all metal bottom cymbal seat with built-in angle adjustment and the "sure-grip" Spur Lock heel assembly. The compact "Porto Seat" with oval, black vinyl covered seat offers dependable support and greater portability and compactness.

- No. 1400 — FLAT BASE CYMBAL STAND, folds to 22".
- No. 1123-1 — DIRECT PULL HI-HAT, folds to 20".
- No. 1363 — FLAT BASE SNARE DRUM STAND, folds to 20".
- No. 1025-1 — PORTO SEAT with Oval Black Vinyl Seat.
- No. 1401 — HEIGHT EXTENSION ROD for #1400 Stand (Not shown).



HEAVY DUTY "ATLAS" LINE

Ludwig's new ATLAS line of stands and stool are especially designed and built to withstand the rugged demands of today's drummers. The "heavy duty" construction can really take it yet each stand folds to compactly fit a standard trap case. The BIG BEAT Hi-Hat features DIRECT-PULL action with variable spring tension adjustment knob, both toe and heel spurs to hold the stand in place and height and angle adjustment of cymbals. The heavy duty ATLAS drum stand securely locks drum at any desired angle or height. The new ATLAS cymbal stand offers wide angle tripod base that can handle extremely large cymbals. The sturdy DRUM and TIMPANI stool has a round padded black vinyl covered seat.

- No. 1402 —ATLAS CYMBAL STAND.
- No. 1124 —ATLAS "BIG-BEAT" HI-HAT.
- No. 1364-5 —ATLAS DRUM STAND. (Dance Model).
- No. 1364-6 —ATLAS DRUM STAND (Concert Model) with 6" insert extension tube.
- No. 1369 —EXTENSION TUBE only for Atlas Drum and Cymbal Stands.
- No. 1026-2 —DRUM AND TIMPANI STOOL with Round Black Vinyl Seat.



1. Adjustable spring tension knob
2. Toe spur tip
3. Sure-grip heel Spur Lock

LUDWIG SUPER-SENSITIVE

with Acousti-Perfect shell design



Here is something *tonally different* in drums; finer than ever in sound and feel! The reason is the ACOUSTI-PERFECT seamless all-metal shell and especially crafted plastic heads, snares and new snare strainer developed by Ludwig.

Finest of drums, the SUPER-SENSITIVE has more exclusive features than any other. Snares extend across the entire surface of the snare head, providing full diameter snare vibration and sensitive response from the edge to the center of the drum. The new dual snare strainer provides for parallel snare release, operated by a single control lever. (Snares are kept under consistent, even tension when released away from the head.) The new snare strainer keeps the snares under even pressure-contact against the head . . . P-70.

The SUPER-SENSITIVE is the only drum available with eight different combinations of snare units, changeable in seconds for jazz, rock, symphonic band, orchestral or military drumming to meet the demands of the music being performed.

The beaded, perfectly round, seamless all-metal shell is triple chrome plated. Ten, self-aligning tension casings allow for maximum tonal transfer from batter to snare head and for minute tension adjustments.

Available in two popular sizes: 5" x 14" and 6½" x 14". A special screw-driver drum key is supplied with every drum. Each drum is mounted with specially designed plastic heads and 24-strand non-adjustable wire snares (triple swivel mounted), unless otherwise specified. A specially designed fibre carrying case or Dura-Hyde cover is available at additional cost.

No. 410 — 5" x 14" SUPER-SENSITIVE, **chrome.**

No. 411 — 6½" x 14" SUPER-SENSITIVE, **chrome.**

No. 413KP — 5" x 14" SUPER-SENSITIVE, **clear Vistalite.**

No. 413TP — 5" x 14" SUPER-SENSITIVE, **tinted Vistalite.**

No. 415KP — 6½" x 14" SUPER-SENSITIVE, **clear Vistalite.**

No. 415TP — 6½" x 14" SUPER-SENSITIVE, **tinted Vistalite.**

No. P-40 — SUPER-SENSITIVE Screw Driver Drum Key.

For complete listing of snare units refer to page 27.



A



B



C

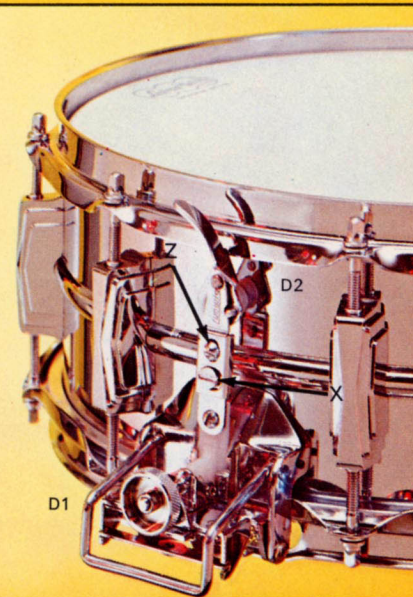

D1

D2

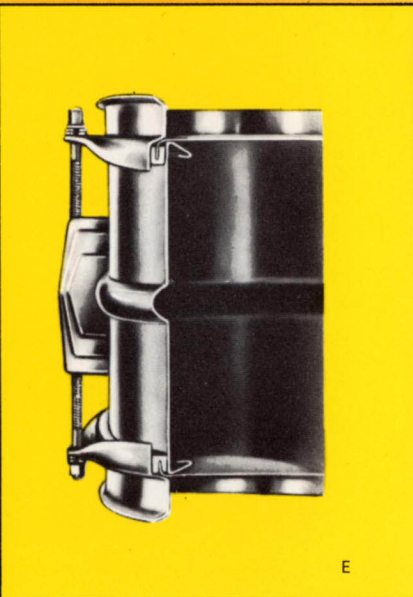

E

A QUICK CHANGE SNARE UNIT

You can change to your choice of eight different snare units in a matter of seconds. Each unit is complete with snares, swivel mounts and retainer ends. *For complete listing of snare units refer to page 27.*

B DUAL SNARE RELEASE WITH FULLY EXTENDED SNARES

Two complete mechanisms, operated by a single control lever, permit the drummer to release fully extended snares under uniform tension away from, and returned to, the snare head.

C INDIVIDUAL SNARE ADJUSTED UNITS

All eight snare units, with the exception of the 18 and 24-strand wire units, feature individual snare strand adjustment—assuring perfectly balanced snare action.

D1 DOUBLE SNARE TENSIONING—HORIZONTAL

All snare units are tensioned from both sides of the shell by the diamond knurled wheel screw located in each mechanism attached to the shell.

D2 DOUBLE SNARE TENSIONING—VERTICAL

Additional refined adjustments, for the desired amount of snare pressure-contact against the snare head, can be made with the height adjustment screw (Z) or the eccentric screw (X). These screws are located on the connecting link of each mechanism.

E ALL-METAL SEAMLESS SHELL

The only one-piece seamless shell, precision formed of heavy gauge metal with flanged edges and center bead for triple strength. (Only a seamless metal shell is perfectly round.)

F CASES AND COVERS FOR LUDWIG SUPER-SENSITIVE



No. 172-1—5" x 14" Special Dura-Hyde Cover for Super-Sensitive Drum

No. 173-1—6½" x 14" Special Dura-Hyde Cover for Super-Sensitive Drum

No. 7154—14" Square Vulcanized Fibre Case for Super-Sensitive Drum



LUDWIG

SUPRA-PHONIC 400

with Acousti-Perfect shell design



Ludwig's SUPRA-PHONIC 400 all-metal snare drums have long been the world's most popular drum, outselling all other makes and models.

Drummers get the six features they want most: Instant response over the entire drum head. Vivid tonal definition, each beat crisp and clear. Brilliant sound, choke-free at full volume. Full power without distortion. Full projection at all dynamics. Increased stick rebound for faster action with less effort.

The SUPRA-PHONIC all-metal snare drums are constructed with a one-piece ACOUSTI-PERFECT seamless shell, beaded in the center and flanged at the edges for triple strength.

Ten self-aligning tension casings provide extra fine head adjustment. The new P-85 snare strainer gives complete and instant snare control with full drop of snares. Triple-flanged hoops assure a solid rim shot every time.

You hear the difference, feel the difference in this superior drum. Try it! Offered in two popular sizes: 5" x 14" and 6½" x 14" and as standard equipment with all popular Ludwig outfits. Supplied with Ludwig WEATHER MASTER plastic heads and with 18 strand, wire snares.

No. 400 – 5" x 14" SUPRA-PHONIC SNARE DRUM, chrome.

No. 402 – 6½" x 14" SUPRA-PHONIC SNARE DRUM, chrome.

No. 401KP – 5" x 14" SUPRA-PHONIC SNARE DRUM, clear Vistalite.

No. 401TP – 5" x 14" SUPRA-PHONIC SNARE DRUM, tinted Vistalite.

No. 403KP – 6½" x 14" SUPRA-PHONIC SNARE DRUM, clear Vistalite.

No. 403TP – 6½" x 14" SUPRA-PHONIC SNARE DRUM, tinted Vistalite.

LUDWIG®

experience / imagination / craftsmanship



*ACROLITE
SNARE DRUM*

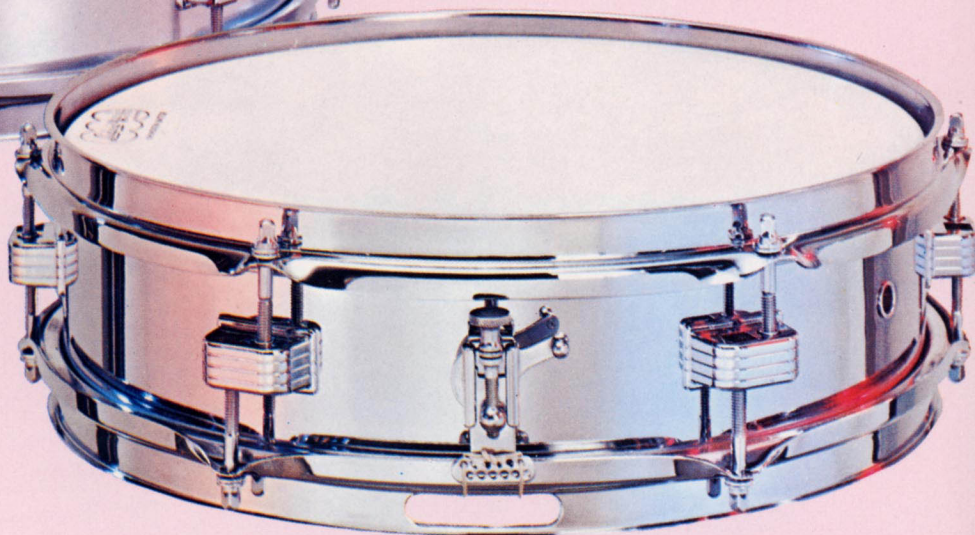

PICCOLO SNARE DRUM

ACROLITE SNARE DRUM

ACROLITE . . . lightens the drum, brightens the tone! Exciting advances in drum design and construction provide the first all-metal snare drum at a low price. Ludwig's wonder metal ACROLITE makes possible a lightweight drum with resonance and tone found only in more expensive models. The ACROLITE drum features Ludwig's ACOUSTI-PERFECT shell design, the famous one piece "beaded" metal shell, 8 self-aligning tension casings and triple-flanged hoops. Hoops and tension casings are bright finished. Supplied with the new Ludwig WEATHER MASTER plastic heads and 20 strand wire snares.

No. 404—5" x 14" ACROLITE SNARE DRUM.

PICCOLO SNARE DRUM

Presenting the PICCOLO snare drum, a new solo "soprano" percussion voice ideal for today's intricate, rhythmic patterns. The all-metal 3" x 13" shell produces the crisp sound demanded by so many of today's top recording percussionists. Special, separate tension casings allow extra sensitive tuning. Quick action "Pioneer" throw-off; triple-chrome hardware; plastic heads. A must for the truly serious drummer.

No. 405—3" x 13" PICCOLO SNARE DRUM.



SYMPHONIC MODEL



SCHOOL FESTIVAL MODEL



AUDITORIUM MODEL



PIONEER MODEL

SYMPHONIC MODEL

Designed for the full, traditional concert tone, the **SYMPHONIC** has a deep 6½" x 14" ACOUSTI-PERFECT shell. This, along with the positive CLASSIC throw-off and 18 strand wire snare unit make this model the most artistic band and concert drum available. All chrome hardware and plastic heads.

No. 902P—6½" x 14" Choice of pearl finishes

AUDITORIUM MODEL

Though moderately priced, the **AUDITORIUM** model delivers an amazingly true and rich concert tone. The shell features the exclusive ACOUSTI-PERFECT shell. Original triple-flanged hoops, P-85 snare throw-off and 8 self-aligning tension casings, all triple chrome finished. In pearl finishes, plastic heads.

No. 470P—6½" x 14" Choice of pearl finishes
No. 471P—6½" x 15" Choice of pearl finishes

Mahogany Cortex Illustrated

SCHOOL FESTIVAL MODEL

The **FESTIVAL** is a quality concert drum designed especially for the school band and orchestra. Sturdy shell with 16 self-aligning tension casings and hard-chrome finished hardware guarantee this as a drum that will last. In pearl finish, plastic heads.

No. 912P—6½" x 14" Choice of pearl finishes
No. 914P—6½" x 15" Choice of pearl finishes

PIONEER MODEL

Here is the leader in the low-priced field available in two popular sizes: 5" x 14" and 6½" x 14". The **PIONEER** features Ludwig's sturdy shell, six self-aligning tension casings, triple-flanged hoops and the P-85 throw-off. ACOUSTI-PERFECT shell design provides superior tone and response found in more expensive models. Here is true value in a student line instrument. Supplied with the new Ludwig WEATHER MASTER plastic heads and 12 strand wire snares.

No. 491P—5" x 14" Choice of Pearl finishes
No. 490P—6½" x 14" Choice of Pearl finishes.

Mahogany Cortex Illustrated

WHEN ORDERING REPLACEMENT SNARE UNITS PLEASE BE SURE TO SPECIFY DRUM DIAMETER.

HOW TO MEASURE YOUR SNARES WHEN ORDERING:



OLD STYLE SUPER SENSITIVE SNARE UNITS

For P-88 Strainer used on Drum Models 410, 411, 420, 422 and 1270 thru 1276, manufactured BEFORE 1969.

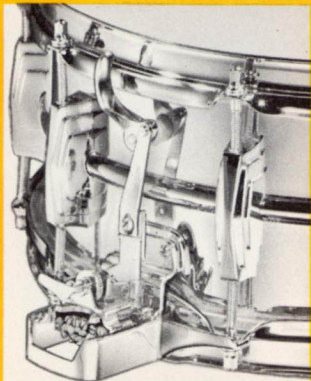

P-88 STRAINER

- No. 1212—10 Gut Snares, individually adjustable
- No. 1213—10 Gut/Wire Snares alternating, individually adjustable
- No. 1214—10 Wire Snares, individually adjustable
- No. 1215—18 Wire Snares, NOT individually adjustable

NEW STYLE SUPER SENSITIVE SNARE UNITS

For P-70 Strainer used on Drum Models 410, 411, 420, 422, and 1270 thru 1276, manufactured 1969 to PRESENT

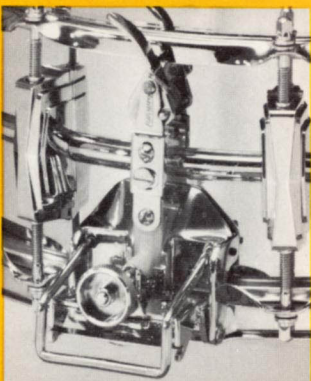

P-70 STRAINER

- No. 1232—24 Strand Wire Snares, NOT individually adjustable
- No. 1233—15 Strand Wire Snares, individually adjustable strands
- No. 1234—9 Wire 6 Gut Snares, individually adjustable strands
- No. 1235—15 Gut Snares, individually adjustable strands
- No. 1224—18 Strand Wire, swivel mounted, NOT individually adjustable
- No. 1225—10 Strand Wire, individually adjustable
- No. 1226—6 Strand Wire, 4 Gut, individually adjustable
- No. 1227—10 Strand Gut, individually adjustable

HIGH-TENSION SNARE UNITS

For High Tension Drums with P-87-1 Strainer and P-33 Snare Butt.

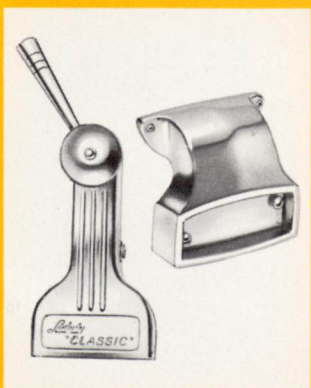

P-87-1 STRAINER and P-33 SNARE BUTT

- No. 1112—12 Gut Snares with adjusting plate, individually adjustable strands
- No. 1113—12 Wire-Gut Snares with adjusting plate, individually adjustable strands
- No. 1114—12 Wire Snares with adjusting plate, individually adjustable strands

GUT SNARES FOR P83 & P85 STRAINER.

- P-104 12 Strand, Light Gut.
- P-104A 12 Strand, Heavy Gut.
- Q Two Tone Wire-Gut. (Specify Size Needed)

LUDWIG FINE QUALITY PLASTIC AND METAL END SNARES

METAL END THIN WIRE SNARES

- AM—12½" for 13" dia. drum, regular metal end thin wire, 12 strand used with P81, P83 and P84 strainers.....
- BM—13½" for 14" dia. drum, regular metal end thin wire, 12 strand used with P83 and P84 strainers.....
- CM—14½" for 15" dia. drum, regular metal end thin wire, 12 strand used with P83 strainer

- NM—13½" for 14" dia. drum, regular metal end thin wire, 18 strand used with P83 strainer

METAL END HEAVY WIRE SNARES

- DM—13½" for 14" dia. drum, regular metal end heavy wire, 12 strand used with P83 strainer
- EM—14½" for 15" dia. drum, regular metal end heavy wire, 12 strand used with P83 strainer

- FM—15½" for 16" dia. drum, regular metal end heavy wire, 12 strand used with P83 strainer

METAL END NEW CLASSIC SHORT THIN WIRE SNARES

- GM—13½" for 13" dia. drum, metal end new Classic short thin wire, 18 strand used with P-87 strainer.....
- HM—14½" for 14" dia. drum, metal end new Classic short thin wire, 18 strand used with P-87 strainer.....

- JM—15½" for 15" dia. drum, metal end new Classic short thin wire, 18 strand used with P-87 strainer.....

METAL END OLD CLASSIC LONG THIN WIRE SNARES

- LM—16" for 14" dia. drum, metal end old Classic long thin wire, 18 strand used with P87 strainer.....

- MM—17" for 15" dia. drum, metal end old Classic long thin wire, 18 strand used with P-87 strainer.....

PLASTIC END THIN WIRE SNARES

- A—12½" for 13" dia. drum, regular plastic end thin wire, 12 strand used with P81, P83 and strainers.....
- B—13½" for 14" dia. drum, regular plastic end thin wire, 12 strand used with P83 and P84 strainers.....
- C—14½" for 15" dia. drum, regular plastic end thin wire, 12 strand used with P83 strainer.....

- N—13½" for 14" dia. drum, regular plastic end thin wire, 20 strand used with P83 strainer.....

PLASTIC END HEAVY WIRE SNARES

- D—13½" for 14" dia. drum, regular plastic end heavy wire, 12 strand used with P83 strainer
- E—14½" for 15" dia. drum, regular plastic end heavy wire, 12 strand used with P83 strainer..

- F—15½" for 16" dia. drum, regular plastic end heavy wire, 12 strand used with P83 strainer..

PLASTIC END NEW CLASSIC SHORT THIN WIRE SNARES

- G—13½" for 13" dia. drum, plastic end new Classic short thin wire, 18 strand used with P87 strainer.....
- H—14½" for 14" dia. drum, plastic end new Classic short thin wire, 18 strand used with P87 strainer.....

- J—15½" for 15" dia. drum, plastic end new Classic short thin wire, 18 strand used with P87 strainer.....

PLASTIC END OLD CLASSIC LONG THIN WIRE SNARES

- L—16" for 14" dia. drum, plastic end old Classic long thin wire, 18 strand used with P87 strainer.....

- M—17" for 15" dia. drum, plastic end old Classic long thin wire, 18 strand used with P87 strainer.....

NOTE: All snares listed for use with P-83 strainer will also accommodate the new Ludwig P-85 strainer.

MODERN SNARE DRUM QUARTET

Ludwig now offers four all-metal snare drums in four separate voicings as part of its Total Percussion Concept . . . a concept that makes every percussion section "performance perfect" and complete. The crisp, live solo "Soprano" voice of the 3" x 13" PICCOLO; the tonally different "Alto" and "Tenor" voices of the versatile 5" x 14" and 6½" x 14" SUPER-SENSITIVE drums for jazz, rock and symphonic performances; the "Baritone" voice of the 12" x 15" SUPER-SENSITIVE PARADE drum for marches, special effects and reinforcement of basic drum parts. Here are four snare drums essential for performing the music of yesterday, today and tomorrow!

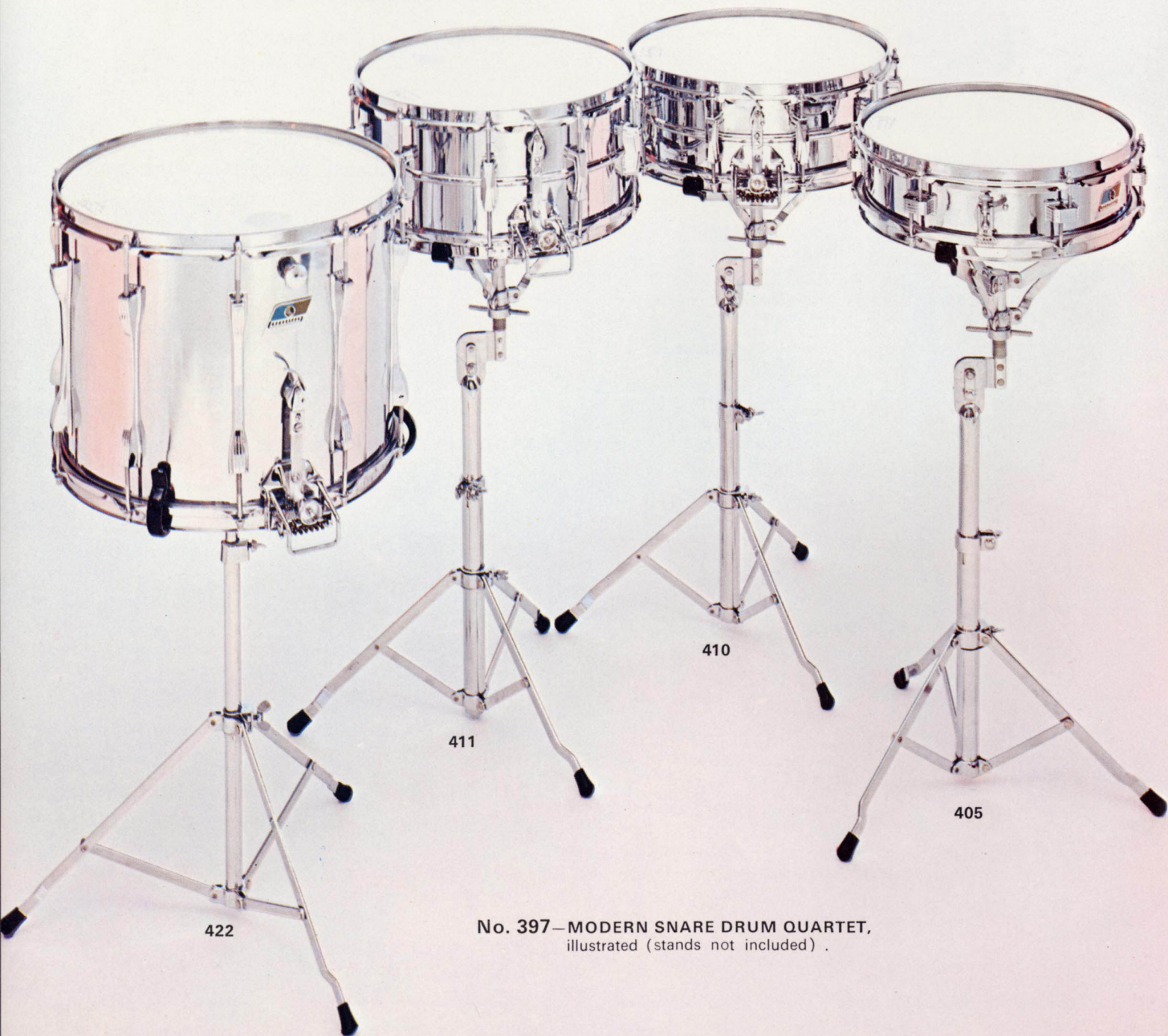

No. 397—MODERN SNARE DRUM QUARTET,
illustrated (stands not included) .

LUDWIG

...a modern concept in percussion education

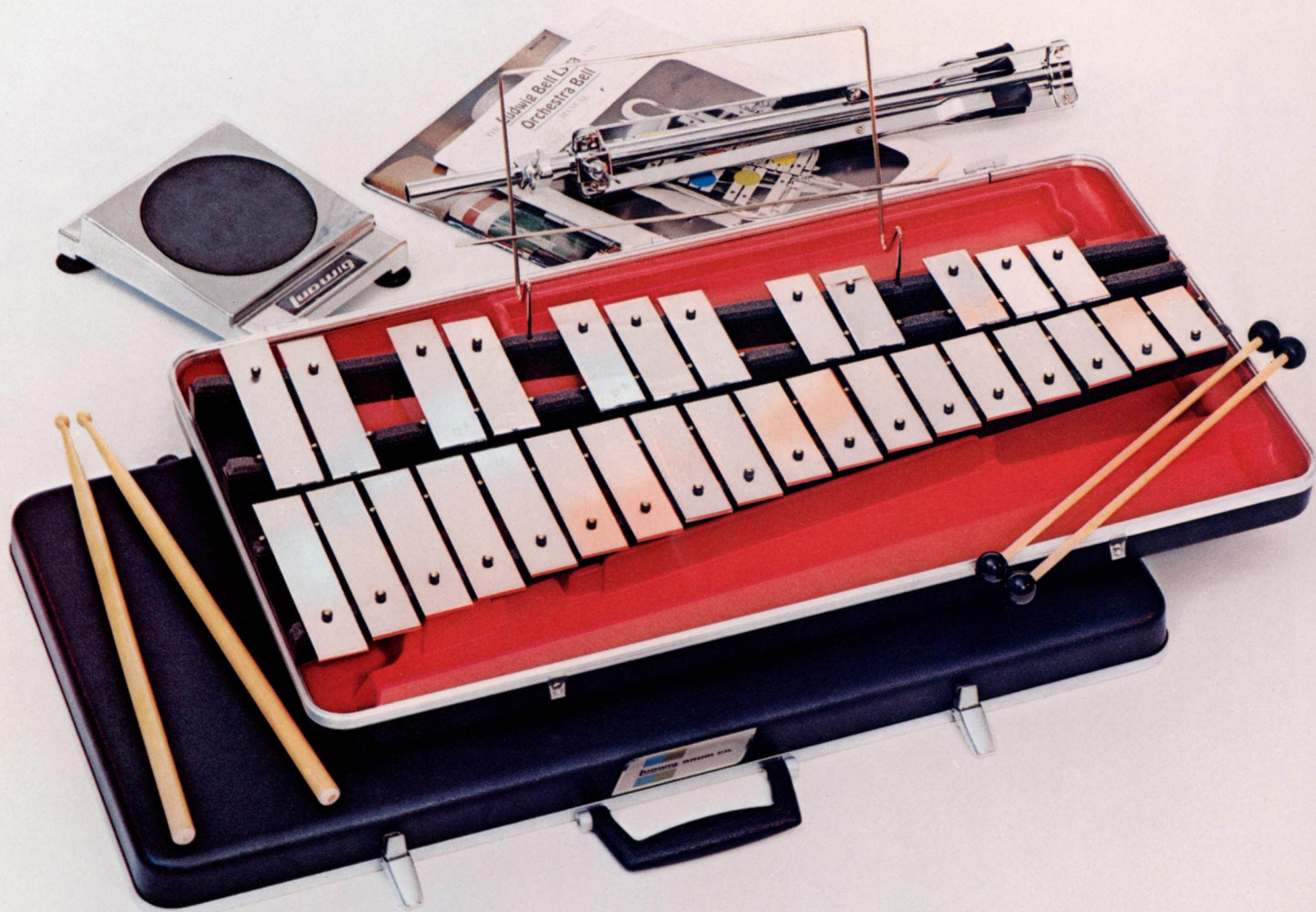

JUNIOR PERCUSSIONIST KIT

Ludwig's JUNIOR PERCUSSIONIST KIT is an entirely new approach to percussion education which introduces the beginning student to "total percussion" by developing melodic and rhythmic concepts, along with aural and visual concepts. Combining a 2½ octave set of chromatic steel bells with a heavy duty metal practice pad and stand, the JUNIOR PERCUSSIONIST KIT provides the means by which the student will learn manipulative and reading skills.

Carefully tuned to A-440, silver satin finished steel bells are mounted on a frame which rests upon a moulded insert in a handsome carrying case with removable lid. A pair of double end bell mallets and a pair of suitable drum sticks are included in the kit, along with selected study material.

The use of the Ludwig JUNIOR PERCUSSIONIST KIT will result in a more logical progress for a student to truly become a percussionist.

No. M-649 JUNIOR PERCUSSIONIST KIT, complete (G⁵-C⁸) with 355 Heavy Duty Metal Practice Pad, illustrated

No. M-650 JUNIOR PERCUSSIONIST KIT, with No. 359 8" Tunable Practice Pad

No. P-2473B—BELL STAND TOP INSERT for use with Pad Stand in Junior Percussionist Kit (not shown)

No. 1328—LIGHT WEIGHT BELL STAND complete (not shown).



LUDWIG

CONTOURA DRUM KITS



STANDARD CONTOURA KIT

The STANDARD CONTOURA KIT features the popular No. "404" 5" x 14" ACROLITE snare drum, the dependable Micromatic stand, the molded No. 8030 unlined Contoura case, Gladstone practice pad, a pair of sticks, and method book. Ideal for the beginning student drummer, the STANDARD CONTOURA KIT offers professional sound, dependability and economy.

No. 2444-1—STANDARD CONTOURA KIT,
complete.

No. 2450—STANDARD CONTOURA KIT, as above with
No. 354 pad in place of No. 351 pad.

No. 2459—STANDARD CONTOURA KIT, less pad.

PIONEER CONTOURA KIT

The PIONEER CONTOURA KIT offers real value to the beginning drummer and includes: the PIONEER model snare drum with 6 lugs, in your choice of pearl finishes, the Micromatic snare stand, No. 8030 unlined Contoura case, No. 354 Porto-Pad, sticks and method book.

No. 2458—PIONEER CONTOURA KIT,
complete.

No. 2451—PIONEER CONTOURA KIT, as above with
8 lug snare drum in place of 6 lug snare drum

LUDWIG "CONTOURA" DRUM KIT CASE

The seamless "CONTOURA" drum kit was developed and perfected by Ludwig Drum Co. to provide maximum protection for the drum and accessories. Molded of durable, high impact material, the light-weight "CONTOURA" is available in three interior finishes: unlined, blue felt lined or red plush lined. Drum fits comfortably into top of case; separate bottom compartment holds all accessories.

See page 102 for listing



SUPER DELUXE CONTOURA KIT

Ludwig combines the excellent qualities of the SUPRAPHONIC "400" 5" x 14" snare drum and the Micromatic stand with the deluxe red plush-lined "CONTOURA" molded case to offer the finest quality drum kit available. Light in portable weight and complete with a pair of suitable snare drum sticks, Gladstone practice pad and method book, the SUPER DELUXE CONTOURA KIT provides the student drummer with the finest available.

No. 2441-1—SUPER DELUXE CONTOURA KIT, complete.

DELUXE CONTOURA KIT

The DELUXE CONTOURA KIT features the all-metal ACROLITE 5" x 14" snare drum in a "CONTOURA" molded case, lined in royal-blue felt. The kit is complete with sturdy Micromatic stand, famous Gladstone practice pad, a suitable pair of sticks and method book—everything for the beginning student at a moderate price.

No. 2443-1—DELUXE CONTOURA KIT, complete.

LUDWIG *quality drum kits*



CADET CONCERT KIT

The CADET CONCERT KIT offers the beginning drummer economy and service in his first drum. Supplied with 5" x 14" ACROLITE snare drum, folding stand and sticks. All items fit compactly into handsome lightweight luggage type case for protection and easy carrying. The CADET CONCERT KIT is an outstanding value in the low price field.

No. 2461—CADET CONCERT KIT, complete



SPOTLIGHT CONCERT KIT

The SPOTLIGHT CONCERT KIT contains everything for the student drummer in a handsome lightweight fibre case. The 5" x 14" six rod concert snare drum features the new P-85 strainer and throw-off to offer the finest control on any snare drum in its price range. Available in a wide choice of pearl finishes, the snare drum with flat base stand, rubber practice pad, sticks and drum method fit compactly into the case for easy portability.

No. 2447—SPOTLIGHT CONCERT KIT, complete.



MASTER CONCERT KIT

The MASTER CONCERT KIT features the lightweight, all-metal 5" x 14" ACROLITE snare drum with the new P-85 snare strainer and throw-off. This quality snare drum, with one piece seamless beaded shell, offers the tonal quality normally found in much higher priced drums. Supplied complete with Micromatic stand, rubber practice pad, a pair of suitable sticks and method book . . . all protected in a special case for durability and long service.

No. 2448—MASTER CONCERT KIT,
complete.



JUNIOR MARCHING KIT

Here is the ideal marching kit for the young drummer just starting his studies. Complete kit includes 10" x 14" single tension parade drum in a choice of pearl finishes, sticks, sling and handsome fibre case for extra protection. Matched plastic heads and the P-85 snare throw-off make this drum a quality leader in the low-price field.

No. 2446—JUNIOR MARCHING KIT,
complete.

(Mahogany Cortex Illustrated.)

LUDWIG[®]

SMALL CONCERT PERCUSSION KIT

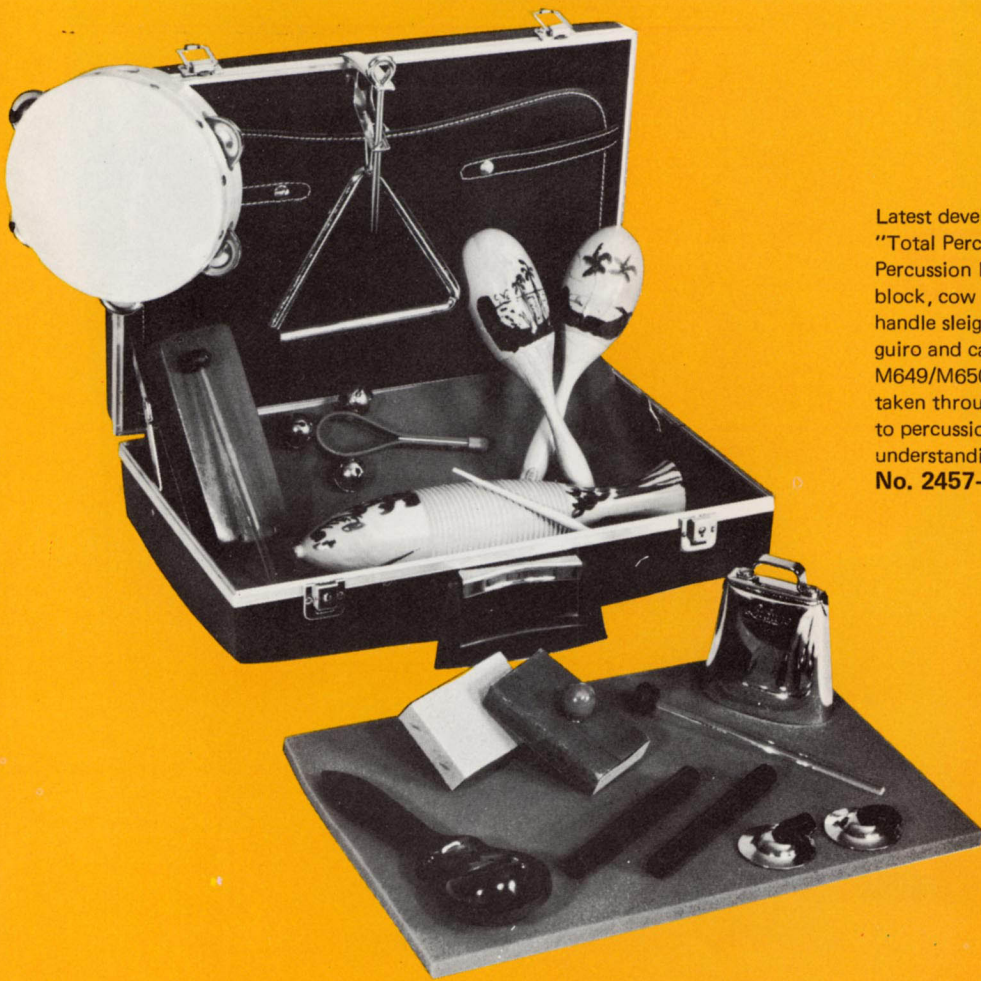

Latest development to support the concept of teaching "Total Percussion" is Ludwig's No. 2457—Small Concert Percussion Kit, complete with: two poly pads, wood block, cow bell, claves, tambourine, castanets, maracas, handle sleigh bells, triangle, finger cymbals, sand blocks, guiro and carrying case. Used concurrently with the M649/M650 Junior Percussionist Kit, the student can be taken through instructional techniques which are basic to percussion performance and relevant to musical understanding.

No. 2457—SMALL CONCERT PERCUSSION KIT.

4500 SOPRANO RECORDER

Molded of durable, impact-resistant material, this new recorder is available for individual home and group enjoyment, elementary educator use with classroom music, and band director use with students as a pre-band instrument. Supplied complete with Baroque Fingering Chart, Playing—Care—Assembly Instructions, and Carrying Case.

4510 SOPRANO RECORDER KIT

This kit contains the following:
4500 Recorder, complete
4520 "Recorder Book for Beginners"
4525 "Playing the Recorder" 12 inch LP recording, complete with Teacher's Guide.



LUDWIG[®] TOM TOMS

instruments of superior tone and resonance



No. 944P— 9" x 13"



No. 950P—16" x 16"
(No. 5022 Legs Included)

SUPER CLASSIC TOM TOMS

Super Classic tom toms are fashioned with the same care and attention to detail as all other Ludwig instruments.

Ludwig's original triple-flanged hoops and twin "Classic" tension casings are standard on all sizes. Specify your choice of pearl finish when ordering. All models supplied with triple chrome-plated hardware. All floor model tom toms are supplied with 17" legs mounted as standard equipment at no additional cost. (23" long legs available at no extra charge.)

Holders mounted on above models—extra. Specify your choice when ordering.

- No. 942P — 8" x 12" Choice of Pearl finishes.
- No. 944P — 9" x 13" Choice of Pearl finishes.
- No. 946P — 10" x 14" Choice of Pearl finishes.
- No. 947P — 12" x 15" Choice of Pearl finishes.
- No. 948P — 14" x 14" Choice of Pearl finishes, legs mounted.
- No. 950P — 16" x 16" Choice of Pearl finishes, legs mounted.
- No. 952P — 16" x 18" Choice of Pearl finishes, legs mounted.
- No. 954P — 18" x 20" Choice of Pearl finishes, legs mounted.

No. 5022 — Floor Tom Tom Legs complete with brackets (Not Shown) Specify 17" or 23" length.

CUSTOM TOM TOMS



OCTA-PLUS MELODIC TOM TOMS



CUSTOM TOM TOMS

LUDWIG CUSTOM DRUMS are available in this wide selection of sizes for the drummer who prefers to design his personal custom outfit or add to his existing outfit. Available in your choice of finishes.

- No. 1030P— 8" x 12" Tom Tom
- No. 1031P— 9" x 13" Tom Tom
- No. 1032P—10" x 14" Tom Tom
- No. 1033P—12" x 15" Tom Tom
- No. 1035P—14" x 14" Floor Tom Tom (legs mounted)
- No. 1036P—16" x 16" Floor Tom Tom (legs mounted)
- No. 1037P—16" x 18" Floor Tom Tom (legs mounted)
- No. 1045P—18" x 20" Floor Tom Tom (legs mounted)

No. 5022—Floor Tom Tom Legs complete with brackets (Not Shown) Specify 17" or 23" length.

Holders mounted on above models—extra. Specify your choice when ordering.

OCTA-PLUS MELODIC TOM TOMS

Engineered to meet the demands of today's music, Ludwig Melodic Tom Toms feature quality construction and dynamic projection. Specially treated heads and interior finish combine to produce uncomparable tone. When ordered with Sturdi-Lok stand or holder, mounting clips will be factory installed.

- No. 487P—5½" x 6" Melodic Tom Tom
- No. 488P—5½" x 8" Melodic Tom Tom
- No. 489P—6½" x 10" Melodic Tom Tom
- No. 461P— 8" x 12" Melodic Tom Tom
- No. 462P— 9" x 13" Melodic Tom Tom
- No. 463P—10" x 14" Melodic Tom Tom
- No. 464P—12" x 15" Melodic Tom Tom
- No. 465P—14" x 16" Melodic Tom Tom

For Holders and Stands refer to pages 38 and 39.

Note: For Matching Bass Drums and Floor Tom Toms refer to Classic Line listing pages 35 and 37.

LUDWIG[®] bass drums

LUDWIG CLASSIC

Here is the top quality line in bass drums featuring 20 large twin "Classic" self-aligning tension casings, matching form-fitting T-handles and double claw hooks providing even tension over entire head surface. Available in all popular sizes in your choice of finishes and in triple chrome-plated hardware. Pearl inlaid hoops and Model No. 1306 Bass Drum Spurs included on all models.

No. 920P – 14" x 20" Choice of Pearl finishes, with No. 1306 Spurs Mounted.

No. 922P – 14" x 22" Choice of Pearl finishes, with No. 1306 Spurs Mounted.

No. 924P – 14" x 24" Choice of Pearl finishes, with No. 1306 Spurs Mounted.

No. 926P – 14" x 26" Choice of Pearl finishes, with No. 1306 Spurs Mounted.



CUSTOM BASS DRUMS

LUDWIG CUSTOM Bass Drums represent the highest achievement in combining professional appearance with professional quality. They are available in a selection of sizes for the drummer who prefers to custom plan his personal outfit. Advanced "HIGH-TENSION" lug design relieves excessive stress on the shell. Hardware, including T-handles, HIGH-TENSION lugs and double claw hooks is super-finished in brilliant triple plated chrome. Available in your choice of finishes. All Bass Drums supplied with Model No. 1306 spurs.

No. 1040P – 14" x 20" Choice of Pearl finishes, with No. 1306 Spurs Mounted.

No. 1041P – 14" x 22" Choice of Pearl finishes, with No. 1306 Spurs Mounted.

No. 1042P – 14" x 24" Choice of Pearl finishes, with No. 1306 Spurs Mounted.

No. 1043P – 14" x 26" Choice of Pearl finishes, with No. 1306 Spurs Mounted.



TOM TOM SHELL MOUNT HOLDERS



No. 782-1—Single Tom Tom Holder, complete



No. 781-2—Double Tom Tom Holder, complete

Ludwig's shell mount tom tom holders feature die cast ratchet adjustments and splined angle bars, providing fine angle and positive locking adjustments. Both holders offer complete height and angle adjustments. The retracting 781-2 holder is mounted in the center of the bass drum for ideal playing position.

OCTA-PLUS HOLDERS



Ludwig's new STURDI-LOK Tom Tom Holder was specifically engineered for the single head Melodic Tom Toms. Designed to be interchangeable with the bass drum bracket used on the classic double tom tom holder, it features sturdy construction and positive ratchet type angle adjustment.

No. 779-1—STURDI-LOK Double Tom Tom Holder, complete with clip attachments

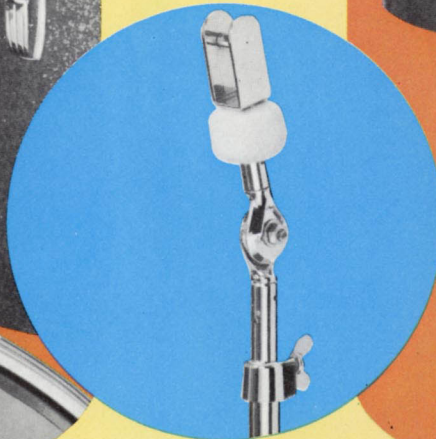

The STURDI-LOK Double Tom Tom Floor Stand features heavy duty construction to hold even the largest Melodic Tom Toms securely. Offering ideal height and angle adjustment, it meets the demands of today's drummers. Built for durability and compactness, the stand folds to fit a standard trap case.

No. 1340-1—STURDI-LOK Double Tom Tom Floor Stand, complete with clip attachments



BASS FELT STRIP

Recommended for use in outfit bass drums to control resonance. Sold individually for mounting on front and rear heads. Will fit all size dance model bass drums.
No. P-1804 FELT STRIP FOR BASS DRUM

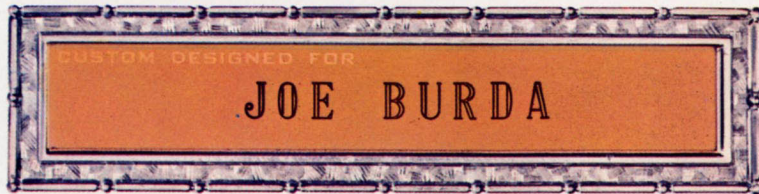

CUSTOM PERSONALIZED NAMEPLATE

Personalize your outfit with this gleaming name plate. Designed for mounting on your Bass Drum to add prestige and individuality.

No. 1029 CUSTOM NAME PLATE, specify name, Limit 18 Letters and Spaces.

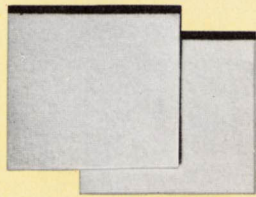

BASS DRUM IMPACT PAD

Ludwig's new "Impact Pads" are recommended for use on all outfit bass drums at beater ball contact area. Two pressure-sensitive adhesive cloth pads to a package.

No. 1288—2 Bass Drum Impact Pads.

BASS DRUM MUFFLER

The Ludwig bass drum muffler provides complete control of head ring. Set screw adjusts pressure tension on head, angle adjustment arm enables muffler to be placed in different positions.

No. 136—Adjustable Bass Drum Muffler.

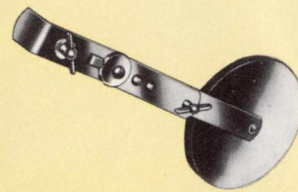

BASS DRUM ANCHOR

The Anchor prevents bass drum from "creeping" when being played. Reversible tips offer choice of rubber or steel points. Available in chrome only.

No. 1304-1—Bass Drum Anchor.

ROCKSTOP SPUR STOP

Designed to hold bass drum in place on slippery floors. Fits under spurs, anchors or hi-hat spur to eliminate "creep" during playing. Protects rugs and floors.

No. 1302—Rockstop Spur Stop, per pair.

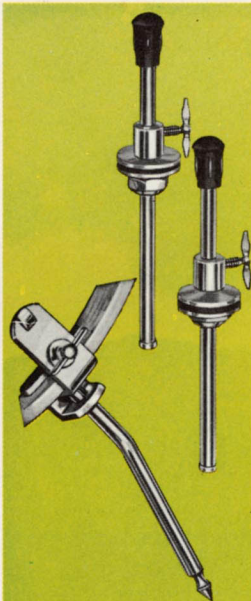

DISAPPEARING SPURS

Disappearing spurs are mounted on shell and disappear into bass drum when not in use. Provides fast set up.

No. 1303C—Disappearing Spurs, Pair, chrome.

GIANT SPURS

Ludwig Giant Spurs mount on bass drum counter hoop. Will fit all size bass drums. Available in chrome only.

No. 1301—Giant Spurs, pair.



NEW "SURE GRIP" CURVED RETRACTING SPURS

Ludwig now offers the most advanced design bass drum spur available that will stabilize and hold any bass drum in place. The curved retracting spurs angle forward for maximum holding power.

No. 1306—Curved Retracting Spurs, pair.



DOUBLE TOM TOM FLOOR STAND

Heavy duty construction, combined with positive ratchet adjustment provides complete angle adjustment with solid support. Stand includes mounting brackets for two Tom Toms. Heavy chrome-plated finish.

No. 1345-2 DOUBLE TOM TOM FLOOR STAND

LUDWIG *new marching percussion*



See pages 62 & 63 for Conga, Bongo and Timbale listings without stand to mount on No. 525 holder.



570

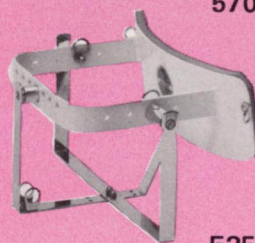

525



526

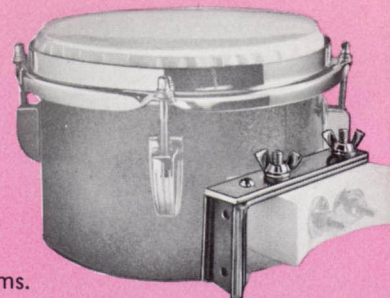

1338

NEW! LUDWIG TIMP-TOM TRIOS

The latest innovation in marching percussion, the timp-tom trio extends the color range of percussion on the march. Each drum in the trio is tunable. Each timp-tom unit is complete with carrying holder, balanced slings and a suitable pair of mallets. Fibre cases available at extra cost.

NEW! MULTI-MOUNT CARRYING HOLDER

Completely versatile, this carrying holder will accommodate drum diameters from 28" to 14". In addition, it will carry a set of twin congas and bongos (illustrated) or timbales and bongos. (See pages 62 & 63 for instrument listings without stand.) Especially crafted of sturdy metal and amply padded; complete with balanced sling assembly and clips.

No. 525—MULTI-MOUNT CARRYING HOLDER, complete

No. 526—DUAL/TRIPLE MOUNT CARRYING HOLDER, complete

No. 1338—METAL ATTACHMENT for Mounting No. 2358 Bongos to No. 525 Multi-Mount Carrying Holder (illustrated)

MOUNTING CLIPS FOR MULTI MOUNT HOLDERS (not shown)

No. P-1703A — For Metal Shell Drums.
No. P-1703B — For Wood Shell Drums.

NEW DUOS

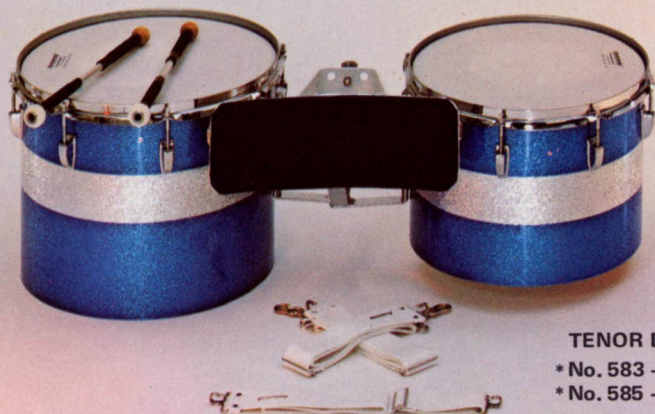

BASS DUO

Used to create the Timpani sound, Bass Duos add still another dimension to contemporary marching percussion. All Duos are supplied with No. 526 holder, balanced slings and mallets.

BASS DUO

- No. 584 - 12" Depth X 28" and 24" Diameter, complete. . C³ to B^{b3}.
- * No. 586 - 14" Depth X 26" and 22" Diameter, complete. . D³ to B³.

TENOR DUO

Used as pitched tenor drums, Tenor Duos can be played both rhythmically and rudimentally. All Tenor Duos are supplied complete with 526 holder, balanced slings and mallets.

TENOR DUO COMBINATIONS

- * No. 583 - 12" Depth X 15" Dia. and 10" Depth X 14" Dia., complete. . G⁴ to E^{b5}.
- * No. 585 - 10" Depth X 14" Dia. and 9" Depth X 13" Dia., complete. . C⁵ to F⁵.

MARCHING TIMP-TOM UNITS

TENOR TRIO COMBINATIONS

- * No. 570 - 10" Depth X 18", 16" and 14" Diameter, complete. . G^{b4} to E^{b5}.
- No. 571 - 12" Depth X 18", 16" and 14" Diameter, complete. . E⁴ to D^{b5}.
- No. 572 - 12" Depth X 20", 18" and 16" Diameter, complete. . D^{b4} to B^{b4}.
- No. 573 - 14" Depth X 20", 18" and 16" Diameter, complete. . B³ to A^{b4}.

BARITONE TRIO COMBINATIONS

- No. 574 - 12" Depth X 22", 20" and 18" Diameter, complete. . B^{b3} to G⁴.
- No. 575 - 14" Depth X 22", 20" and 18" Diameter, complete. . A^{b3} to F⁴.
- No. 576 - 12" Depth X 24", 22" and 20" Diameter, complete. . G³ to E⁴.
- * No. 577 - 14" Depth X 24", 22" and 20" Diameter, complete. . F³ to D⁴.
- No. 578 - 16" Depth X 24", 22" and 20" Diameter, complete. . E^{b3} to C⁴.

BASS TRIO COMBINATIONS

- * No. 579 - 14" Depth X 26", 24" and 22" Diameter, complete. . D³ to B³.
- No. 580 - 16" Depth X 26", 24" and 22" Diameter, complete. . C³ to A³.
- * No. 581 - 14" Depth X 28", 26" and 24" Diameter, complete. . B² to A^{b3}.
- No. 582 - 16" Depth X 28", 26" and 24" Diameter, complete. . A² to G^{b3}.

NOTE: Ludwig Trios and Duos are available in your choice of pearl and multi sparkle pearl finishes. Marching combinations listed above with asterisk (*) are also available in Stainless Steel.

SUGGESTED PLAYING RANGES FOR EACH TIMP-TOM

9" x 13" - E ⁵ to G ⁵	16" x 20" - A ³ to C ⁴
10" x 14" - C ⁵ to E ^{b5}	12" x 22" - B ^{b3} to D ^{b4}
12" x 14" - B ^{b4} to D ^{b5}	14" x 22" - A ^{b3} to B ³
12" x 15" - G ⁴ to B ⁴	16" x 22" - G ^{b3} to A ³
10" x 16" - A ⁴ to C ⁵	12" x 24" - G ³ to B ^{b3}
12" x 16" - G ⁴ to B ^{b4}	14" x 24" - F ³ to A ^{b3}
14" x 16" - F ⁴ to A ^{b4}	16" x 24" - E ^{b3} to G ^{b3}
10" x 18" - G ^{b4} to A ⁴	14" x 26" - D ³ to F ³
12" x 18" - E ⁴ to G ⁴	16" x 26" - C ³ to E ^{b3}
14" x 18" - D ⁴ to F ⁴	12" x 28" - G ² to B ²
12" x 20" - D ^{b4} to E ⁴	14" x 28" - B ² to D ³
14" x 20" - B ³ to D ⁴	16" x 28" - A ² to C ³

FIBRE CASES FOR TIMP-TOM UNITS (Drums only)

- No. 6893 - for 570 and 571.
- No. 6890 - for 572 and 573.
- No. 6991 - for 574 and 575.
- No. 8680 - for 576, 577 and 578.
- No. 8681 - for 579 and 580.
- No. 8682 - for 581 and 582.
- No. 6671 & 6470 - for 583.
- No. 6470 & 8362 - for 584.
- No. 6470 - for 585.
- No. 8681 - for 586.

MULTI-SPARKLE PATTERNS

Multi Sparkle finishes are available in the following patterns only. Specify your choice of colors. (See Examples.)

PATTERN I

Specify outer color first Ex: Sparkling Blue with Sparkling Silver center stripe.



PATTERN II

Specify outer color first. Ex: Sparkling Blue with Sparkling Gold border stripes and Sparkling Red center stripe.





MARCHING TIMPANI

- No. 1860 – 20" TIMPANI, aluminum kettle, range F³ to D⁴
- No. 1871 – 23" TIMPANI, fiberglass kettle, range D³ to B³
- No. 1872 – 26" TIMPANI, fiberglass kettle, range B² to G³
- No. 1873 – 29" TIMPANI, fiberglass kettle, range F² to D³

Note: All marching timpani are supplied in Satin Copper finish.

Ludwig's lightweight Marching Machine Timpani provide an additional dimension to the drum line. The kettles are completely portable. Supplied with tuning gauges and tuning handles for instantaneous adjustment, retracting legs, carrying slings, leg rest and a pair of suitable mallets.

RECOMMENDED MALLETS FOR MARCHING TIMPANI

- No. 343. For 20", Hard Felt
- No. 342. For 23", Med. Hard Felt
- No. 346. For 26", Med. Soft Felt
- No. 347. For 29", Soft Felt



MARCHING TIMPANI (legs retracted)
NOTE: Legs on 20" model do not retract but can be removed.



LUDWIG presents striking advances in marching percussion bringing exciting clarity and brilliance to parade drums. The new SUPER-SENSITIVE P-70 snare strainer has been incorporated in this line of parade drums providing effortless, undistorted, choke-free response heretofore found only in the finest concert drums. The new SUPER-SENSITIVE incorporates these exclusive Ludwig features: 10 high-tension lugs, ACOUSTI-PERFECT shell design, triple flanged hoops and your choice of 4 different snare combinations which can be changed in less than a minute. Here is an instrument that is the ultimate in the maker's art.

Supplied with 15 strand individually adjustable wire snares, unless specified otherwise.

ANOTHER LUDWIG FIRST!

LEG RESTS MOUNTED AS STANDARD EQUIPMENT ON ALL PARADE DRUMS.

SUPER-SENSITIVE SNARE DRUMS WITH LEG REST MOUNTED

No. 1280P – 10" x 14" Choice of Pearl finishes.
No. 1282P – 12" x 15" Choice of Pearl finishes.

For complete listing of snare units refer to page 27.

SUPER-SENSITIVE TENOR DRUMS WITH LEG REST MOUNTED

No. 1260P – 12" x 15" Choice of Pearl finishes.
No. 1261P – 12" x 17" Choice of Pearl finishes.

SUPER-SENSITIVE BASS DRUMS

No. 1178P – 10" x 26" Choice of Pearl finishes.
No. 1179P – 10" x 28" Choice of Pearl finishes.
No. 1182P – 14" x 28" Choice of Pearl finishes.

NOTE: For additional bass drum sizes, refer to Page No. 49.



Sparkling Gold Pearl Illustrated

Sticks and slings included. Pearl inlaid counter hoops are standard on all bass drums. When ordering snare drum covers, add one extra inch in diameter for snare guard. Square fibre case available at extra cost, refer to page No. 101.



DUAL SNARE RELEASE WITH FULLY EXTENDED SNARES

A single control lever releases both sides of the snares simultaneously. The snares are moved away, and returned to the snare head under uniform tension. Snares extend across and beyond the entire diameter of the drum head providing a full free snare vibration.

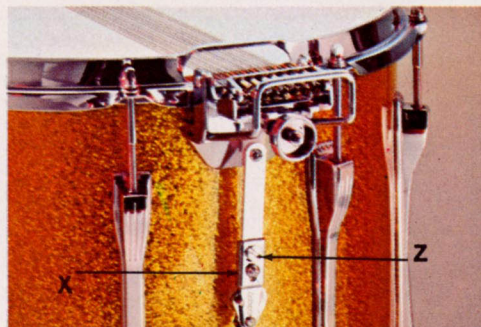

DOUBLE SNARE TENSIONING

All snare units are tensioned from both sides of the shell by the diamond knurled screw located in each mechanism attached to the shell. Additional adjustments, for the desired amount of snare pressure-contact, can be made with the height adjustment screw (X) or the eccentric screw (Z). These screws are located on the control link.

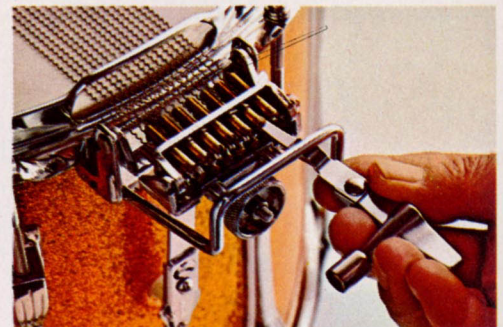

INDIVIDUAL SNARE ADJUSTMENT

All snare units feature individual snare strand adjustment, assuring perfectly balanced snare action, except the 18 and 24 strand units on swivel mounts. Special tuning key is equipped with swivel screw driver attachment which has been designed to adjust individual snares. To tighten snare, merely turn to the left, or to loosen snare, turn to the right.

LUDWIG®

ALL-METAL PARADE DRUMS

SUPER-SENSITIVE STAINLESS STEEL MODELS



No. 428 - 10" x 26"



No. 590 - 12" x 15"



No. 589 - 12" x 15"

Ludwig introduces another brand new concept in sound with all-new, all-metal SUPER-SENSITIVE parade drums. The glistening SUPER-SENSITIVE presents a striking "sound" advance in marching percussion that will set off your marching unit as something especially exciting, not only in looks, but in magnificent drum tone! The stainless steel all-metal shells, with the new P-70 SUPER-SENSITIVE strainer, are mirror bright and produce a clear, clean, crisp tone that you can appreciate only when you play them. If you are looking for something dramatically different in quality equipment, consider the new SUPER-SENSITIVE all-metal parade drums. Ten high-tension lugs provide the finest tuning possible on any drum. Sticks, beaters and slings included.

LEG RESTS MOUNTED AS STANDARD EQUIPMENT ON ALL PARADE DRUMS.

SUPER SENSITIVE SNARE DRUMS WITH LEG REST MOUNTED

No. 588 - 10" x 14" Stainless Steel.
No. 589 - 12" x 15" Stainless Steel.

SUPER SENSITIVE TENOR DRUM WITH LEG REST MOUNTED

No. 590 - 12" x 15" Stainless Steel.

SUPER SENSITIVE BASS DRUMS

No. 428 - 10" x 26" Stainless Steel.
No. 426 - 14" x 22" Stainless Steel.
No. 423 - 14" x 24" Stainless Steel.
No. 427 - 14" x 26" Stainless Steel.
No. 429 - 14" x 28" Stainless Steel.

NOTE:

If not specified, 15 strand individually adjustable wire snare will be supplied on all Super Sensitive Snare Drums. Refer to Page 27 for complete listing of snare units.

HIGH-TENSION STAINLESS STEEL MODELS



No. 593 - 12" x 15"



No. 592 - 12" x 15"



No. 428 - 10" x 26"

The Ludwig all-metal HIGH-TENSION parade drum shells are stainless steel for a durable and lustrous finish. Quality constructed and designed to withstand the extremely high head tensioning demanded by today's modern marching bands and drum corps, the new HIGH-TENSION drums feature 8 self-aligning HIGH-TENSION lugs, all-metal ACOUSTI-PERFECT shell design and the popular Classic Strainer. The chrome-plated P-33 extended snare butt, with die-cast housing, permits individual adjustment of all snare strands. All parts are triple chrome-plated to give your marching unit the brightest, most modern look to date. Here is exceptional quality in both brilliant appearance and remarkable performance. Sticks, beaters and slings included.

LEG RESTS MOUNTED AS STANDARD EQUIPMENT ON ALL PARADE DRUMS.

HIGH TENSION SNARE DRUMS WITH LEG REST MOUNTED

No. 591 - 10" x 14" Stainless Steel.
No. 592 - 12" x 15" Stainless Steel.

HIGH TENSION TENOR DRUM WITH LEG REST MOUNTED

No. 593 - 12" x 15" Stainless Steel.

HIGH TENSION BASS DRUMS

No. 428 - 10" x 26" Stainless Steel.
No. 426 - 14" x 22" Stainless Steel.
No. 423 - 14" x 24" Stainless Steel.
No. 427 - 14" x 26" Stainless Steel.
No. 429 - 14" x 28" Stainless Steel.

NOTE:

If not specified, 12 strand individually adjustable wire snares will be supplied on all High Tension Snare Drums. Refer to Page 27 for complete listing of snare units.



No. 1182P – 14" x 28"

Ludwig's HIGH-TENSION parade drum line offers the finest in styling, tonal response and quality construction. Designed and built to take the extremely high head tensioning demanded by today's modern bands and drum corps, the line features 8 self-aligning lugs, new ACOUSTI-PERFECT shell designs, and the popular Classic Strainer. All drums are available in your choice of pearl or Multi-Sparkle* pearl finishes. Supplied with 12-strand individually adjustable wire snare, unless specified otherwise.



No. 1166P – 12" x 15"

No. 1175P – 12" x 15"

LEG RESTS MOUNTED AS STANDARD EQUIPMENT ON ALL PARADE DRUMS.

HIGH TENSION SNARE DRUMS WITH LEG REST MOUNTED.

No. 1174P – 10" x 14" Choice of Pearl finishes.
No. 1175P – 12" x 15" Choice of Pearl finishes.

For complete listing of snare units refer to page 27.

HIGH TENSION TENOR DRUMS WITH LEG REST MOUNTED

No. 1166P – 12" x 15" Choice of Pearl finishes.
No. 1168P – 12" x 17" Choice of Pearl finishes.

HIGH-TENSION BASS DRUMS

No. 1178P – 10" x 26" Choice of Pearl finishes.
No. 1179P – 10" x 28" Choice of Pearl finishes.
No. 1182P – 14" x 28" Choice of Pearl finishes.

NOTE: For additional bass drum sizes
refer to Page No. 49

Sticks and slings included. Pearl inlaid counter hoops are standard on all bass drums. When ordering snare drum covers, add one extra inch in diameter for snare guard. Square fibre case available at extra cost, refer to page No. 101.

SUPER CLASSIC PARADE DRUMS



No. 1015P – 12" x 15"



No. 1012P – 12" x 15"



No. 979P – 10" x 28"

Ludwig SUPER CLASSIC parade drums have long been the choice of the nation's leading musical organizations. The reasons . . . Ludwig's attention to detail in design, provides added value to this popular line with new ACOUSTI-PERFECT shell design. This exclusive feature provides a finer drum tone with more resonance and power.

Ludwig's shells are lightweight for easy carrying, yet are the strongest available. All models supplied with glistening triple chrome-plated hardware. Sticks, beaters and slings, included.

LEG RESTS MOUNTED AS STANDARD EQUIPMENT ON ALL PARADE DRUMS.

CLASSIC SNARE DRUMS WITH LEG REST MOUNTED

No. 1010P – 10" x 14" Choice of Pearl finishes.
No. 1012P – 12" x 15" Choice of Pearl finishes.

CLASSIC TENOR DRUMS WITH LEG REST MOUNTED

No. 1015P – 12" x 15" Choice of Pearl finishes.
No. 1016P – 12" x 17" Choice of Pearl finishes.

CLASSIC BASS DRUMS

No. 978P – 10" x 26" Choice of Pearl finishes.
No. 979P – 10" x 28" Choice of Pearl finishes.
No. 974P – 14" x 28" Choice of Pearl finishes.

NOTE: Gut snares, two tone wire gut snares and classic throw-off available at extra cost.

NOTE: For additional bass drum sizes, refer to Page No. 49.

Illustrated in Sparkling Blue Pearl

PARADE MASTER PARADE DRUMS



No. 3207P – 12" x 15"



No. 3206P – 12" x 15"



No. 3220P – 10" x 28"

The popular PARADE MASTER line of drums features the modern center mounted separate tension casings designed for full tension control of each head separately. Ludwig's exclusive ACOUSTI-PERFECT shell design provides a finer drum tone with extra resonance and power without distortion. Triple-flanged hoops, instant snare throw-off and matched heads add to the high quality of this line.

Parade Master models are available in your choice of pearl finishes. All models supplied with triple chrome-plated hardware. Sticks, slings and beaters included.

NOTE: Gut snares, two tone wire gut snares and classic throw-off available at extra cost.

LEG RESTS MOUNTED AS STANDARD EQUIPMENT ON ALL PARADE DRUMS.

PARADE MASTER SNARE DRUMS WITH LEG REST MOUNTED

No. 3205P – 10" x 14" Choice of Pearl finishes.
No. 3206P – 12" x 15" Choice of Pearl finishes.

PARADE MASTER TENOR DRUMS WITH LEG REST MOUNTED

No. 3207P – 12" x 15" Choice of Pearl finishes.
No. 3208P – 12" x 17" Choice of Pearl finishes.

PARADE MASTER SCOTCH BASS DRUMS

No. 3214P – 8" x 26" Choice of Pearl finishes.
No. 3218P – 10" x 26" Choice of Pearl finishes.
No. 3215P – 8" x 28" Choice of Pearl finishes.
No. 3220P – 10" x 28" Choice of Pearl finishes.

NOTE: For additional bass drum sizes, refer to Page No. 49.

Illustrated in Multi-Sparkle Silver and Blue Pearl

LUDWIG

experience/imagination/craftsmanship

LUDWIG HIGH-TENSION BASS DRUMS

Ludwig's HIGH-TENSION Bass Drum line has proven to be very successful with drum corps and marching bands. The drums provide a resonant voice that can dominate or blend, depending upon how they are played.

The HIGH-TENSION line features Ludwig's modern high-tension lug that relieves excessive stress on the shell. Key tension rods and double claw hooks provide even head tensioning.

Available in choice of pearl finishes with glistening chrome-plated hardware. Eye hooks are mounted; carrying sling is supplied with drum. Mounted with single ply heads; double ply heads are available upon request. Supplied with a pair of suitable beaters.

No. 1181P – 12" x 24" Choice of Pearl finishes.

No. 1186P – 14" x 22" Choice of Pearl finishes.

No. 1188P – 14" x 24" Choice of Pearl finishes.

No. 1180P – 14" x 26" Choice of Pearl finishes.

No. 1182P – 14" x 28" Choice of Pearl finishes.

No. 1187P – 14" x 30" Choice of Pearl finishes.

No. 1184P – 16" x 30" Choice of Pearl finishes.

No. 1185P – 16" x 32" Choice of Pearl finishes.

THIN LINE SCOTCH BASS DRUMS

Used for young age marching groups or as an intermediate voice between tenor and scotch bass drums, the THIN LINE Scotch Bass Drums provide marching units with the needed added dimension in sound color.

The THIN LINE features separate tension self-aligning casings, key tension rods and double claw hooks for even head tensioning. Equipped with eye hooks and supplied with carrying sling and a suitable pair of beaters. Mounted with single ply heads.

No. 3216P – 6" x 26" Choice of Pearl finishes.

No. 3217P – 6" x 28" Choice of Pearl finishes.



(Mahogany Cortex Illustrated)

PREP MODEL

Traditional Ludwig quality craftsmanship and the finest of materials are combined in producing the popular PREP MODEL parade drums. These superb marching models are designed for the beginning drummer at an economical price. Counterhoops are tensioned by six single tension key rods. Modern contour double claw hooks provide even head tension. Instant throw-off strainer offers finger-tip snare tension adjustment. Sticks and slings included.

Here is real value in a low price student line instrument. Available in Mahogany Cortex finish.

No. 3062P — 10" x 14" PREP MODEL Mahogany Cortex finish, chrome hardware.

No. 833P — 14" x 28" BASS DRUM Mahogany Cortex finish, chrome hardware. (not shown).



(Mahogany Cortex Illustrated)

CUB MODEL

The CUB MODEL is designed for use by youngsters of Grade School age and offers fine quality in an economy line. Six single tension key rods and contour double claw hooks provide even head tension. Single screw snare strainer allows full snare control. Sticks and slings included. Available in Mahogany Cortex finish.

No. 2440P — 9" x 13" CUB MODEL Mahogany Cortex finish, chrome hardware.

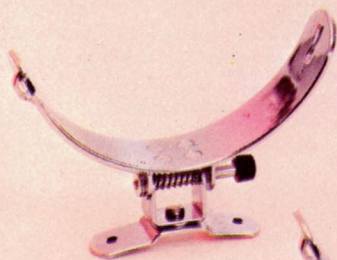

No. 478



No. 479

CLASSIC LEG RESTS

The Ludwig CLASSIC leg rest is designed to reduce leg fatigue and eliminates bruising knocks from the drum. The wide leg band is form fitting for comfortable carrying ease. Pin lock snaps leg rest in open or closed position.

Available in either rod mount or shell mount models. Easy to install on your present drum. Rod mount leg rest not recommended on Super Classic, High Tension or Super-Sensitive models. Designed for use with leather thongs if desired.

No. 478—Classic shell mount leg rest.

No. 479—Classic rod mount leg rest.

TENOR DRUM VERTI-HOLDER

The Ludwig originated VERTI-HOLDER places tenor drum in vertical position for playing ease and added flash. Holder folds against shell when not in use. Supplied in white lacquer only, complete with eye hooks, torso and waist slings.

No. 477—VERTI-HOLDER, complete.

No. 368—Verti-Holder Sling Assembly, complete.

Verti-Holder Sling Parts:

No. 350—Torso Sling.

No. 369—Waist Sling.

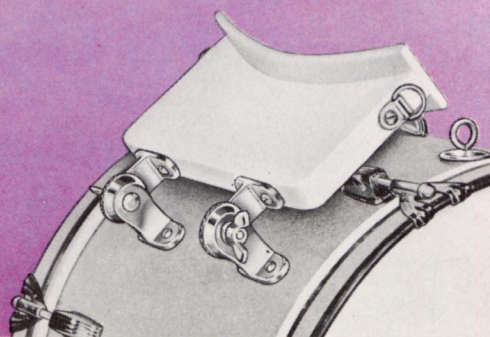
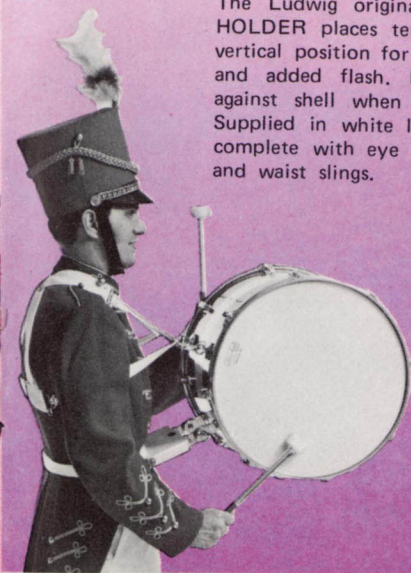

MULTI-ANGLE CARRYING HOOK

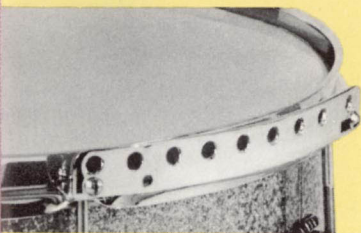

The adjustable carrying hook is one of Ludwig's latest marching accessories. The carrying hook is easily attached to the collar screw rods of any tenor or snare drum to provide a selection of sling hook-ups. This allows the drum to be carried at several desired angles to meet the physical requirements of the individual player.

No. 475 — Multi-Angle Carrying Hook.

MARCHING CONGAS, BONGOS, TIMBALES

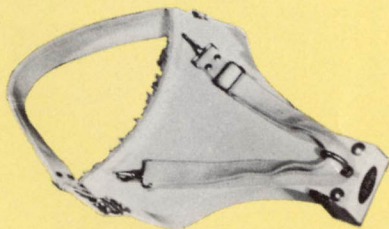

With this holder a set of Bongos or Timbales can be easily carried. Especially crafted of sturdy hardwood, amply padded; complete with hardware and balanced sling assembly.

No. 476 — Marching Holder For Bongos or Timbales complete.

DRUM AND TIMPANI SLINGS

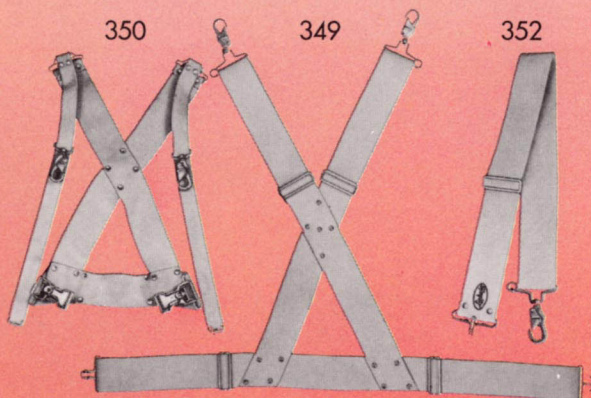

No. 349—Cadet Bass Drum Sling

No. 350—Standard Bass Drum Sling

No. 352—Parade Drum Sling

No. 367—Timp-Tom or Timpani Sling Assembly, complete

Timp-Tom and Timpani Sling Parts:

No. 352—Shoulder Sling for right side

No. 352L—Shoulder Sling for left side

No. 361—Waist Sling

No. 374—Black Web

No. 373—Black Web

No. 372—Black Web

No. 375—Black Web

No. 372—Black Web

No. 372L—Black Web

No. 376—Black Web

DRUM MAJOR SIGNAL BATONS

Ludwig's SIGNAL BATONS are crafted from select hickory, carefully sanded and finished to a high gloss. Ball and ferrule are chrome plated. Perfectly balanced!

Available in dark blue enamel with gold cord and tassel unless otherwise specified. Other colors at additional cost.

No. 116 —38" Signal Baton, standard.

No. 116S—38" Signal Baton, special.

No. 118 —44" Signal Baton, standard.

No. 118S—44" Signal Baton, special.

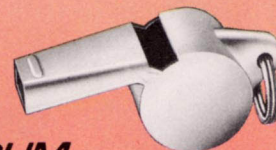

DRUM MAJOR WHISTLE

The finest Drum Major whistle made. The Acme "Thunderer" possesses great, piercing carrying power! Made in England.

No. 118W—ACME "THUNDERER" WHISTLE.

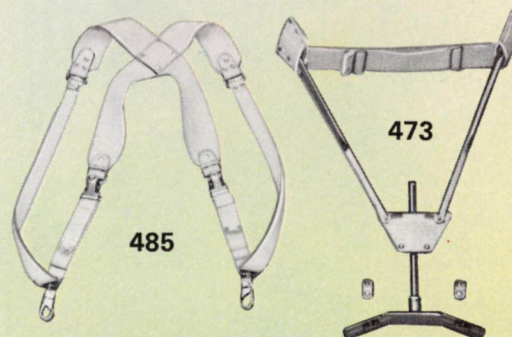

HI-STEPPER

Designed to hold a field snare or tenor drum out and away from the body torso, this carrier allows the drummer freedom of leg and arm movement. In addition, it provides maximum carrying ease and control of the instrument.

No. 473—HI-STEPPER, complete.

No. 485—Hi-Stepper, Sling Assembly, complete.

SWING FLAGS

Ludwig's SWING FLAGS are complete with flag, spring clip, steel shaft and rubber molded handle. Available in white only. Flag can be easily dyed, with any commercial color-fast dye by the purchaser.

No. 113—32" Swing Flag, complete.

No. 114—40" Swing Flag, complete.

No. 111—32" Shaft with handle, only.

No. 112—40" Shaft with handle, only.



Ludwig TOTAL PERCUSSION

TOTALLY MODERN IN SOUND and CONCEPT



LUDWIG . . . recognized by leading professional musicians, music educators and student percussionists as the world's standard in quality and dependability, continues to set new directions in TOTAL PERCUSSION. Through experience, imagination and craftsmanship, LUDWIG is always improving, always creating and always innovating to provide the music world with the finest in modern percussion instruments,

literature and educational concepts.

LUDWIG *means* TOTAL PERCUSSION . . . the most complete line of superior instruments, conceived, designed and built to meet the growing demands of contemporary composers and arrangers. No other percussion line offers so much, nor enjoys such universal use and acceptance.

LUDWIG ...presents new innovations
in pedal timpani



LUDWIG DRESDEN MODEL TIMPANI

NEW DRESDEN MODELS with DOUBLE RING KETTLE SUSPENSION

The new DRESDEN MODEL TIMPANI feature Ludwig's exclusive *double ring kettle suspension*, a free-floating, truly suspended kettle that offers greater resonance, projection and duration of tone at all dynamic levels. (See details of *double ring suspension* on pages 56 & 57)

Ludwig also introduces its new "profile" head design that extends the head collar beyond the edge of the kettle at just the right angle and distance for maximum definition of pitch fundamental. The DRESDEN MODEL features a precision pedal mechanism incorporating a system of reciprocal linkage which provides smooth and consistent foot action throughout the entire range. Unique "saw-tooth" clutch is engaged by side action clutch liner; locks pedal at any desired tone. Clutch lever may be shifted to either side of pedal footboard. Master tuning handle offers fractional tuning. WEATHER MASTER plastic heads, sticks and head protectors included.

POLISHED COPPER KETTLES

Sets:

No. 818—Set of 5: 20", 23", 26", 29", 32", DRESDEN TIMPANI.

No. 819—Set of 4: 23", 26", 29", 32", DRESDEN TIMPANI.

No. 876—Set of 2: 26" and 29" DRESDEN TIMPANI..

Individual Timpani:

No. 834—20" DRESDEN TIMPANI.

No. 869—23" DRESDEN TIMPANI.

No. 812—26" DRESDEN TIMPANI.

No. 813—29" DRESDEN TIMPANI.

No. 867—32" DRESDEN TIMPANI.

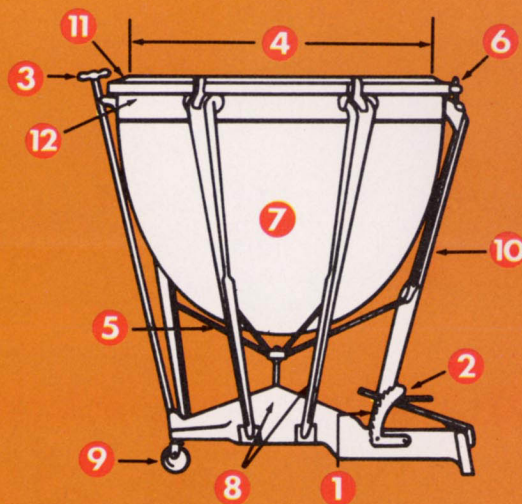

EXCLUSIVE FEATURES OF THE DRESDEN MODEL

1. Unique "Saw-Tooth" clutch locking pedal mechanism
2. Reversible clutch lever
3. Master tuning handle
4. 20", 23", 26", 29", 32" sizes standard
5. External tensioning
6. Eight key tension tuning rods
7. One-piece parabolic kettle, truly suspended
8. Lightweight aluminum struts and base
9. All-directional roller wheels with locks
10. Tension rods protected in support struts
11. New "Profile" head design
12. Double ring kettle suspension

FIBERGLASS KETTLES

Sets:

No. 1835—Set of 5: 20", 23", 26", 29", 32", DRESDEN TIMPANI*

No. 1836—Set of 4: 23", 26", 29", 32" DRESDEN TIMPANI

No. 1876—Set of 2: 26" and 29" DRESDEN TIMPANI.

All Timpani are priced with plastic heads.

* 20" Kettle is aluminum

Individual Timpani:

No. 1869—23" DRESDEN TIMPANI.

No. 1847—26" DRESDEN TIMPANI.

No. 1848—29" DRESDEN TIMPANI.

No. 1867—32" DRESDEN TIMPANI.

SATIN FINISH ALUMINUM KETTLE

No. 1853—20" DRESDEN TIMPANI.



LUDWIG

innovators and manufacturers
of pedal tuned timpani since 1912



NEW PROFESSIONAL SYMPHONIC MODELS with DOUBLE RING KETTLE SUSPENSION

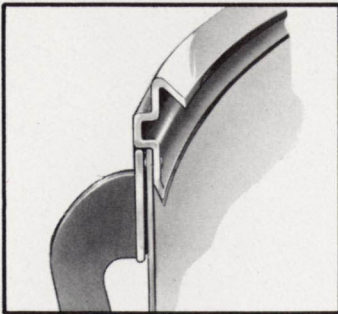

DOUBLE RING SUSPENSION

New "double ring" design completely suspends kettle in outer bracket ring.

LUDWIG: WORLD LEADER IN PEDAL TIMPANI, introduces its new PROFESSIONAL SYMPHONIC MODEL featuring *double ring kettle suspension*, a free floating suspended kettle that is entirely isolated from tuning mechanism. Kettle can be easily lifted out of outer suspension ring after removal of head.

The new PROFESSIONAL SYMPHONIC MODEL offers the greatest resonance, projection, and duration of tone at all dynamic levels available in any timpani today. New "profile" head design offers greater definition of fundamental pitch. Exclusive Ludwig *Balanced Action* pedal mechanism provides fast, effortless tuning required in today's contemporary music. Eight key tension

rods and suspension struts provide more accurate tuning. All mechanisms are placed on the outside of kettle assuring unbroken sound waves.

LUDWIG'S PROFESSIONAL SYMPHONIC MODELS are available in your choice of *polished copper* or *lightweight fiberglass* kettles. New *WEATHER MASTER* plastic heads, sticks and head protector included.

Compare feature for feature of this new Ludwig model with any other timpani available today . . . and most important, compare the full-bodied projected sound that only Ludwig offers.

All Timpani are priced with WEATHER MASTER plastic heads.

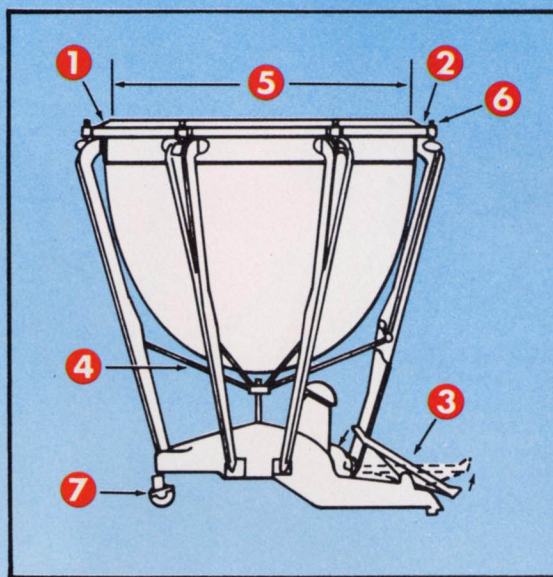

**EXCLUSIVE FEATURES of the
PROFESSIONAL SYMPHONIC MODEL**

- | | |
|------------------------------------|---|
| 1. NEW DOUBLE RING SUSPENSION | 5. LARGER KETTLE DIAMETERS FOR GREATER TONAL BODY |
| 2. PROFILE EXTENDED HEAD | 6. EIGHT KEY TENSION TUNING RODS |
| 3. BALANCED ACTION PEDAL MECHANISM | 7. ALL DIRECTIONAL ROLLER WHEELS |
| 4. EXTERNAL TENSION | |

For Tuning GAUGES see page 61.

POLISHED COPPER KETTLES

Sets:

No. 816—Set of 5: 20", 23", 26", 29", 32" PROFESSIONAL SYMPHONIC TIMPANI.

No. 817—Set of 4: 23", 26", 29", 32" PROFESSIONAL SYMPHONIC TIMPANI.

No. 880—Set of 2: 26" and 29" PROFESSIONAL SYMPHONIC TIMPANI.

Individual Timpani:

No. 835—20" PROFESSIONAL SYMPHONIC TIMPANI

No. 879—23" PROFESSIONAL SYMPHONIC TIMPANI.

No. 814—26" PROFESSIONAL SYMPHONIC TIMPANI.

No. 815—29" PROFESSIONAL SYMPHONIC TIMPANI.

No. 878—32" PROFESSIONAL SYMPHONIC TIMPANI.

FIBERGLASS KETTLES

Sets:

No. 1837—Set of 5: 20", 23", 26", 29", 32" PROFESSIONAL SYMPHONIC TIMPANI.

No. 1838—Set of 4: 23", 26", 29", 32" PROFESSIONAL SYMPHONIC TIMPANI.

No. 1880—Set of 2: 26" and 29" PROFESSIONAL SYMPHONIC TIMPANI.

Individual Timpani:

No. 1854—20" PROFESSIONAL SYMPHONIC TIMPANI. (Aluminum Kettle, Satin Finish)

No. 1879—23" PROFESSIONAL SYMPHONIC TIMPANI.

No. 1849—26" PROFESSIONAL SYMPHONIC TIMPANI.

No. 1850—29" PROFESSIONAL SYMPHONIC TIMPANI.

No. 1878—32" PROFESSIONAL SYMPHONIC TIMPANI.

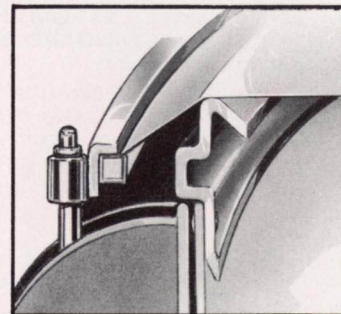

PROFILE COLLAR

New "profile collar" extends the head beyond the edge of kettle providing greater resonance and definition of pitch fundamental.

*20" Kettle is aluminum

LUDWIG ... total quality in timpani

In all musical history, no other timpani has enjoyed such great popularity as the Ludwig STANDARD SYMPHONY Model. Today, leading musical organizations the world over feature the incomparable tone and response of these fine instruments.

Ludwig's famous Balanced Action pedal provides instant, trouble-free tuning. Six sturdy suspension struts support the deep parabolic kettles offering maximum kettle resonance. All-directional roller wheels provide easy portability and lock instruments into playing position. Solid, seamless kettles are available in either mirror-smooth, polished copper or lightweight Fiberglass. Metal parts, including rods and hoops are chrome plated. WEATHER MASTER plastic heads, sticks and fibre head protectors are included.

Note: Key tension rods available in place of T-handle rods at no extra charge. Specify when ordering.



LUDWIG STANDARD SYMPHONY MODEL

Polished Copper Kettles

Sets:

No. 798—Set of 5: 20", 23", 26", 29", 32"
STANDARD SYMPHONY TIMPANI.

No. 799—Set of 4: 23", 26", 29", 32"
STANDARD SYMPHONY TIMPANI.

No. 891—Set of 2: 26" and 29"
STANDARD SYMPHONY TIMPANI.

Individual Timpani:

No. 836—20" STANDARD SYMPHONY TIMPANI.

No. 886—23" STANDARD SYMPHONY TIMPANI.

No. 795—26" STANDARD SYMPHONY TIMPANI.

No. 797—29" STANDARD SYMPHONY TIMPANI.

No. 887—30" STANDARD SYMPHONY TIMPANI.

No. 889—32" STANDARD SYMPHONY TIMPANI.

Fiberglass Kettles

Sets:

No. 1839—Set of 5: 20", 23", 26", 29", 32"
STANDARD SYMPHONY TIMPANI.

No. 1840—Set of 4: 23", 26", 29", 32"
STANDARD SYMPHONY TIMPANI.

No. 1890—Set of 2: 26" and 29"
STANDARD SYMPHONY TIMPANI.

Individual Timpani:

No. 1886—23" STANDARD SYMPHONY TIMPANI.

No. 1851—26" STANDARD SYMPHONY TIMPANI.

No. 1852—29" STANDARD SYMPHONY TIMPANI.

No. 1887—30" STANDARD SYMPHONY TIMPANI.

No. 1889—32" STANDARD SYMPHONY TIMPANI.

* 20" Kettle is aluminum

Satin Finish Aluminum Kettle

No. 1855—20" STANDARD SYMPHONY TIMPANI.

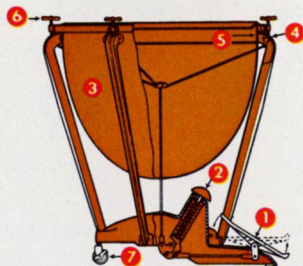

EXCLUSIVE FEATURES OF THE STANDARD SYMPHONY MODEL

1. Famous Ludwig Balanced Action pedal mechanism for fast, effortless tuning—located directly on the floor
2. Balanced Action control knob and spring eliminates need for ratchets or clutch
3. One-piece parabolic kettles for greater tone and resonance
4. Bell cranks and links are built into struts for maximum protection
5. Solid steel reinforcement band supports head tension, maintaining even head tone at all times
6. Small low-set tension handles are easy to reach, yet not in way of sticks when playing
7. All-directional roller wheels with built-in locks hold timpani in playing position

All Timpani are priced with plastic heads.

Long used by professional studio groups, university and school bands and orchestras, the UNIVERSAL Model was originally built by Wm. F. Ludwig, Sr. in 1919. It was designed and perfected for the discriminating professional, incorporating Mr. Ludwig's natural Balanced Action tuning mechanism, and has withstood the test of time and performance.

Tuning action is smooth and effortless, with floor level pedal which provides fast, accurate tone changes from seated or standing positions. Deep parabolic kettles assure superior tone and resonance throughout the entire range. All-directional roller wheels provide for quick position adjustment, yet lock in place when playing. Available with either polished copper or Fiberglass kettles; rods and hoops are chrome plated. WEATHER MASTER plastic heads, sticks and fibre head protectors included.



LUDWIG UNIVERSAL MODEL

Note: Key tension rods available in place of T-handle rods at no extra charge. Specify when ordering.

Polished Copper Kettles

Sets:

No. 933—Set of 5: 20", 23", 26", 29", 32"
UNIVERSAL TIMPANI.

No. 934—Set of 4: 23", 26", 29", 32"
UNIVERSAL TIMPANI.

No. 935—Set of 2: 26" and 29"
UNIVERSAL TIMPANI.

Individual Timpani:

No. 837—20" UNIVERSAL TIMPANI.

No. 894—23" UNIVERSAL TIMPANI.

No. 930—26" UNIVERSAL TIMPANI.

No. 932—29" UNIVERSAL TIMPANI.

No. 895—30" UNIVERSAL TIMPANI.

No. 864—32" UNIVERSAL TIMPANI.

Fiberglass Kettles

Sets:

No. 1893—Set of 5: 20", 23", 26", 29", 32"
UNIVERSAL TIMPANI.

No. 1894—Set of 4: 23", 26", 29", 32"
UNIVERSAL TIMPANI.

No. 1892—Set of 2: 26" and 29"
UNIVERSAL TIMPANI.

Individual Timpani:

No. 1897—23" UNIVERSAL TIMPANI.

No. 1881—26" UNIVERSAL TIMPANI.

No. 1882—29" UNIVERSAL TIMPANI.

No. 1898—30" UNIVERSAL TIMPANI.

No. 1863—32" UNIVERSAL TIMPANI.

* 20" Kettle is aluminum

Satin Finish Aluminum Kettle

No. 1856—20" UNIVERSAL TIMPANI.

All Timpani are priced with plastic heads.

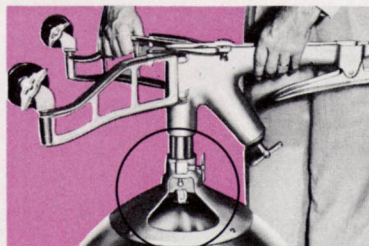

THE COMPLETELY PORTABLE TIMPANI

The UNIVERSAL Model features a detachable base, enabling kettle and pedal mechanism to be packed separately. When instruments are placed upside down, the ball and socket connection between main pull rod and pedal is readily accessible for fast set-up and dismantling. The wide-angle roller legs fold conveniently for packing.

LUDWIG

concert machine timpani

Ludwig combines quality with economy in offering the CONCERT MACHINE TIMPANI. Tuned by a single screw tuning mechanism, which is easily operated by a hand crank mounted near the playing surface, rapid tuning is achieved by merely turning the handle to the right to raise pitch or to the left to lower pitch. A full octave range is readily obtainable on each instrument. Legs telescope into kettle for easy packing.

Ludwig CONCERT MACHINE TIMPANI, with either copper or Fiberglass kettles, are designed for use in Junior High and Grade School organizations where budget and age of player are major factors. May be used as auxiliary instruments to an existing set of pedal timpani. WEATHER MASTER plastic heads, sticks and fibre head protectors included.

- Single Screw Tuning
- Full Octave Range
- Deep Parabolic Kettles
- Height and Angle Adjustment
- Removable Tuning Handle
- Chrome Hoops and Rods



Note: Key tension rods available in place of T-handle rods at no extra charge. Specify when ordering.



EXTRA PORTABILITY

Legs retract compactly into kettle for ease of transport and offer complete height and playing angle adjustment. Ideal for traveling organizations as well as the "pit" drummer.

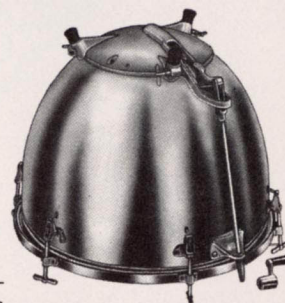

Note: 20" dia. kettle does not permit telescoping legs.

POLISHED COPPER KETTLES

Sets:

- No. 855—Set of 5: 20", 23", 26", 29", 32" MACHINE TIMPANI.
- No. 856—Set of 4: 23", 26", 29", 32" MACHINE TIMPANI.
- No. 854—Set of 2: 26" and 29" MACHINE TIMPANI.

Individual Timpani:

- No. 848—20" MACHINE TIMPANI.
- No. 872—23" MACHINE TIMPANI.
- No. 851—26" MACHINE TIMPANI.
- No. 853—29" MACHINE TIMPANI.
- No. 873—30" MACHINE TIMPANI.
- No. 865—32" MACHINE TIMPANI.

FIBERGLASS KETTLES

Sets:

- No. 1895—Set of 5: 20", 23", 26", 29", 32" MACHINE TIMPANI*
- No. 1896—Set of 4: 23", 26", 29", 32" MACHINE TIMPANI.
- No. 1870—Set of 2: 26" and 29" MACHINE TIMPANI.

Individual Timpani:

- No. 1874—23" MACHINE TIMPANI.
- No. 1883—26" MACHINE TIMPANI.
- No. 1884—29" MACHINE TIMPANI.
- No. 1875—30" MACHINE TIMPANI.
- No. 1866—32" MACHINE TIMPANI.

SATIN FINISH ALUMINUM KETTLE

- No. 1857—20" MACHINE TIMPANI.

All Timpani are priced with WEATHER MASTER plastic heads.
* 20" Kettle is aluminum



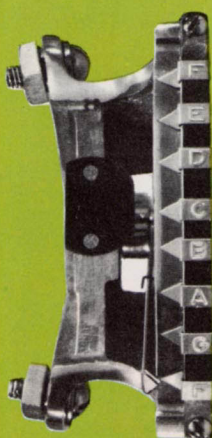
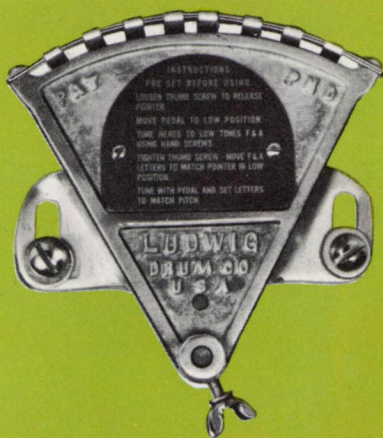

TIMPANI TUNING GAUGE

The exclusive Ludwig tuning gauge is essential in the performance of rapid changes in tuning and is ideal for use by the school and professional timpanist. This handy accessory measures the movement of the counterhoop and transfers this into accurate pitch readings by means of a pointer hand. The letters are movable on a sliding track since the gauge must be hand set before each use when using calfskin heads. They may be mounted on any make or model and complete instructions with drawing accompany each pair of gauges. They are extremely accurate when used with LUDWIG plastic heads. (Please specify right or left mountings from pedal side for gauge placement on each kettle and give timpano model number).

TUNING GAUGES

- | | |
|---------------------|---------------------|
| No. 1060—20" | No. 1062—25" or 26" |
| No. 1061—23" | No. 1063—28" or 29" |
| No. 1064—30" or 32" | |

TIMPANI TRUNKS AND COVERS

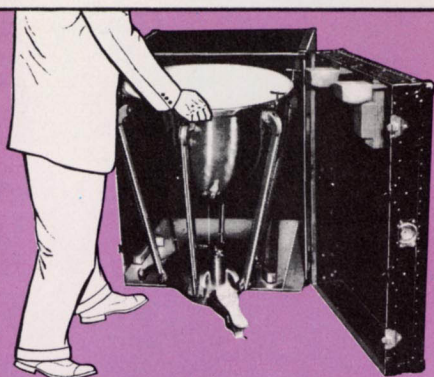

SYMPHONY TIMPANI TRUNKS

Professional quality timpani trunks are reinforced and padded to offer maximum protection when traveling. Galvanized steel floor allows timpani to be rolled in for quick packing.

- No. 821-1—TRUNK FOR 20" DRESDEN TIMPANI, each.
- No. 821-2—TRUNK FOR 20" PROFESSIONAL TIMPANI, each.
- No. 821-3—TRUNK FOR 20" SYMPHONY TIMPANI, each.
- No. 822-1—TRUNK FOR 23" DRESDEN TIMPANI, each.
- No. 822-2—TRUNK FOR 23" PROFESSIONAL TIMPANI, each.
- No. 822-3—TRUNK FOR 23" SYMPHONY TIMPANI, each.
- No. 823-3—SET OF TRUNKS FOR 25" AND 28" SYMPHONY TIMPANI, per pair.
- No. 824-1—SET OF TRUNKS FOR 26" AND 29" DRESDEN TIMPANI, per pair.
- No. 824-2—SET OF TRUNKS FOR 26" AND 29" PROFESSIONAL TIMPANI, per pair.
- No. 824-3—SET OF TRUNKS FOR 26" AND 29" SYMPHONY TIMPANI, per pair.
- No. 825-1—TRUNK FOR 30" DRESDEN TIMPANI, each.
- No. 825-2—TRUNK FOR 30" PROFESSIONAL TIMPANI, each.
- No. 825-3—TRUNK FOR 30" SYMPHONY TIMPANI, each.
- No. 826-1—TRUNK FOR 32" DRESDEN TIMPANI, each.
- No. 826-2—TRUNK FOR 32" PROFESSIONAL TIMPANI, each.
- No. 826-3—TRUNK FOR 32" SYMPHONY TIMPANI, each.



UNIVERSAL AND MACHINE TIMPANI TRUNKS

Top quality, heavy-duty construction offers safety for your timpani when in transit. Suspension sling holds kettle—pedal detaches and is securely protected with supporting blocks.

- No. 821-4—TRUNK FOR 20" UNIVERSAL TIMPANI, each
- No. 821-5—TRUNK FOR 20" MACHINE TIMPANI, each
- No. 822-4—TRUNK FOR 23" UNIVERSAL TIMPANI, each
- No. 822-5—TRUNK FOR 23" MACHINE TIMPANI, each
- No. 823-4—SET OF TRUNKS FOR 25" AND 28" UNIVERSAL TIMPANI, per pair
- No. 823-5—SET OF TRUNKS FOR 25" AND 28" MACHINE TIMPANI, per pair
- No. 824-4—SET OF TRUNKS FOR 26" AND 29" UNIVERSAL TIMPANI, per pair
- No. 824-5—SET OF TRUNKS FOR 26" AND 29" MACHINE TIMPANI, per pair
- No. 825-4—TRUNK FOR 30" UNIVERSAL TIMPANI, each
- No. 825-5—TRUNK FOR 30" MACHINE TIMPANI, each
- No. 826-4—TRUNK FOR 32" UNIVERSAL TIMPANI, each
- No. 826-5—TRUNK FOR 32" MACHINE TIMPANI, each

FIBRE HEAD PROTECTORS

- | | |
|--------------|--------------|
| No. 1070—20" | No. 1074—28" |
| No. 1071—23" | No. 1075—29" |
| No. 1072—25" | No. 1076—30" |
| No. 1073—26" | No. 1077—32" |



FULL DROP TIMPANI COVERS

Full drop covers provide maximum protection for your timpani when not in use. The 28" drop skirt keeps out dirt and dust and prevents unauthorized persons from tampering with the instrument.

- No. 831 S—20" FULL DROP COVER, each
- No. 882 S—23" FULL DROP COVER, each
- No. 896 S—25" AND 28" FULL DROP COVERS, per pair
- No. 884 S—26" AND 29" FULL DROP COVERS, pair
- No. 883 S—30" FULL DROP COVER, each
- No. 881 S—32" FULL DROP COVER, each

DURA HYDE SHALLOW DROP COVERS

- No. 196—20"
- No. 197—23"
- No. 198—26"
- No. 199—29"
- No. 200—32"

LUDWIG LATIN-AMERICAN INSTRUMENTS

ultimate perfection in Latin-American sounds



LUDWIG TUNABLE CONGA DRUMS

Ludwig's TUNABLE CONGA DRUM design features deep tapered shell for authentic tone and resonance. Standard key tuning provides complete control of head tension with a deep seated collar assuring a clear playing surface for hands or mallets. Ideal for the school percussion section or ensemble. Supplied with sling, carrying hook and plastic heads. Sturdy, fully adjustable, chrome plated stand for twin and single conga drums, available as illustrated. Choice of zipper cover or fibre case available at extra cost.

No. 2371P – SINGLE TUNABLE CONGA DRUM, choice of pearl finishes with sling and carrying hooks.

No. 2373P – SINGLE TUNABLE CONGA DRUM, choice of pearl finishes mounted with legs.

No. 2377P – TWIN TUNABLE CONGA DRUMS, with dual mount stand, choice of pearl finishes.

NOTE: Size for all Congas listed is 12" dia. x 27" deep.

No. 2374P – CONGA DRUM only, with clip attachment and stop stud.

No. 5022 – Legs for Single Conga Drum, complete.

No. 1344 – Dual Mount Stand for Twin Conga Drum, complete.

No. 69S – Zipper cover for carrying single conga drum without legs.

No. 286 – Dura-Hyde single conga drum cover.

No. 8888 – Fibre case for carrying single conga drum.



LUDWIG TUNABLE BONGOS

Ludwig professional model TUNABLE BONGOS are supplied with 6" and 8" head diameters in 5½" shell depths. Sturdy, shells are built for extreme high tension required for authentic bongo sound. Conventional key tuning provides instant head tensioning with the least amount of effort. Ludwig bongos equipped with plastic heads are ideal for concert use with finger or stick performance. Mounted on sturdy and fully adjustable chrome plated stand as illustrated. Fibre case available at extra cost.



No. 2358P — TUNABLE BONGOS, choice of pearl finishes.

No. 2357P — TUNABLE BONGOS, choice of pearl finishes with floor stand and clip attachment.

No. 2356P — TUNABLE BONGOS, choice of pearl finishes with clip attachments for mounting on No. 476 Marching Holder.

No. 8122 — Fibre Case for tunable Bongos.

No. 1346 — Bongo floor stand with attachment.

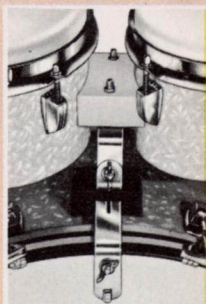

Ludwig Bongos can be mounted on an outfit bass drum in easy playing position for sticks or hands with a hoop holder.

No. 46—Hoop Mount Bongo Holder .

TIMBALE STICKS

No. 311—TIMBALE STICKS, 15" x ¾", 6 pair .

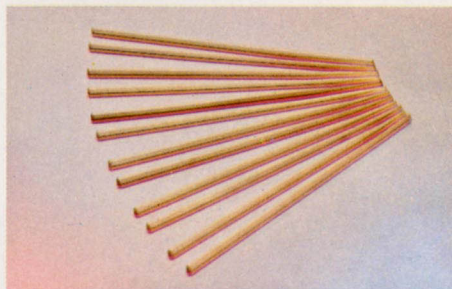

LUDWIG LATIN TIMBALES

Ludwig's authentic Latin-style TIMBALES have the true latin sound so important for today's popular rhythms. Shells are beautifully finished in brass, copper or chrome, highly buffed and polished to a gleaming luster. Sizes: 13" and 14" head diameters with 6½" shell depths. Supplied complete with adjustable folding stand for seated or standing playing positions. Mounted with plastic heads and triple-flanged counterhoops. Cover or fibre case to hold timbales, extra.

No. 2351—TIMBALES, copper finish, stand and plastic heads.

No. 2345—TIMBALES only—copper finish, plastic heads, clip attachments and stop studs.

No. 2353—TIMBALES, brass finish, stand and plastic heads.

No. 2347—TIMBALES only—brass finish, plastic heads, clip attachments and stop studs.

No. 2359—TIMBALES, chrome finish, stand and plastic heads

No. 2349—TIMBALES only—chrome finish, plastic heads, clip attachments and stop studs.

No. 1348—Timbale stand only, chrome.

No. 65 S—Cover to hold both timbales.

No. 7150—Fibre case to hold both timbales.

TIMBALE COW BELL HOLDERS

Single and double cow bell holders for timbales attach to collar tension rods . . . holds cow bell rigidly in playing position.

No. 126-1—Single Cow Bell Holder.

No. 127-1—Double Cow Bell Holder.

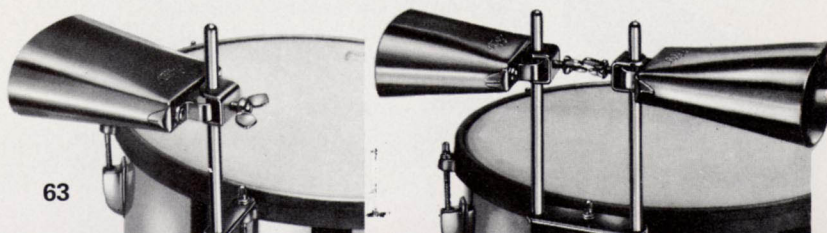

LUDWIG... *the new sounds of Latin percussion*



GOLDEN TONE COW BELL

A heavier, harder alloy gives Ludwig's Cow Bells the ideal sound for today's sophisticated Latin rhythms. Fully welded seams guarantee rich, bright effects. Finished in golden bronze plating.

No. 128—4" COW BELL
No. 129—5" COW BELL

special effect cow bells

THE BLACK BEAUTY CHA-CHA BELL

An effective all-around cow bell, this model is most often used for Cha-Cha rhythms. Exclusive SONI-CURVE surface produces maximum volume. 6" overall length.

No. 2388—BLACK BEAUTY COW BELL .

TIMBALE COW BELL

Also featuring the exclusive SONI-CURVE, this model, because of its big, solid sound is most frequently preferred for driving, up-tempos beats. 9" overall length.

No. 2389—TIMBALE COW BELL .

BONGO (HAND) COW BELL

Of a heavier gauge steel, this cow bell produces a very deep sound. It is designed to be played handheld with Bongo Cow bell Beater. 9" overall length.

No. 2390—BONGO COW BELL .

MAMBO COW BELL

A sharply defined raised center makes this model extremely versatile. It is capable of many effects and its unique design produces a maximum volume.

No. 2391—MAMBO COW BELL .



AGOGO BELLS

From Bahia in Brazil comes this unique percussion sound. Two richly toned bells, pitched approximately a third apart are played by any variety of strikers to produce authentic and exciting effects. They are particularly favored by Latin-style drummers for "hard" Sambas and Batucata, and also lend themselves well to up-tempo Cuban rhythms.

No. 2387—AGOGO BELLS .

AGOGO BELLS MOUNTING BRACKET

For mounting Agogo Bells to bass drum or timbales.

No. 2387-1—AGOGO BELL MOUNTING BRACKET .

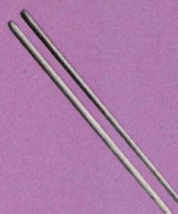

COW BELL STICKS

Just the right weight, length and diameter for proper tone and playing ease of modern cow bell rhythms. Solid hickory sticks.

No. 312—COW BELL STICKS, pair.

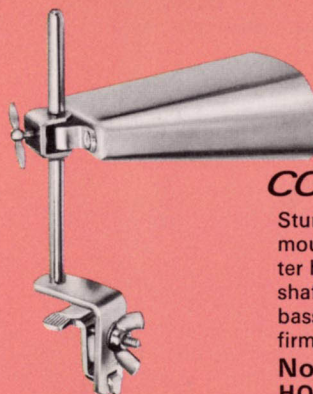

COW BELL HOLDER

Sturdily constructed cow bell holder mounts directly on bass drum counter hoop or edge of trap table. Main shaft is 6" high for use with small bass drums. "U" clamp holds bell firmly in position.

No. 133—COW BELL HOLDER .

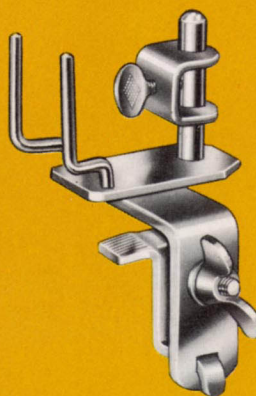

BELL-BLOCK HOLDER

The ideal holder for cow bell and wood block combination. Mounts directly on bass drum hoop or edge of trap table.

No. 1323—BELL-BLOCK HOLDER .

Today Latin rhythms are enjoying a popularity like never before. And for the most authentic of Latin Sounds, Ludwig presents these special instruments.

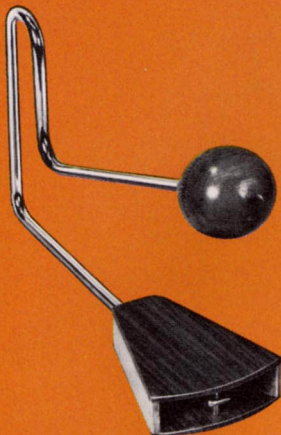

VIBRA-SLAP

The Vibra-Slap delivers the same sound as the "Jawbone", but with a much greater consistency and strength. The unique sound it produces is not necessarily confined to Latin music but also fits in with "rock" and other pop styles. Lasting construction.

- No. 2383—VIBRA-SLAP (Small)
- No. 2384—VIBRA-SLAP (Large)

AFUCHE (CABASA)

The AFUCHE provides another unusual Brazilian rhythm sound. Metal beads surrounding a simulated gourd produce a tight, dry Cabasa sound with extra "highs" that provide a totally different effect.

- No. 2380—AFUCHE, Small
- No. 2381—AFUCHE, Medium
- No. 2382—AFUCHE, Large

AFRICAN CLAVES

Featuring a semi-hollow design, these Claves produce a tone much richer and deeper than regular claves. They have a carrying power that easily cuts through even the biggest band's sound.

- No. 2385—AFRICAN CLAVES, Small, pr.
- No. 2386—AFRICAN CLAVES, Large, pr.

METAL TUBO (SHAKER)

Popular in Brazil, the Metal Tubo is a hand held metal shaker filled with balanced shot. The effect it produces is similar to the Ka-Me-So but with a crisper, more definite sound.

- No. 2392—METAL TUBO, Small.
- No. 2393—METAL TUBO, Large.

standard percussion

CLAVES

These top quality claves produce an authentic sound so important to today's popular Latin rhythm. Made of hand turned rosewood, lacquered and polished to a gleaming luster.

- No. 2361—CLAVES, Small, per pair.
- No. 2368—CLAVES, Medium, per pair.

MARACAS

Hand turned from choice wood, and filled with balanced shot. These Maracas provide a clear, high-pitched extension of the Latin beat. Hand painted design and lacquer finish.

- No. 2364—MARACAS, Small, per pair.
- No. 2365—MARACAS, Medium, per pair.

GUIRO

Ludwig's *Professional Quality* hand carved GUIRO produces the authentic Latin tone. Evenly spaced deep grooves provide clear tone and resonance. Supplied with quality scraper.

- No. 2366—GUIRO, Small.
- No. 2367—GUIRO, Medium.

KA-ME-SO

Producing a sound similar to the Maracas, the KA-ME-SO also is capable of long rolls for legato passages. Played by turning end to end or with a gentle rolling motion. Hand painted and polished.

- No. 2369—KA-ME-SO

LUDWIG[®]
MUSSER *the quality standard*

in mallet percussion: XYLOPHONES with KELON[®]



PORTABLE KELON[®] XYLOPHONE

The Ludwig PORTABLE XYLOPHONE meets the highest standards set by today's top recording and symphonic artists. Tonal quality, resonance and tuning are beyond compare. Modern design and sturdy construction guarantee many years of rugged use and lasting beauty. A full 3½ octave keyboard of durable KELON is expertly tuned to A-442 for the extra tonal edge preferred by most professional groups. Resonators detach from bottom and legs fold to a locking position for easy carrying. Shallow drop cover and three pairs of suitable mallets included; cases extra.

Here is the ideal Xylophone for every professional or school percussion section. An instrument of the finest quality designed to meet the growing demands in mallet percussion.

SPECIFICATIONS:

Keyboard: 3½ octaves, F⁴ to C⁸

Bars: 1½" wide and 7/8" thick

Height: 33½" — Length: 54"

Width low end: 32" — high end: 13"

Weight: 70 pounds

No. M51—PORTABLE KELON XYLOPHONE

KELON[®] SPACE-AGE MATERIAL

KELON, a Ludwig exclusive, is one of the promised benefits to come from space-age technology. A product of advanced research and development, laboratory-tested and performance-proven KELON exhibits all of the desirable attributes of natural materials while virtually eliminating the shortcomings of conventional rosewood bars. Ludwig instruments with bars of KELON possess three distinct advantages over rosewood bar mallet instruments: (1) greater tonal stability and true pitch under extreme variations of temperature and humidity; (2) greater durability and impact-resistance to even the hardest of ball mallets; (3) greater tonal projection with the sound power needed to carry through amplified sound or a full symphony orchestra. Widely acclaimed by leading professionals, including the Chicago Symphony, KELON is now available on all Ludwig Xylophones and most Marimbas.



ELITE KELON® XYLOPHONE

The ELITE XYLOPHONE is one of the finest keyboard instruments for grade and junior high school use. This instrument is ideal for the school desiring a professional quality instrument at an economical price. The ELITE has the same resonators and thickness of bars as most professional xylophones to produce tone quality comparable to that of instruments costing much more. The bars of the keyboard are of durable KELON and are precisely tuned to A-442. Aluminum resonators are finished in silver-satin lacquer; square aluminum legs have baked-on black lacquer finish. Shallow drop cover and two pairs of suitable mallets included; case extra.

SPECIFICATIONS:

Keyboard: 3 octaves, C⁵ to C⁸
 Bars: 1½" wide and 7/8" thick
 Height: 34" — Length: 44¾"
 Width low end: 28½" — high end: 12¼"
 Weight: 54 pounds

No. M42—ELITE KELON XYLOPHONE

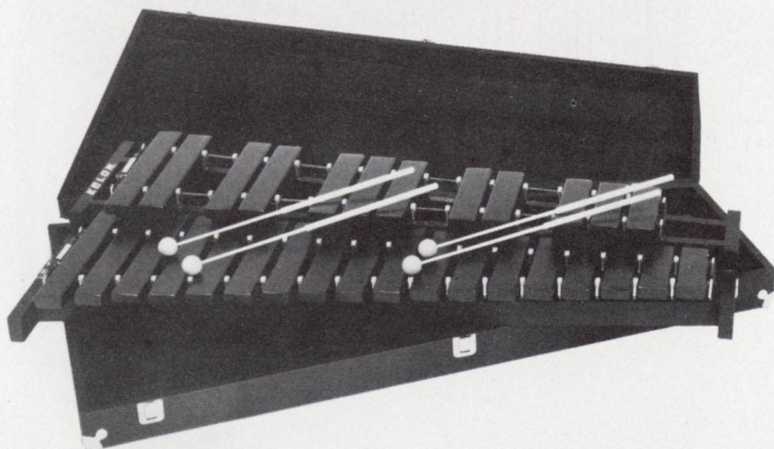
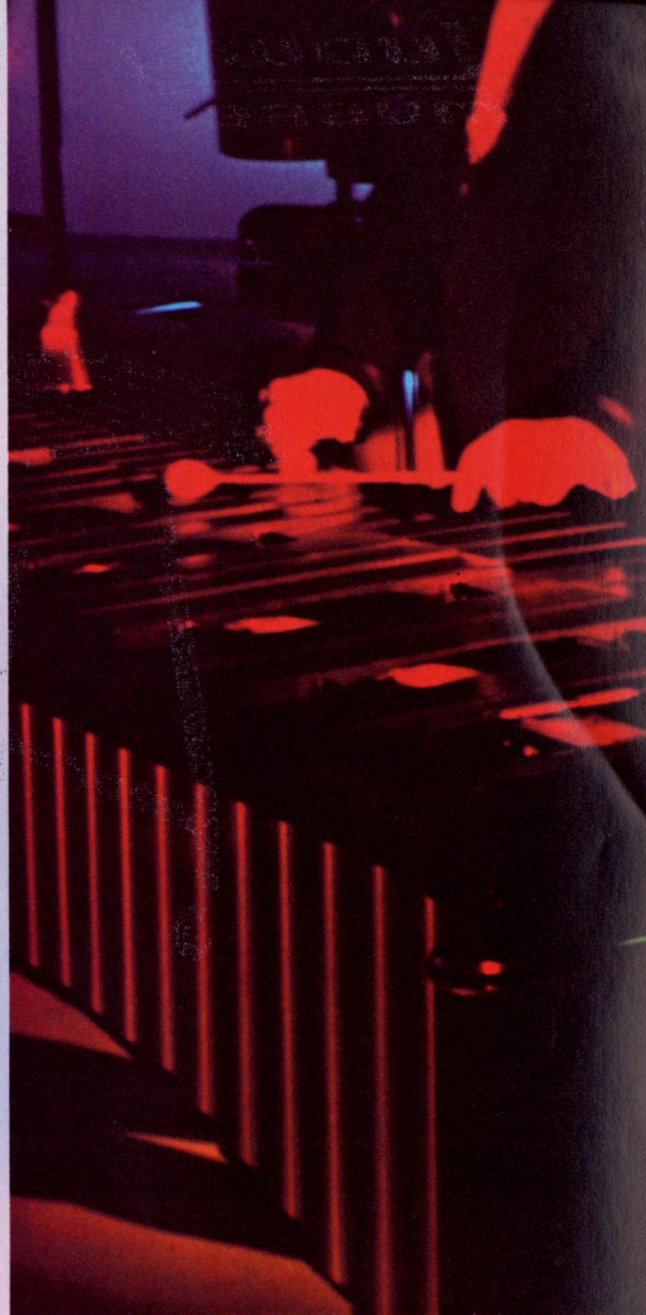

PICCOLO KELON® XYLOPHONES

The lightweight, portable PICCOLO XYLOPHONE is ideally suited for the professional "show drummer" and for use in the school music department. The bars of the keyboard are of durable KELON, are finely tuned to A-442 and finished to provide an instrument of lasting satisfaction. Keyboard is built into sturdy carrying case with removable top. Two pairs of suitable mallets included.

No. M41—PICCOLO KELON XYLOPHONE SPECIFICATIONS:

Keyboard: 2½ octaves, G⁵ to C⁸
 Bars: 1½" wide and 5/8" thick
 Length: 38"
 Width low end: 22" — high end: 12"
 Weight with case: 31 pounds

No. M39—3-Octave Model PICCOLO KELON XYLOPHONE SPECIFICATIONS:

Keyboard: 3 octaves, C⁵ to C⁸
 Bars: 1½" wide and 5/8" thick
 Length: 45"
 Width low end: 24" — high end: 12"
 Weight with case: 44 pounds



**No. M621
ACCESSORY
RESONANCE
CONTROL**
Pat. Pend.

**WINDSOR II
PORTABLE KELON® MARIMBA**

A full 4-octave Kelon Marimba combining high quality and low cost. The new M31 Marimba features keyboard bars of Kelon—the same miracle material used on the performance-proven M51 Xylophone. For extra sturdy construction, the M31 employs heavy gauge extruded aluminum legs, solid frame, and rigid steel braces. Free-rolling casters and folding legs provide easy portability with one pair of locking casters for in-use stability. The M31 "Windsor II" is enhanced by its satin-silver lacquered resonators, charcoal black baked enamel legs, and triple-plated brushed chrome trim. Shallow drop cover included.

SPECIFICATIONS:

Keyboard: Full four octaves,
C³ thru C⁷ tuned to A-440.
Removable KELON Bars, 1 1/2" x 5/8"
Height: 33 3/4" overall: diatonic scale 32"
Width low end: 30 3/4" — high end: 11 3/8"
Length: 61 1/4" — Weight: 76 pounds
Accessories included:
Four pairs of suitable Mallets.

No. M31—WINDSOR II KELON MARIMBA

No. M621—ACCESSORY RESONANCE CONTROL

For use in solo work with florid or fast passages and in studio recording where less resonance is preferred. Pat. Pend.

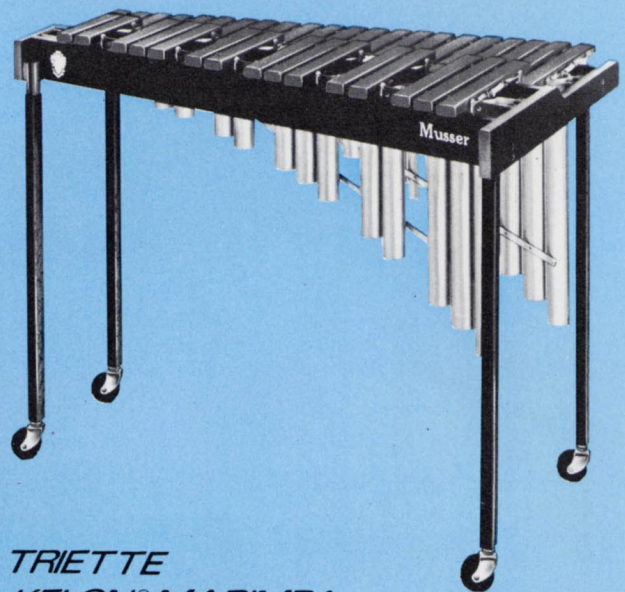

**TRIETTE
KELON® MARIMBA**

Here is a 3 octave marimba designed especially for the beginning keyboard percussionist. The durable KELON bars, finely tuned to A-440, are the same size and range as the No. 45 Vibe, thus allowing the student to progress from skills learned on the marimba to the vibe with little difficulty.

Baked black wrinkle finish legs; gunmetal lustre finish frame; silver-satin resonators. Light in weight, the TRIETTE packs into only 2 cases for easy portability. Shallow drop cover and two pairs of suitable mallets included; cases extra.

SPECIFICATIONS:

Keyboard: 3 octaves, F³ to F⁶
Bars: 1 1/2" x 5/8"
Height: 35" — Length: 45 1/4" — Width low end: 28" — high end: 13" — Weight: 51 pounds

No. M61—TRIETTE KELON MARIMBA

No. M21—KELON PREP MARIMBA (not shown)

SPECIFICATIONS:

Keyboard: 2 1/2 octaves, C⁴ to F⁶
Bars: 1 3/8" x 5/8"
Height: 33" — Length 36" — Width low end: 25 1/4" — high end: 12 5/8" — Weight: 30 pounds

BRENTWOOD MARIMBA

The BRENTWOOD answers the need for a 4-octave marimba with tone quality and beauty only Ludwig master craftsmen can produce. The scientifically graduated tone bars, expertly tuned to A-440, are evenly voiced throughout the entire range. The exceptionally large resonators are perfectly tuned to their corresponding bars giving rich deep tones usually found in larger, more expensive instruments. The hinged rails plus lightweight resonators make this an exceptionally portable 4-octave instrument.

Finished in black ends and rails, natural rosewood keyboard, rich silver-satin resonators and bright chrome trim. Packs into 3 cases. Shallow drop cover and four pairs of suitable mallets included; cases extra.

SPECIFICATIONS:

Keyboard: 4 octaves, C³ to C⁷
Bars: 2" x 1 5/16" to 1 3/8" x 5/8"
Height: 35" — Length: 68" — Width low end: 29 1/2" — high end: 14" — Weight: 70 lbs.

No. M-30—BRENTWOOD MARIMBA.

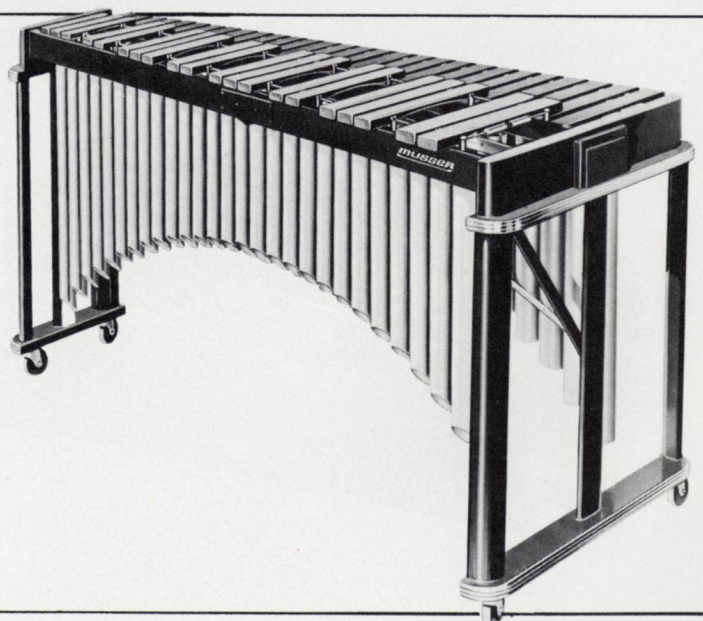



CONCERT GRAND/CENTURY MARIMBAS

Two magnificent models of unequalled perfection... here are truly instruments of ultimate perfection in designed beauty and tonal performance where quality craftsmanship is obvious in every detail. The new "wide bar" CENTURY features full four octave keyboard of genuine Honduras rosewood, expertly tuned to A-440. The Concert Grand model extends the range to low A, providing a 4½ octave marimba. The added B, B^b and A expand the versatility of this superior "artist's" instrument.

Exclusive Ludwig design offers ease of setting up and transport. The ends and rails are hand finished in striking gun-metal black. The keyboard is natural rosewood, and the arched resonators are of lustrous gold finish. Ends are covered with handsome black vinyl.

Cross rails and resonators are hinged for compact folding; keyboard can be removed and replaced in seconds. The CONCERT GRAND model packs into 5 cases; the CENTURY packs into 4 cases. Shallow drop cover and four pairs of suitable mallets included. Fibre cases available at extra cost.

SPECIFICATIONS: CONCERT GRAND MARIMBA

Keyboard: 4½ octaves, A² to C⁷
Bars: 2½" x 1⅝" to 1⅝" x ¾"
Height: 35"—Length: 81⅝"—Width low end: 31"—
high end: 15"—Weight: 150 lbs.

No. M-250—CONCERT GRAND MARIMBA,
Illustrated.

SPECIFICATIONS: CENTURY MARIMBA

Keyboard: 4 octaves, C³ to C⁷
Bars: 2½" x 1⅝" to 1⅝" x ¾"
Height: 35"—Length: 75¾"—Width low end: 31"—
high end: 15"—Weight 131 lbs.

No. M-150—CENTURY MARIMBA

LUDWIG[®]
MUSSER

*the quality standard
in mallet percussion: VIBES*



CENTURY VIBE

an instrument of ultimate beauty in tone and design

VIBE MOTOR

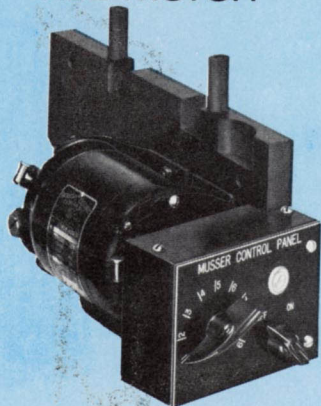

The Musser Vibe motor, standard on the Century and Pro Vibes, is the finest available . . . offering quiet, trouble-free performance with a minimum of maintenance. The induction Capacitor-type motor eliminates brushes and arcing; bakelite gear and Mercury switch provide quiet operation with no pick-up interference for recording; capacitor and rheostat govern speed of motor. 115 volts; 60 cycle AC; 1/140 HP; rubber mounted for minimum noise level.

The CENTURY is truly the masterpiece among vibraphonic instruments, selected for its superior quality by leading vibe artists throughout the world. Some of the features found on the CENTURY are: thicker and wider, more resonant bars, expertly tuned to A-440, enclosed motor and belt pulleys, self-aligning pulsator shafts, arched-mitered resonators and lifetime variable speed motor with conveniently located control panel which houses the silent Mercury switch, on-off pilot light and speed control.

The CENTURY is finished in handsome gun-metal black ends and rails; keyboard and resonators are of lustrous gold finish. Solid end pieces are covered with new scuff resistant material in matching black. Packs into 5 cases for transport. Supplied with shallow drop covers and three pairs of suitable mallets; carrying cases extra.

SPECIFICATIONS:

Keyboard: 3 octaves, F³ to F⁶
Bars: 2¼" x ½" to 1½" x ½"
Motor: 115 Volts, 60 cycle AC
Height: 33½"—Length: 57"
Width: low end: 29½"—high end: 14½"
Weight: 140 lbs

No. M-75—CENTURY VIBE.

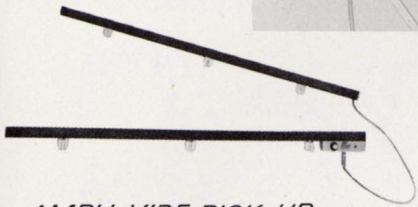
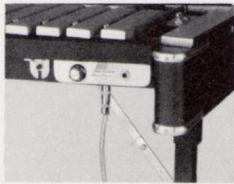

AMPLI-VIBE PICK-UP

Converts conventional acoustic vibes to full electronic sound power as needed for today's music. Ampli-Pickup is the ideal accessory for all vibists — a "must" when performing with groups and stage bands. Easily mounted to all popular makes of vibes, the two housings are simply fastened beneath the keyboard without in any way defacing the instrument. The output of Ampli-Pickup connects directly to the input of any good flat-response power amplifier. Master gain control, conveniently located, permits adjustment of volume level from the instrument. Employs highly advanced electronic circuitry and quality components, throughout.

Model 9140 — 40" length for DEAGAN models 35, 510, 512 and 555.

Model 9144 — 44" length for MUSSER models 45, 45V and 48 (One Niter).
DEAGAN models 580, 581 and 582
JENCO models 420 thru 424, 430 thru 434, 622, 635 and 636.

Model 9149 — 49" length for DEAGAN models 45, 48, 55, 144, 145, 585, 590, 592, 1000 and 1100.
JENCO models 406 thru 414 and 620 thru 624 (Pro).

Model 9154 — 53" length for MUSSER models 55 (Pro) and 75 (Century).

Note — Some vibraphone models require removal of carrying handle or slight modification of decorative trim for proper installation which in no way affects the instrument.



PRO VIBE

The Ludwig PRO VIBE is an ingenious combination of brilliant sound and portability. Here are the features that make the PRO VIBE the new standard of quality in portable vibraphones: full-range keyboard; wider, more resonant bars, perfectly tuned to A-440; enclosed motor and belt pulleys; lifetime variable speed motor; self-aligning pulsator shaft, and arched-mitered resonators. Legs and crossbars of the frame are square extra hard aluminum, finished with durable black crackle coating. Guards are gleaming polished aluminum. Packs in only 3 cases! Shallow drop cover and three pairs of suitable mallets included; cases extra.

SPECIFICATIONS:

Keyboard: 3 octaves, F³ to F⁶
Bars: 2¼" x ½" to 1½" x ½"
Motor: 115 volts, 60 cycle AC
Height: 34¼" — Length: 56"
Width: low end: 30" — high end: 15"
Weight: 95½ lbs.

No. M-55—PRO VIBE.

ONE-NIGHTER PORTABLE VIBE

The Ludwig ONE-NIGHTER combines easy portability with beautiful appearance, exquisite tone quality and perfect intonation. The brilliant tone of the portable vibe is full bodied and rich, with unusual carrying power. The keyboard bars are finely tuned to A-440 and have a smooth satin-silver finish. The frame is soft black, beautifully set with gleaming polished aluminum guards. Legs and crossbar are square, extra hard aluminum for light weight, attractively finished with durable crackle coating. Arched resonators are individually tuned and are completely insulated from carriage.

The ONE-NIGHTER is available with either single speed or variable speed motor. Packs easily into three cases. Shallow drop cover and three pairs of suitable mallets included; cases extra.

SPECIFICATIONS:

Keyboard: 3 octaves, F³ to F⁶
Bars: 1½" x ½"
Motor: 110 Volts, 50-60 cycle AC
Height: 34¼" — Length 47"
Width: low end: 29¾" — high end: 13½"
Weight: 78¼ lbs.

No. M-48—ONE-NIGHTER VIBE, single speed .

No. M-45—ONE-NIGHTER, variable speed .



LUDWIG ... blend of tone, strength & playing ease!

perfection in modern bell lyras

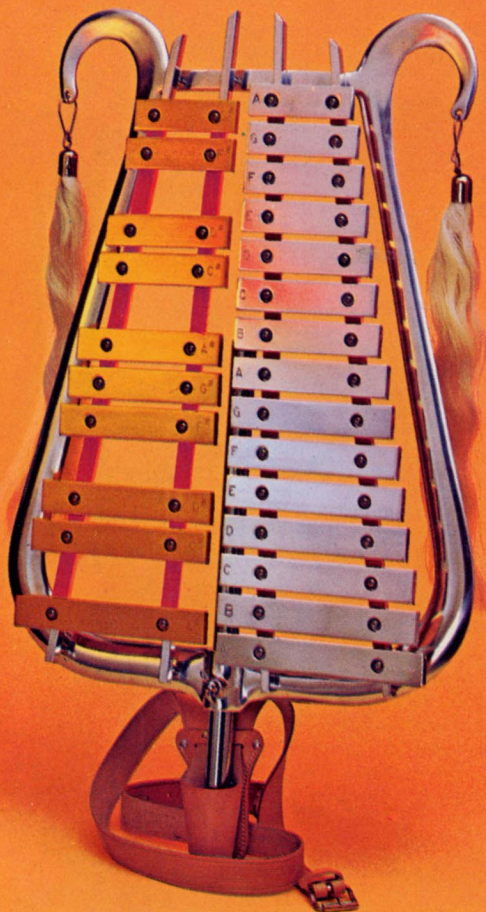

No. M-2044

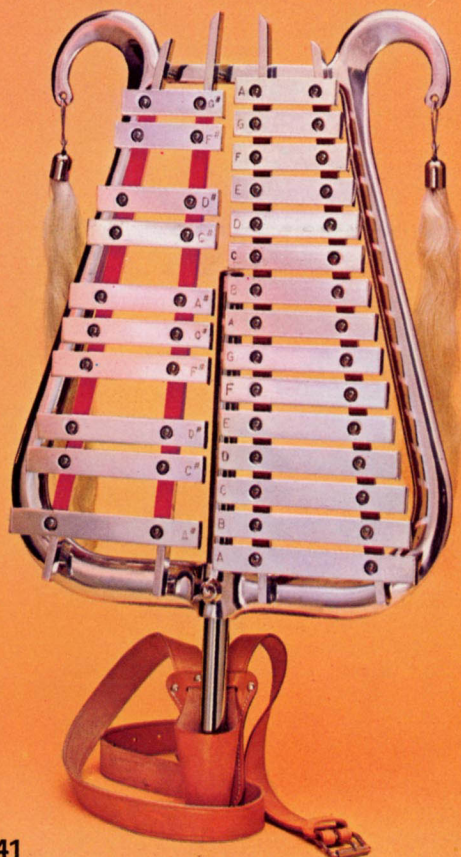

No. M-2041

CONCERT BAND BELLS

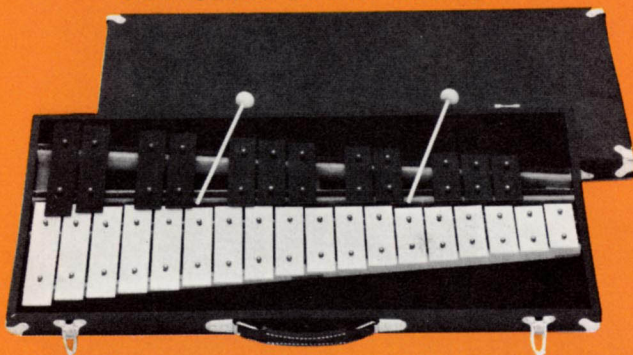

No. M-655

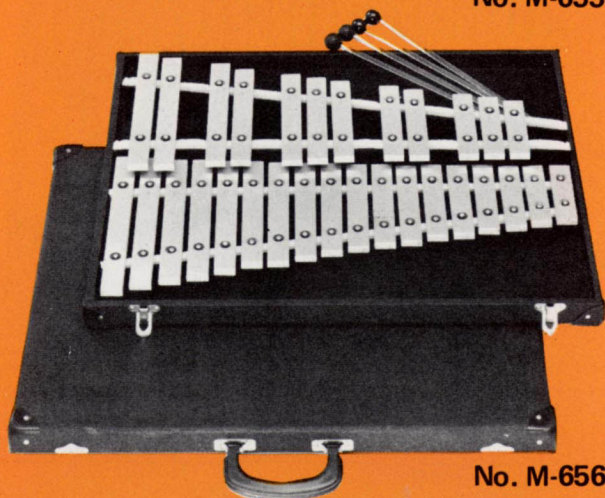

No. M-656

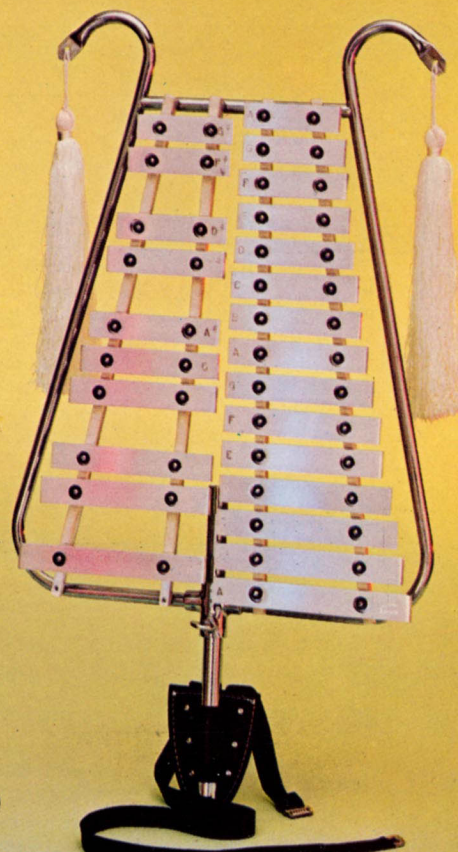

No. M-2040

THE CLASSIC BELL LYRA / *deluxe model*

Ludwig's advance design and quality craftsmanship has set new standards of perfection in modern bell lyras. Here is a blend of tone, beauty, strength and ease of playing, to provide the finest bell lyra on the market. Ludwig bell lyras are made in our own plant and tuned to A-440 by our own expert tuners. The deluxe model is ideal for use on the march as well as in the concert hall. Accidentals are finished in rich gold; naturals are bright polished aluminum.

SPECIFICATIONS:

2 octaves, 25 bars A⁵ to A⁷

Aluminum bars: 1 1/4" wide, 3/8" thick. Raised accidentals; one piece aluminum frame, "Two-Tone" keyboard; felt covered mounting rails; Total weight: 13 lbs.

No. M2044—DELUXE BELL LYRA complete with mallets, plumes, carrying strap and zipper cover.

THE MARCHING BELL LYRA / *standard model*

The Standard Model marching bell lyra is a quality instrument built to the high standards of the Ludwig tradition. The full two octave chromatic keyboard is expertly tuned to A-440. The aluminum bars and frame are highly polished to a gleaming lustre. Durability, lightweight and ease of playing make the Standard Model tops in its field

SPECIFICATIONS:

2 octaves, 25 bars A⁵ to A⁷

Aluminum bars: 1" wide, 3/8" thick; one piece aluminum frame; felt covered mounting rails; Total weight: 11 lbs.

No. M2041—STANDARD BELL LYRA complete with mallets, plumes, carrying strap and zipper cover.

THE STADIUM BELL LYRA / *lightweight*

In presenting the bell lyra Model No. 2040, Ludwig offers the best quality, and most lightweight, economy-priced bell lyra on the market! Ideal for grade school or Junior High school marching bands, where weight and price are major factors, the bell lyra is constructed of satin-finish aluminum bars tuned to A-440, mounted on a triple chrome plated tubular frame and decorated with elegant white nylon plumes. Sling, mallets, carrying cover and adjustable carrying tube included. Here is the perfect bell lyra for your young school market!

SPECIFICATIONS:

Full-range, 2 octaves, 25 bar A⁵ to A⁷

Aluminum bars: 1" x 1/4";

one piece tubular frame

felt covered mounting rails;

weight: 6 3/4 lbs.

No. M2040—BELL LYRA complete

STEEL BELLS FOR BANDS - ORCHESTRAS

Recommended for use at the Elementary level. Full, 2 1/2 octave range, high grade, 1/8" x 1 1/4", tempered steel bars are carefully tuned to A-440 and mounted in a carrying case with reinforced corners. Complete with one pair of suitable mallets. Optional, at additional cost, is a lightweight, adjustable sturdy bell stand (No. K-608) for support.

**No. M-655 - CHROMATIC
STEEL BELLS**
(G⁵ to C⁸).

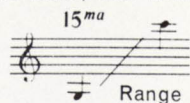

ALUMINUM BELLS FOR BANDS - ORCHESTRAS

Recommended for use at the Jr. High level. Full, 2 1/2 octave range, high grade, 3/8" x 1", highly polished aluminum alloy bars, carefully tuned to A-440 and mounted in a carrying case with reinforced corners. Complete with two pair of suitable mallets. Stand available at extra cost.

**No. M-656 - CHROMATIC
ALUMINUM BELLS**
(G⁵ to C⁸)

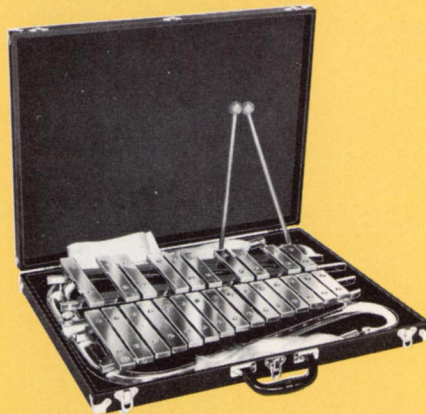
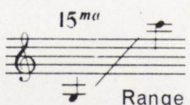

HARD SHELL BELL LYRA CASE

Here's added protection plus an ideal arrangement for using marching bell lyra in concert as orchestra bells. Case features durable leatherette covering, felt lining and quality hardware. Designed for either deluxe or Standard models.

No. M-8000—HARD SHELL BELL LYRA CASE.

CONCERT BELL LYRA STAND

A quality concert bell lyra stand made from heavy-gauge stock. Stand is fully adjustable to any position and folds for easy transporting. Triple chrome plating adds to the beauty and long life.

No. M-2049—CONCERT BELL LYRA STAND.

Adapter to attach No. 2040 Bell Lyra to No. 2049 Bell Lyra Stand

No. P-2464A.

No. M-2046—BELL LYRA MUSIC HOLDER, chrome plated.

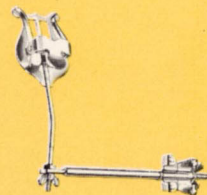

LUDWIG OFFERS OUTSTANDING QUALITY

Ludwig bell lyras are supplied complete with 2 bell lyra mallets, 2 plumes, leather carrying strap and a zipper cover at no additional cost. These items may be purchased separately if desired.

**No. M-640—Hard nylon
Bell Lyra mallets,**
per pair.

**No. M-2047—Leather
carrying strap,
TAN.**

**No. M-2047W—
Leather carrying
strap, WHITE.**

**No. M-639—Hair
plumes 16" long,
white only,**
per pair.

**No. M-2048—Zipper
cover for No. 2044
model.**

**No. M-2048A—
Zipper cover for
No. 2041 model.**





Strikingly new and modern in concept, the new Ludwig M630 Concert Chimes are the last word in contemporary chime design. Featuring 1½" diameter tubes, super-rigid aluminum frame, "Unibar", one piece damper mechanism with wide foot pedal, ultra-modern appearance, and many exclusives. Comes complete with genuine rawhide mallet. Optional accessories available at extra cost.

- No. M630 MUSSER CONCERT CHIMES** (Chrome and Satin Aluminum Finish)
- No. M631 MUSSER CONCERT CHIMES** (Lacquered Brass and Gold Finish)
- No. M637 DURA-HYDE COVER** for M630 and M631 Chimes
- No. M336 RAWHIDE CHIME MALLETT**

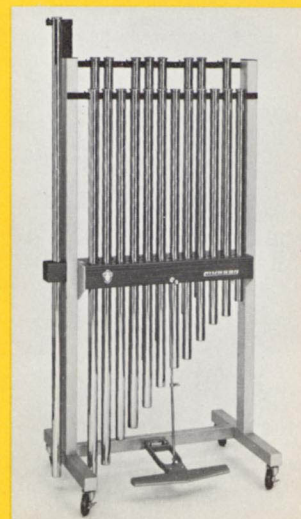

An accessory chime hanger is available for adding on one lower note at a time. Five add-on chimes are available at extra cost as follows:

- No. M629** Low G⁴ Chime
- No. M628** Low G^{#4} Chime
- No. M627** Low A⁴ Chime
- No. M626** Low A^{#4} Chime
- No. M625** Low B⁴ Chime

- No. M633** Accessory Chime Hanger
- No. M634** Set of five low chimes, (M625, M626, M627, M628, M629)



SPECIFICATIONS:

Range: 20 notes, full 1½ octaves, C⁵ to G⁶, tuned to A-442
 Height: 69" —Width: 32½"
 Weight: 165 lbs.
 Tubes: 1½" outside diameter, Chromium plated seamless brass tubing.
 Frame: Extruded, satin-brushed, clear anodized aluminum.
 Damper: Rotary UNIBAR construction.



CLASSIC CHIMES

A modern chime with traditional design. . .the CLASSIC CHIMES with added F# and G extends range upwards to allow performance in additional keys without transposing down for these notes. Tubes are of the finest brass available, carefully cut and precision tuned to A-442. Special tube caps provide greater tonal resonance and carrying power. New cable tube suspension will not break. An entirely advanced damper mechanism assures instant, trouble free control. Frame is finished in bright gold metallic lacquer; tubes are polished brass. Supplied with one rawhide mallet. Fleece lined vinyl cover and/or cases, extra.

Specifications:

Range: 1½ octaves, C⁵ to G⁶

Tubes: 1¼" outside diameter

Tube length: Low end 58" —high end 32¼"

Height: 64" —Width: 32"

Weight: 185 lbs.

No. M635 CLASSIC CHIMES

No. M636 CHIME COVER

No. M336 RAWHIDE CHIME Mallet

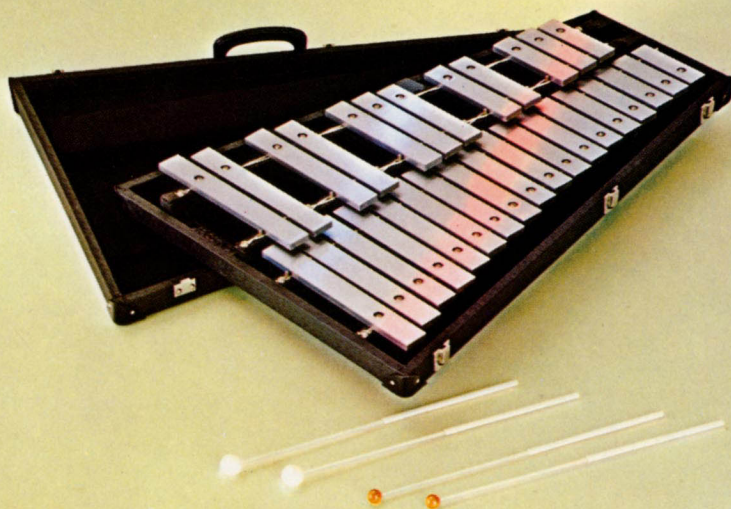

BELLS FOR CONCERT BAND/ORCHESTRA

Ludwig's CONCERT BAND BELLS are without comparison in brilliance, resonance and response. Made of the finest high-carbon tempered steel available, the bars are expertly tuned to A-442. Bars are satin finished and triple chrome plated. An exclusive mounting process allows each note to ring free with greater tonal resonance. The keyboard is mounted in a sturdy, shaped case with detachable lid. Two sets of mallets are supplied with each instrument.

Specifications:

Keyboard: 2½ octaves, G⁵ to C⁶

Bars: 1¼" wide x ¾" thick

Case size: Length; 29" —Width low end; 20"
—high end; 10"

Weight, complete: 42 lbs.

No. M645 —Concert Band Bells

No. M646 —Concert Band Bells with New
Hand Damper (*not shown*)

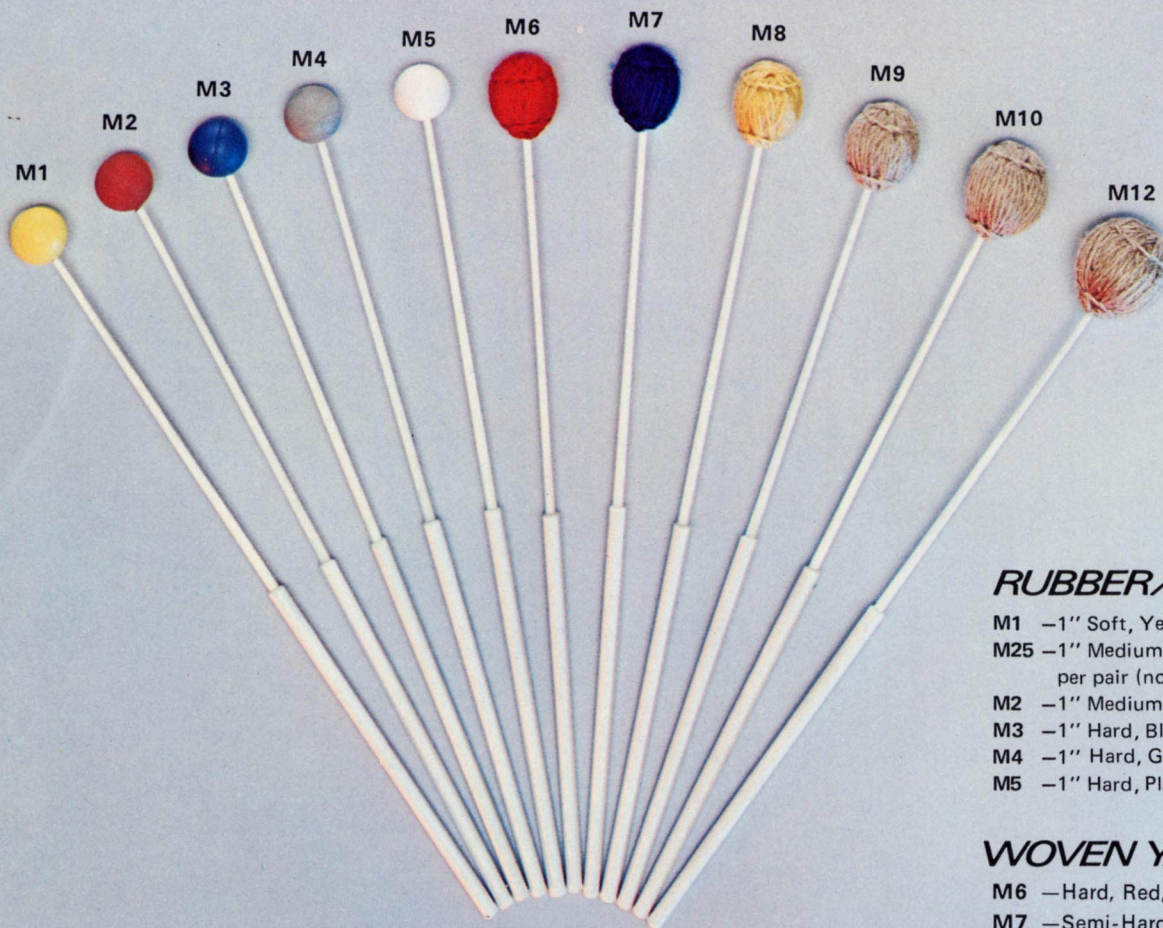

FIBERGLASS HANDLE MALLETS

New in concept! Polyethylene fiberglass handles feature good flexibility along with long lasting durability. No warping; evenly matched for balance. All mallet heads are of special formula rubber; only the finest grade yarn used on covered mallets. Each pair is carefully graded, matched and tested by experts, assuring complete satisfaction.

RUBBER/PLASTIC

- M1 -1" Soft, Yellow, per pair.
- M25 -1" Medium, Soft, Black per pair (not illus.)
- M2 -1" Medium, Red, per pair.
- M3 -1" Hard, Blue, per pair.
- M4 -1" Hard, Gray, per pair.
- M5 -1" Hard, Plastic, per pair.

WOVEN YARN

- M6 -Hard, Red, per pair
- M7 -Semi-Hard, Blue, per pair . . .
- M8 -Medium Soft, Yellow, per pair
- M9 -Soft, Gray, per pair
- M10 -Soft, Gray, (larger), per pair.
- M11 -Medium, Green, per pair.
(Not Illustrated)
- M12 -Low Register Mallets,
Gray, per pair.

BRASS MALLETS

Brass mallets are especially constructed to produce a strong, clear response from the Concert Band Bells. Brass balls are mounted on flexible durable fiberglass handles for use with Concert Band Bells.

- M14 -BRASS BELL MALLETS,
per pair.

WOOD MALLETS

Specially developed hard maple wood ball mallets with fiberglass handles are particularly valuable for new sounds on Concert Band Bells in orchestral work.

- M15 -HARD MAPLE, per pair.

CORD WOUND FIBERGLASS MALLETS

These new mallets are wound with the finest four strand rayon sheen cord by specially developed machines to hold close tolerances. The exceptional long-lasting quality and precision manufacturing make these mallets ideal for use on any keyboard instrument. Handles are fiberglass.

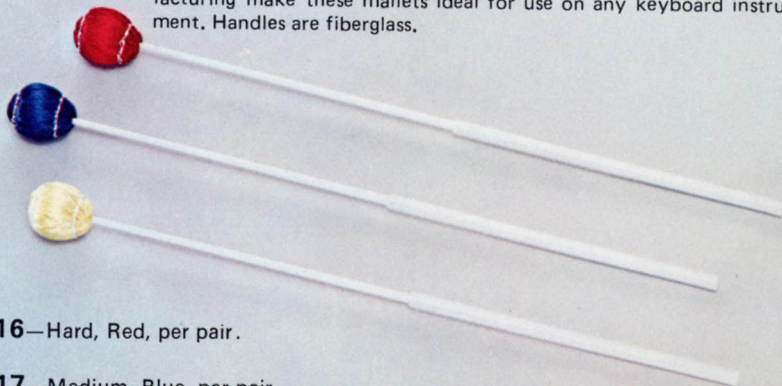

- M16 -Hard, Red, per pair.
- M17 -Medium, Blue, per pair.
- M18 -Soft, Yellow, per pair.

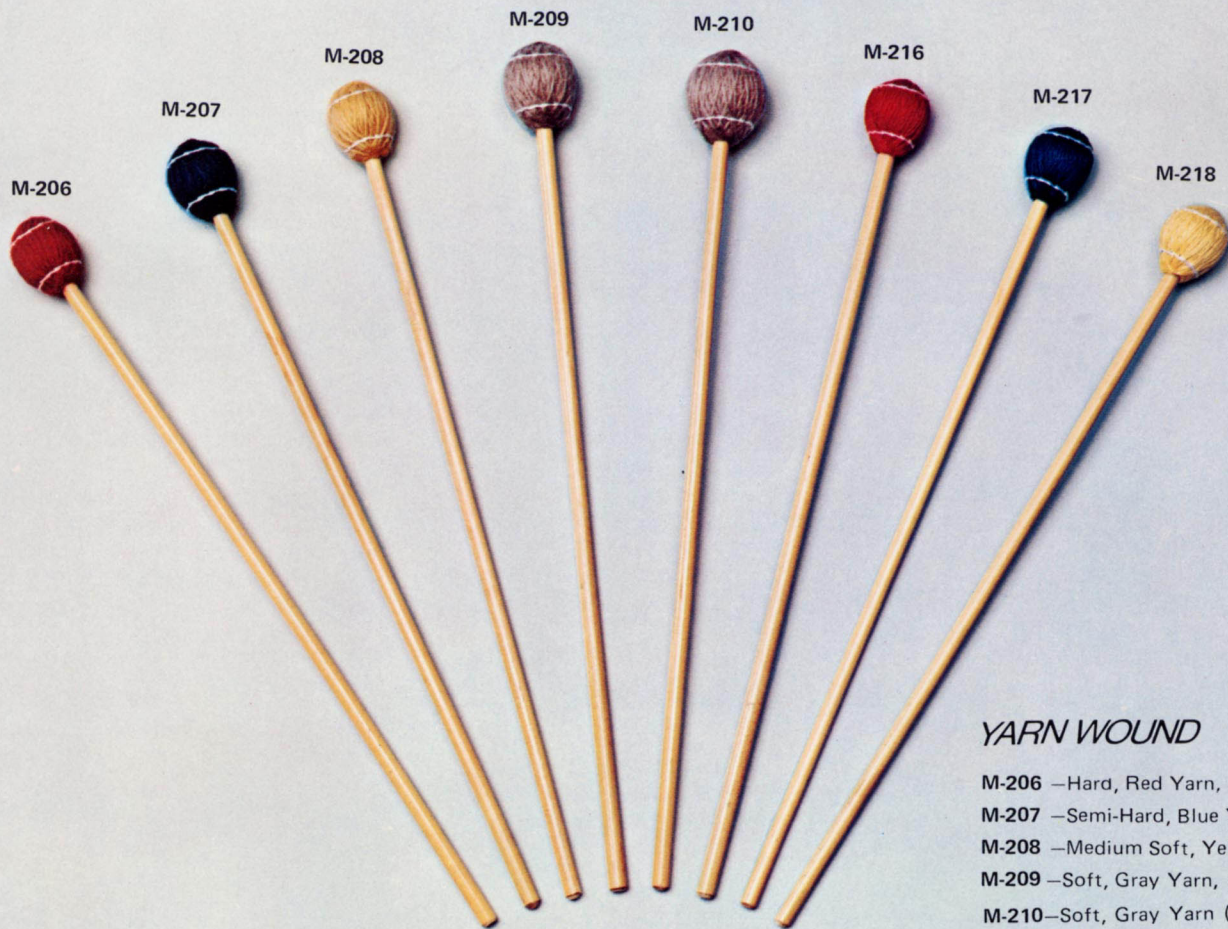

RATTAN HANDLE MALLETS

Add a new look and new feel to your playing with Ludwig's high quality mallets featuring genuine rattan handles. Each mallet is tested for flex with matched pairs selected according to flex and diameter. Check these custom-quality features; mallet heads are of graduated hardness to provide a wide selection of tonal response; choice of 3 cord and 5 yarn wound heads; fine quality rattan handles, pre-packed in pairs.

YARN WOUND

- M-206 —Hard, Red Yarn, pair.
- M-207 —Semi-Hard, Blue Yarn, pair.
- M-208 —Medium Soft, Yellow Yarn, pair.
- M-209 —Soft, Gray Yarn, pair.
- M-210 —Soft, Gray Yarn (larger), pair.

CORD WOUND

- M-216 —Hard, Red Cord, pair.
- M-217 —Medium, Blue Cord, pair.
- M-218 —Soft, Yellow Cord, pair.

CHIME MALLETS



No. M336—RAWHIDE CHIME Mallet, each.



No. M-337—DUAL HEAD CONCERT CHIME Mallet, each.

Gary Burton



SIGNATURE MALLETS



These professional mallets are manufactured to the exacting specifications demanded by Gary Burton - - Down Beat's 3-time "Vibist of the year" award winner. All materials are selected for quality and inspected after each production process to assure high standards of quality control. Handles are genuine rattan and matched for uniformity in flex, balance, weight, thickness, and diameter. Available in choice of soft yarn or medium yarn. Sold in matched pre-packed sets of 4, only.

- M-220—Set of 4 Gary Burton Signature Mallets, Rattan handles, Black Yarn, Soft.
- M-221—Set of 4 Gary Burton Signature Mallets, Rattan Handles, Gold Yarn, Medium.

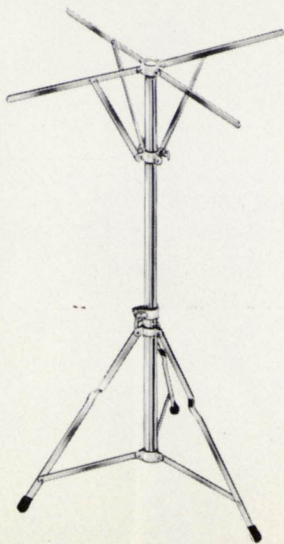

CONCERT BAND BELL STAND

A sturdy, heavy duty, folding stand designed to hold Concert Band Bells in playing position. Also ideal for holding the Piccolo Xylophone. Complete height adjustment accommodates seated or standing positions. Finished in beautiful triple chrome plate for years of service.

No. M1368—CONCERT BAND BELL STAND.

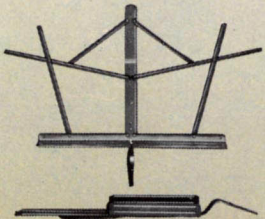

MUSIC RACK

For added convenience in practice and performance add a sturdy music rack to your instrument. Durable in construction and lasting in design the rack mounts right onto most standard mallet instruments and folds when not in use. Available in your choice of brass or nickel plate finishes.

No. M117—MUSIC RACK, brass plate.

No. M118—MUSIC RACK, nickel plate.

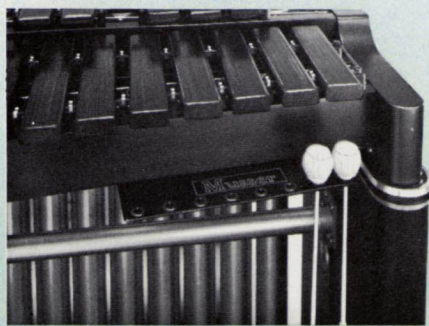

NEW MALLETS HOLDER

Sturdy, heavy-duty metal plate with rubber grommets attaches easily to underside of keyboard rail for convenient accessibility of mallets. Holder also prevents loss of mallets in performance and can be slipped off of instrument when not in use. Holds four pairs of mallets.

M812—MALLETS HOLDER.
No. 527—BAR POLISH
(not illustrated)

NEW TUNING FORKS

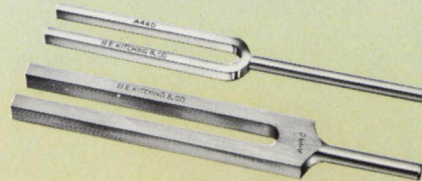

Here are two tuning forks made of tempered metal to meet the demands for high grade, scientific tuning forks for the music industry.

CHROME-PLATED, STEEL TUNING FORKS,
tines: $\frac{3}{16}$ " x $\frac{1}{4}$ ", overall height: $6\frac{1}{2}$ ".

No. 516—A=440 VPS TUNING FORK.

No. 517—B \flat =466.2 VPS TUNING FORK.

No. 518—C=523.3 VPS TUNING FORK.

SATIN-FINISH ALUMINUM TUNING FORK,
tines: $\frac{5}{16}$ " x $\frac{3}{8}$ ", overall height: 7".

No. 519—A=440 VPS TUNING FORK.

No. 520—B \flat =466.2 VPS TUNING FORK.

No. 521—C=523.3 VPS TUNING FORK.

This tuning bar features a spring-mounted rubber bumper which strikes the bar to produce a true tone, thus eliminating the need for a separate mallet. The accurately tuned, $\frac{1}{4}$ " thick x $1\frac{1}{4}$ " wide, brushed aluminum alloy bar is mounted on a precision built, black lacquered birch resonator box.

No. 522—A=440 VPS TUNING BAR.

No. 523—B \flat =466.2 VPS TUNING BAR.

NEW, SELF-CONTAINED TUNING BAR

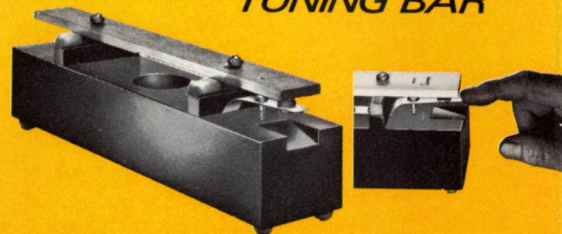

SOUNDED SCALE RANGES

MALLETS PERCUSSION INSTRUMENTS

STANDARD TUNING OF LUDWIG/MUSSER INSTRUMENTS

Marimbas, Vibes and Bell Lyras are tuned to A=440; Xylophones, Orchestra Bells and Chimes are tuned to A=442. If special tuning other than above is desired, specify with order.

Marimbas:

Model No. M250	A ₂ -C ₇
Model No. M150	C ₃ -C ₇
Model No. M30	C ₃ -C ₇
Model No. M31	C ₃ -C ₇
Model No. M61 (M60)	F ₃ -F ₆
Model No. M21 (M20)	C ₄ -F ₆

Vibes:

Model No. M75	F ₃ -F ₆
Model No. M55	F ₃ -F ₆
Model No. M45	F ₃ -F ₆

Orchestra Bells:

Model No. M645	G ₅ -C ₈
----------------	--------------------------------

Xylophone:

Model No. M39	C ₅ -C ₈
Model No. M51 (M50)	F ₄ -C ₈
Model No. M42 (M43)	C ₅ -C ₈
Model No. M41 (M40)	G ₅ -C ₈
Model No. M47 (M44)	C ₅ -C ₈
Model No. M49 (M46)	C ₅ -C ₈

Chimes:

Model No. M635	C ₅ -G ₆
Model No. M630	C ₅ -G ₆

Bell Lyra:

Model No. M2044	A ₅ -A ₇
Model No. M2041	A ₅ -A ₇
Model No. M2040	A ₅ -A ₇

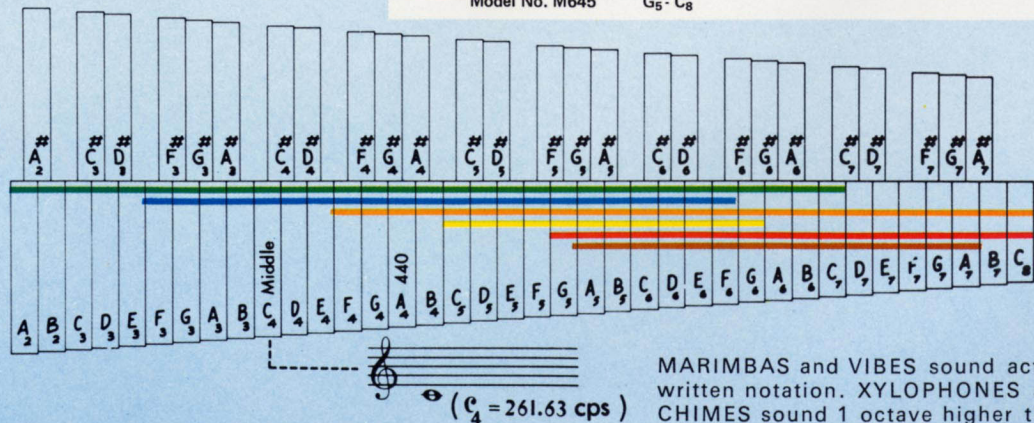

MARIMBAS and VIBES sound actual written notation. XYLOPHONES and CHIMES sound 1 octave higher than written notation. ORCHESTRA BELLS and BELL LYRAS sound 2 octaves higher than written notation.

CONCERT TOM TOMS



445
Fits case Nos. 8565, 8464
See Page 101

(Mahogany Cortex, illustrated)



443
Fits case No. 8362
See Page 101

No. 443P — CONCERT TOM TOMS (High Pitch), Choice of Pearl finishes, complete with clip attachments and stands.

No. 445P — CONCERT TOM TOMS (Low Pitch), Choice of Pearl finishes, complete with clip attachments and stands.

No. 1340 -1 Sturdi-Lok Double Tom Tom Floor Stand with tilter adjustment, complete with clip attachments.

No. 1341 — Heavy Duty Stand for Concert Tom Toms (Not Shown).

No. 1343 — Concert Tom Floor Stand only (holds two toms).

HIGH PITCHED TOM SET:

- 1 No. 487—5½" x 6"
- 1 No. 488—5½" x 8"
- 1 No. 489—6½" x 10"
- 1 No. 461—8" x 12"
- 2 No. 1343 Stand.

LOW PITCHED TOM SET:

- 1 No. 462—9" x 13"
- 1 No. 463—10" x 14"
- 1 No. 464—12" x 15"
- 1 No. 465—14" x 16"
- 2 No. 1343 Stand.

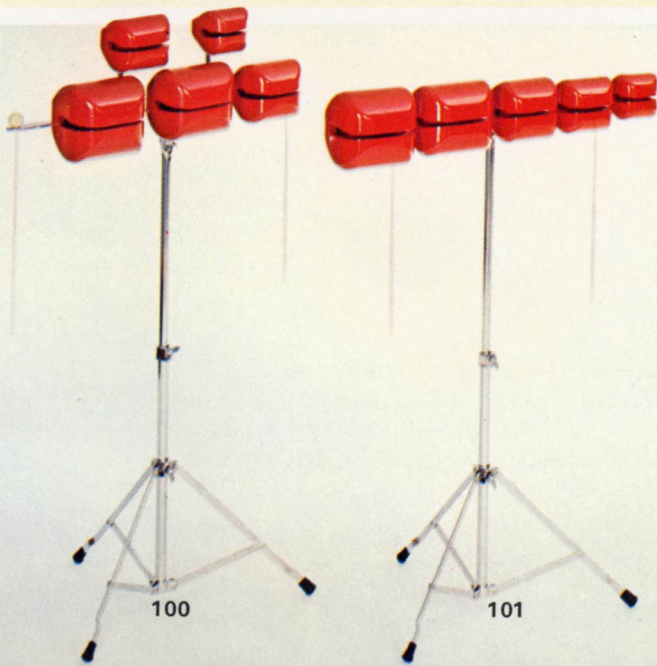

100

101

CONCERT TEMPLE BLOCKS:

Ludwig now offers two separate sets of 5 graduated CONCERT TEMPLE BLOCKS, in lacquer finish mounted on your choice of chrome plated stand with "staggered" or "in-line" arms as illustrated. Sold complete as listed; however, items may be purchased separately. Supplied with one pair of suitable mallets.

No. 100 — CONCERT TEMPLE BLOCKS and stand with staggered arms, illustrated.

No. 101 — CONCERT TEMPLE BLOCKS and stand with "in-line" arms, illustrated.

No. 1347—Temple Block Stand with staggered arms.

No. 1342—Temple Block Stand with "in-line" arms.

No. 80 —Set of 5 Temple Blocks with mallets.

No. M 1 —Mallets, pair

INDIVIDUAL TEMPLE BLOCKS:

- No. 691—5"
- No. 692—4½"
- No. 693—4"
- No. 694—3½"
- No. 695—3"

LUDWIG CONCERT BASS DRUMS

The famous LUDWIG line of concert bass drums has long been the choice of leading musical organizations the world over. Acoustically designed shells offer superior tone and response. Matched heads, self-aligning tension casings, solid counter hoops and the finest in finishes are all extra value features. Triple chrome-plating on all hardware assures lasting beauty.

SPECIFICATIONS:

Ludwig "SYMPHONIC STYLE" concert bass drums are built to professional standards and are available in a wide range of sizes. The popular 16" x 36" size is recommended for most concert work. All models available in choice of pearl finishes with bright glistening "triple" chrome-plated hardware.

No. 801P — 14" x 28" Choice of Pearl finishes.

No. 802P — 14" x 30" Choice of Pearl finishes.

No. 804P — 16" x 32" Choice of Pearl finishes.

No. 805P — 16" x 34" Choice of Pearl finishes.

No. 806P — 16" x 36" Choice of Pearl finishes.

No. 807P — 18" x 36" Choice of Pearl finishes.

No. 808P — 18" x 40" Choice of Pearl finishes.



(Mahogany Cortex Illustrated)



THE IMPERIAL HIGH TENSION CASING

The beautifully styled self-aligning tension casings are precision engineered to evenly distribute head tension within itself, thus eliminating excessive stress on the shell.

CONCERT BASS DRUM FOLDING STAND

This chrome plated tubular stand offers a concert bass drum sturdy support. It has ample bumper protection and is adjustable for varying the height of a bass drum's position in use, vertical or horizontal.

No. 790—FOLDING BASS DRUM STAND
for 28" to 36" diameter drums,
illustrated.

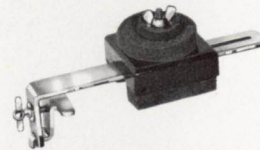

BASS DRUM CYMBAL HOLDER

Holds cymbal securely on bass drum for combination bass drum and cymbal playing. Attaches to bass drum hoop.

No. 357—BASS DRUM CYMBAL HOLDER.

FREE SUSPENSION CONCERT BASS DRUM STAND

...offering complete angle adjustment

Ludwig now offers the ultimate in concert bass drum stands. In addition to offering complete angle adjustment, the stand provides for complete suspension of the bass drum. This unique feature allows the performer to obtain full resonance from his instrument at all dynamic levels. Free suspension means greater projection of sound with less playing effort. Even complex staccato passages can be effectively played with little difficulty. Heavy Duty Stand features complete angle adjustment and 4 large coaster wheels.

No. 789 -SUSPENDED BASS DRUM STAND
for 32" to 40" diameter drums.
(Note: Specify drum diameter when
ordering stand separately.)

FULL DROP BASS DRUM COVER



Protect valuable concert bass drums with a full drop cover made of heavy duty material. Designed for use with the Ludwig Suspended Bass Drum Stand.

No. 639 -FULL DROP BASS DRUM COVER
for suspended bass drum stand.



Pat No. 3780613

LUDWIG BASS DRUM CARRIAGE

Compact, lightweight and highly maneuverable, Ludwig's bass drum carriage makes it possible to obtain the concert tone of a large bass drum on the march. Designed to fit any size from 14" x 28" on up, carriage may be pulled for player or is easily pushed by the player himself.

No. 791 -BASS DRUM CARRIAGE.

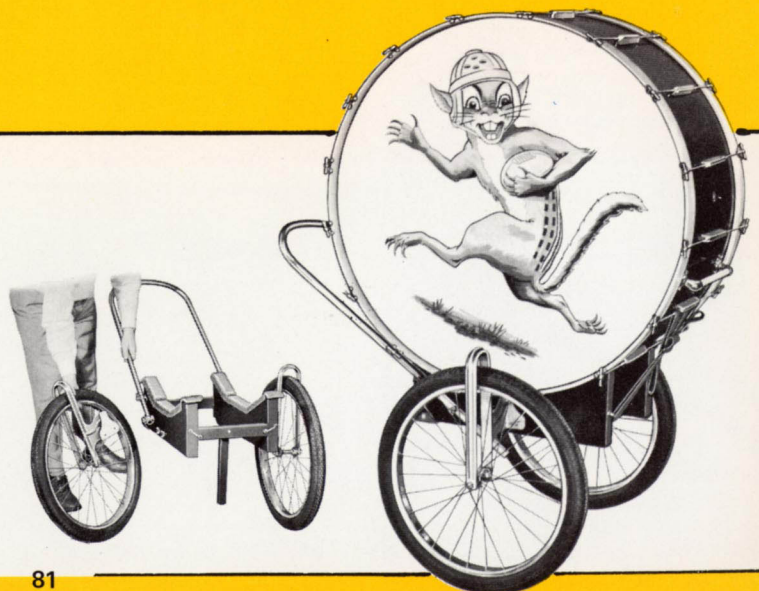

CYMBALS

AVEDIS ZILDJIAN CYMBALS



- No. 1710 - 10" A. Zildjian Cymbal, each
- No. 1712 - 12" A. Zildjian Cymbal, each
- No. 1714 - 14" A. Zildjian Cymbal, each
- No. 1716 - 16" A. Zildjian Cymbal, each

LUDWIG maintains a complete stock of the most popular sizes of world famous AVEDIS ZILDJIAN Cymbals. Please specify weight using the following suffixes after the number designation: T-Thin, M-Medium, H-Heavy. Rivets can be added to any size and weight cymbal below at an extra charge. Non-returnable after rivets have been installed.

- No. 1718 - 18" A. Zildjian Cymbal, each
- No. 1720 - 20" A. Zildjian Cymbal, each
- No. 1722 - 22" A. Zildjian Cymbal, each
- No. 1724 - 24" A. Zildjian Cymbal, each

NEW BEAT HI-HAT CYMBALS

Avedis Zildjian NEW BEAT Hi-hats consist of two different weight cymbals. The medium weight top Hi-hat cymbal is mated to a specially designed heavy bottom. Packaged in pairs by the Zildjian factory.

- No. 1734 - 14" New Beat Hi-hats, pair

- No. 1735 - 15" New Beat Hi-hats, pair

MINI - CUP RIDE CYMBALS

- No. 1738 - 18" Mini-Cup Cymbal, each

- No. 1739 - 20" Mini-Cup Cymbal, each

CONCERT CYMBALS

Available in three tonal categories. Please specify weight using the following suffixes after the number designation: T-Thin(French), M-Medium (Viennese), H-Heavy (Wagnerian).

- No. 1740 - 18" Concert Cymbal, pair

- No. 1742 - 20" Concert Cymbal, pair

MARCHING CYMBALS

Packaged in matched pairs by the Zildjian factory with grommets.

REGULAR MARCHING

- No. 1754 - 14" Marching, pair
- No. 1755 - 15" Marching, pair
- No. 1756 - 16" Marching, pair
- No. 1758 - 18" Marching, pair
- No. 1760 - 20" Marching, pair
- No. 1762 - 22" Marching, pair
- No. 1764 - 24" Marching, pair

BRILLIANT MARCHING

- No. 1774 - 14" Brilliant Marching, pair
- No. 1775 - 15" Brilliant Marching, pair
- No. 1776 - 16" Brilliant Marching, pair
- No. 1778 - 18" Brilliant Marching, pair
- No. 1780 - 20" Brilliant Marching, pair
- No. 1782 - 22" Brilliant Marching, pair
- No. 1784 - 24" Brilliant Marching, pair

Other sizes and types of Zildjian Cymbals can be made available. Prices and specifications on request.

LUDWIG STANDARD CYMBALS

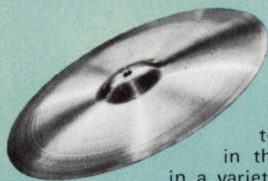

The LUDWIG STANDARD Cymbal line offers high-quality tone, resonance and response. These cymbals are carefully crafted by cymbal manufacturing experts to provide the best quality cymbals possible in the medium price range. They are available in a variety of sizes and weights to meet the requirements of almost any need. Please specify weight using the following suffixes after the number designation: T-Thin, M-Medium, H-Heavy. When ordering concert hand cymbals, list individually and indicate weight desired. Concert cymbals are not listed in pairs.

- No. 210 - 10", each
- No. 212 - 12", each

- No. 214 - 14", each
- No. 216 - 16", each

- No. 218 - 18", each
- No. 220 - 20", each
- No. 222 - 22", each

Rivets can be added to any size and weight cymbal above at an extra charge. Non-returnable after rivets have been installed.

HI - HAT CYMBALS

(Product No. for pairs only.)

- No. 214-HH - 14", pair.
- No. 215-HH - 15", pair.

MARCHING CYMBALS

(Product No. for pairs only.)

- No. 214-MA - 14", pair.
- No. 216-MA - 16", pair.
- No. 218-MA - 18", pair.

TAM-TAMS

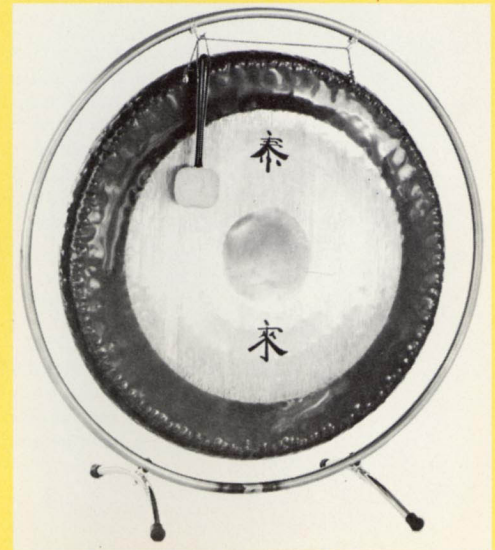

SYMPHONIC TAM-TAMS

Each tam-tam is tempered and hand hammered from special metals with delicate care and superb craftsmanship. The musical quality of these tam-tams is beyond compare. . . no musical organization is quite complete without several of various sizes and tonal colors. One suitable mallet is supplied with each tam-tam at no additional cost.

- No. 753 - 20" Diameter
- No. 757 - 30" Diameter
- No. 768 - 22" Diameter
- No. 758 - 32" Diameter
- No. 754 - 24" Diameter
- No. 769 - 34" Diameter
- No. 755 - 26" Diameter
- No. 767 - 36" Diameter
- No. 756 - 28" Diameter
- No. 759 - 38" Diameter

TAM-TAM STANDS

Full steel circle for rigid support with modern curved feet mounted on circle with new non-twist brackets for maximum stability. Non-slip rubber tips provide firm anchorage. Adjustable hooks allow centering of tam-tam in stand for balanced weight distribution.

- No. 764 - Tam-Tam Stand for sizes 20" to 24"
- No. 762 - Tam-Tam Stand for sizes 26" to 30"
- No. 763 - Tam-Tam Stand for sizes 32" to 40"

LUDWIG[®] cymbal, gong and tam-tam accessories

GONG/ TAM- TAM MALLETS



Ludwig presents a complete line of gong mallets which are specifically designed to produce the ideal tone quality from any given gong size. Lamb's wool or top quality felt heads are mounted on strong wooden handles.

- No. 362—MALLET FOR 32" TO 38" GONG /TAM-TAM
Lamb's Wool
- No. 329—MALLET FOR 26" TO 30" GONG/TAM-TAM
Lamb's Wool
- No. 363—MALLET FOR 24" GONG /TAM-TAM
Lamb's Wool
- No. 364—MALLET FOR 32" TO 38" GONG/TAM-TAM
Gray Felt
- No. 365—MALLET FOR 24" TO 30" GONG/TAM-TAM
Gray Felt
- No. 366—MALLET FOR 20" GONG /TAM-TAM
Gray Felt

DELUXE GONG/ TAM- TAM MALLET

Ludwig offers a deluxe, special gong mallet that is properly weighted to bring out the deep, rich tone of the gong. Supplied with Lamb's wool head on chrome-plated steel handle.

- No. 326—DELUXE
GONG /TAM-TAM MALLET

LAMB'S WOOL CYMBAL HOLDER

A deluxe lamb's wool cymbal pad with leather thongs. Easy on the hands while providing perfect cymbal action.

- No. 1365—CYMBAL
HOLDERS, pair.

LEATHER THONGS

Sturdy, yet soft and flexible, these leather thongs perform perfectly in concert use when tied to the cymbals. These are traditionally the ideal holders for minimum muting of the cymbal sound.

- No. 1366—LEATHER THONG,
each.

WOOD HANDLE CYMBAL HOLDERS

A solid, hard wood handle that bolts to the cymbal. Plastic loop provides a sure grip.

- No. 358—WOOD HANDLE
CYMBAL HOLDERS, pair.

PLASTIC CYMBAL HOLDERS

Leather thongs with plastic pads provide the ideal holder for good cymbal response and tone.

- No. 1367—PLASTIC CYMBAL
HOLDERS, pair.

METAL POLISH

Ludwig's metal polish is specifically formulated to protect cymbals and to keep them new looking for lasting beauty.

- No. 528—METAL
POLISH.

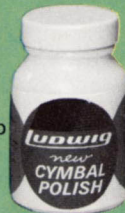

CYMBAL CLEANER

Ideal for keeping cymbals clean and new looking for years. This new formula keeps cymbals gleaming without any scratching or marring.

- No. 530—CYMBAL CLEANER



TAM- TAM COVERS



Full drop, fleece lined covers provide maximum protection of tam-tams from dust and damage. Also, they discourage misuse when tam-tams are not being played in practice or performance.

- No. 764-1 —TAM-TAM COVER
FOR NO. 764 STAND.
- No. 762-1 —TAM-TAM COVER
FOR NO. 762 STAND.
- No. 763-1 —TAM-TAM COVER
FOR NO. 763 STAND.

ZIPPER CYMBAL POUCH



Here is an extremely NEW design in cymbal pouches. Sturdy, leatherette finish, attractively stitched with zipper opening. Completely dustproof. Convenient to carry on the march.

- No. 1387—18" DIA. ZIPPER
LEATHERETTE CYMBAL
POUCH.
- No. 1389—24" DIA.

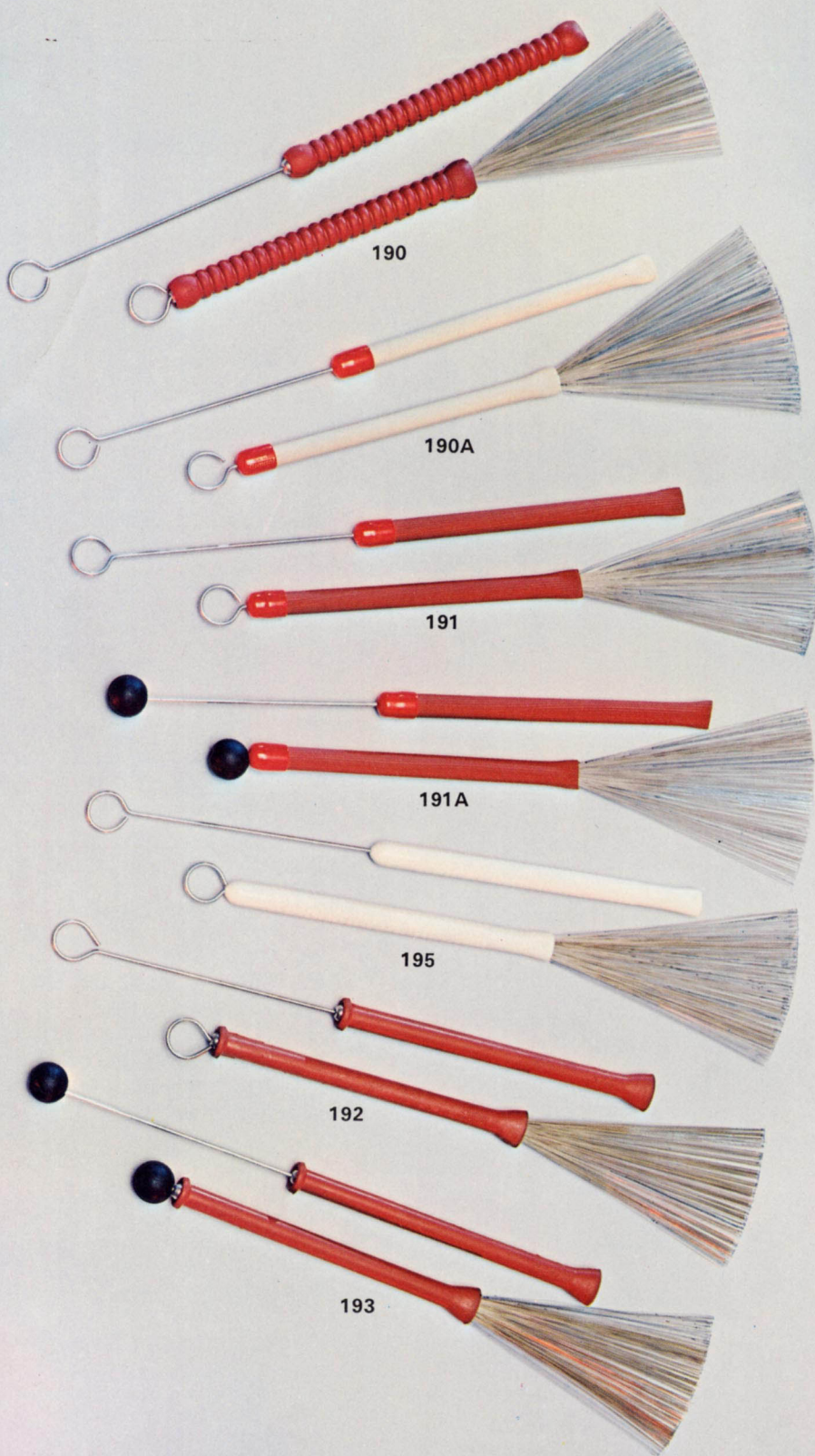

Ludwig offers the largest and most complete line of wire brushes available today. This wide selection provides each player with THE brush for his particular needs. Each model has been carefully designed for correct balance and is constructed of only the finest materials. Wires will not drop out and are machine-fanned to the proper width. Follow the top professionals—select your favorite model from the quality line of Ludwig brushes.

No. 190—RED RIBBED MODEL

Handle is molded approximately to same diameter as the average dance model drum stick. Deep ribs prevent slipping or turning while in use and provide added weight for cymbal work.

No. 190—RED RIBBED MODEL, pair.

NO. 190A—WHITE RUBBER MODEL

Here's the most popular of all! Small, smooth white rubber handle especially designed for circular press rolls and small combo work.

No. 190A—WHITE RUBBER MODEL, pair.

NO. 191—RED GROOVED MODEL

A favorite among top drum stars. Grooves prevent turning while in use. Slim handle fits comfortably between fingers.

No. 191—RED GROOVED MODEL, pair.

NO. 191A—BALL END GROOVED MODEL

Grooved red rubber handle prevents turning while in use. Ball end is designed for cymbal and tom tom use.

No. 191A—BALL END GROOVED MODEL, pair.

NO. 195—WHITE PLASTIC MODEL

The new white plastic model provides a sure-grip, slim handle designed for solid rim shot work.

No. 195—WHITE PLASTIC MODEL, pair.

NO. 192—MOLDED RED RUBBER MODEL

A fine performing model with molded form-fitting rubber handle that will not slip in use. Live rubber handle is ideal for cymbal work.

No. 192—MOLDED RED RUBBER MODEL, pair.

NO. 193—BALL END MOLDED MODEL

Molded red rubber handle with ball end for cymbal and tom tom use. Thick flange at end provides solid sock beats.

No. 193—BALL END MOLDED MODEL, pair.

Ludwig T.M.
standard

**OAKWOOD DRUMSTICKS
FINE QUALITY**

LUDWIG'S NEW LINE of oak drum sticks is manufactured from select grade oakwood, carefully finished to a high luster. Available in twelve popular models in wood tip, the oak stick is made to the same specifications as Ludwig's top quality HICKORY models. Packaged in open end poly bags.

**OAKWOOD/NYLON TIP
DRUM STICKS**

All Ludwig Standard oak sticks are offered with nylon tips with the exception of the 3SO model. Please specify catalog numbers as listed below:

Small Nylon Tip

- 2AON
- 3AON
- 5AON
- 7AON
- 8AON
- 9AON
- 10AON
- 11AON



Large Nylon Tip

- 2BON
- 5BON
- 2SON

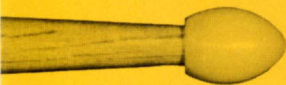

No. 2AO Medium olive bead, medium neck, moderately short shoulder taper, length: 15 3/4" x 5/8" diameter.

No. 3AO Small ball bead, moderately thin neck, moderately long shoulder taper, length: 15 5/8" x 9/16" diameter.

No. 5AO Medium olive bead, thin neck, moderately long should taper, length: 16" x 9/16" diameter.

No. 7AO Medium olive bead, thin neck, moderately short shoulder taper, length: 15 1/4" x 1/2" diameter.

No. 8AO Acorn bead, thin neck, long shoulder taper, length: 15 7/8" x 1/2" diameter.

No. 9AO Moderately large olive bead, medium neck, short shoulder taper, length: 15 3/4" x 5/8" diameter.

No. 10AO Moderately large olive bead, medium neck, long shoulder taper, length: 15 7/8" x 1/2" diameter.

No. 11AO Medium olive bead, moderately thin neck, moderately short shoulder taper, length: 15 5/8" x 1/2" diameter.

No. 2BO Medium olive bead, medium neck, short shoulder taper, length 15 7/8" x 5/8" diameter.

No. 5BO Moderately large olive bead, medium neck, moderately long shoulder taper, length: 16" x 9/16" diameter.

No. 2SO Large ball bead, thick neck, short shoulder taper, length 17" x 11/16" diameter.

No. 3SO Very large ball bead, very thick neck, moderately long shoulder taper, length: 16 7/8" x 3/4" diameter.

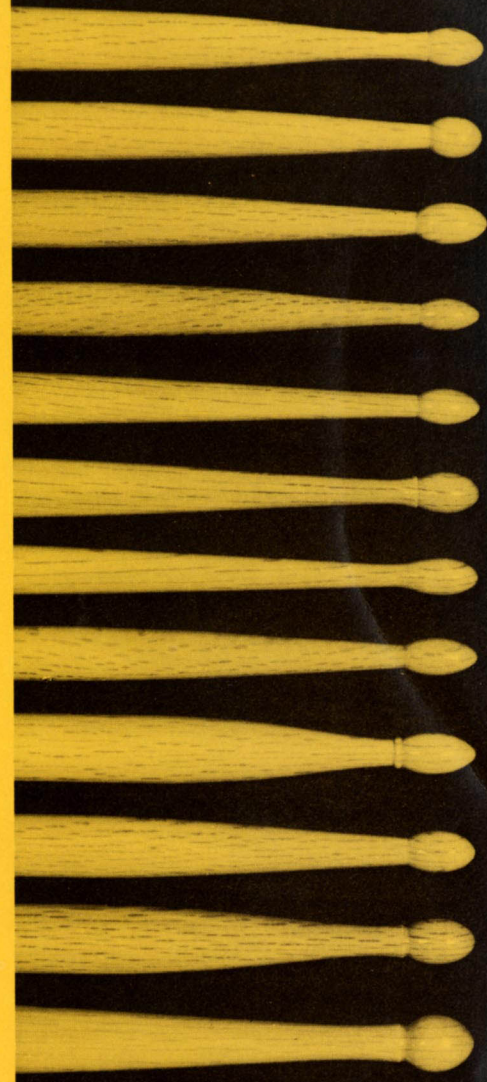

LUDWIG
McCORMICK

**CUSTOM DRUM
MALLET LINE
FEATURING PATENTED
ADJUSTA BALANCE**



LUDWIG/McCORMICK MALLETS are the choice of today's leading Drum Corps. They have the new look, new feel, and new sound for tomorrow's Champions. And most important is ADJUSTA-BALANCE, the patented construction that makes LUDWIG/McCORMICK mallets uniquely fit your individual playing techniques. ADJUSTA-BALANCE mallets are adjustable by you to the particular balance you prefer. Constructed of the very finest materials,

4200. .ADJUSTA-BALANCE TENOR MALLET (WOOD)—Our very first tenor mallet. Equipped with wooden heads for clean articulation and is complete with balance plugs.

4201. .ADJUSTA-BALANCE TENOR MALLET (FELT)—A slightly softer quality is produced from these mallets. Felt heads, complete with balance plugs.

4202. .DUAL END ADJUSTA-BALANCE TENOR MALLET—This was designed for the corps that wanted both an articulate wooden head as well as the softer tones produced by the felt head.

4210. .DUAL END TIMP TOM OR TIMPANI MALLET—Dual end Adjusta-Balance mallet for softer tones. One side is a soft sewn felt head with the other a more articulate hard felt.

4211. .SOFT HEADED TIMPANI MALLET—A sewn felt headed timp mallet with Adjusta-Balance. May be used on Timp Toms also.

4220. .RUDIMENTAL ADJUSTA-BALANCE BASS MALLET—This is our Adjusta-Balance bass mallet. It comes with wooden heads, balance plugs, and bright gold shafts. Very articulate.

4221. .RUDIMENTAL-BASS MALLET (WOOD)—Our very popular bass mallet ideal for rudimental bass drumming. Has non-slip grip and beautiful walnut stained finish.

4222. .MEDIUM HEAD BASS MALLET (FELT)—Used for tuned or pitched bass drums as well as for a less articulate rudimental bass drum. Has our non-slip handle and walnut stained finish.

4223. .LARGE HEAD BASS MALLET (FELT)—This new mallet designed for the large bass drum, completes the bass drum line. It has a large but sturdy felt head.

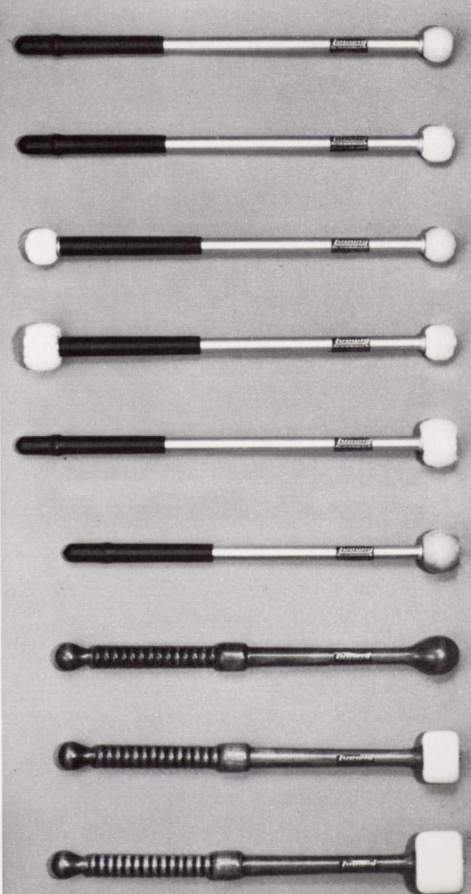

LUDWIG *matched snare drum sticks*

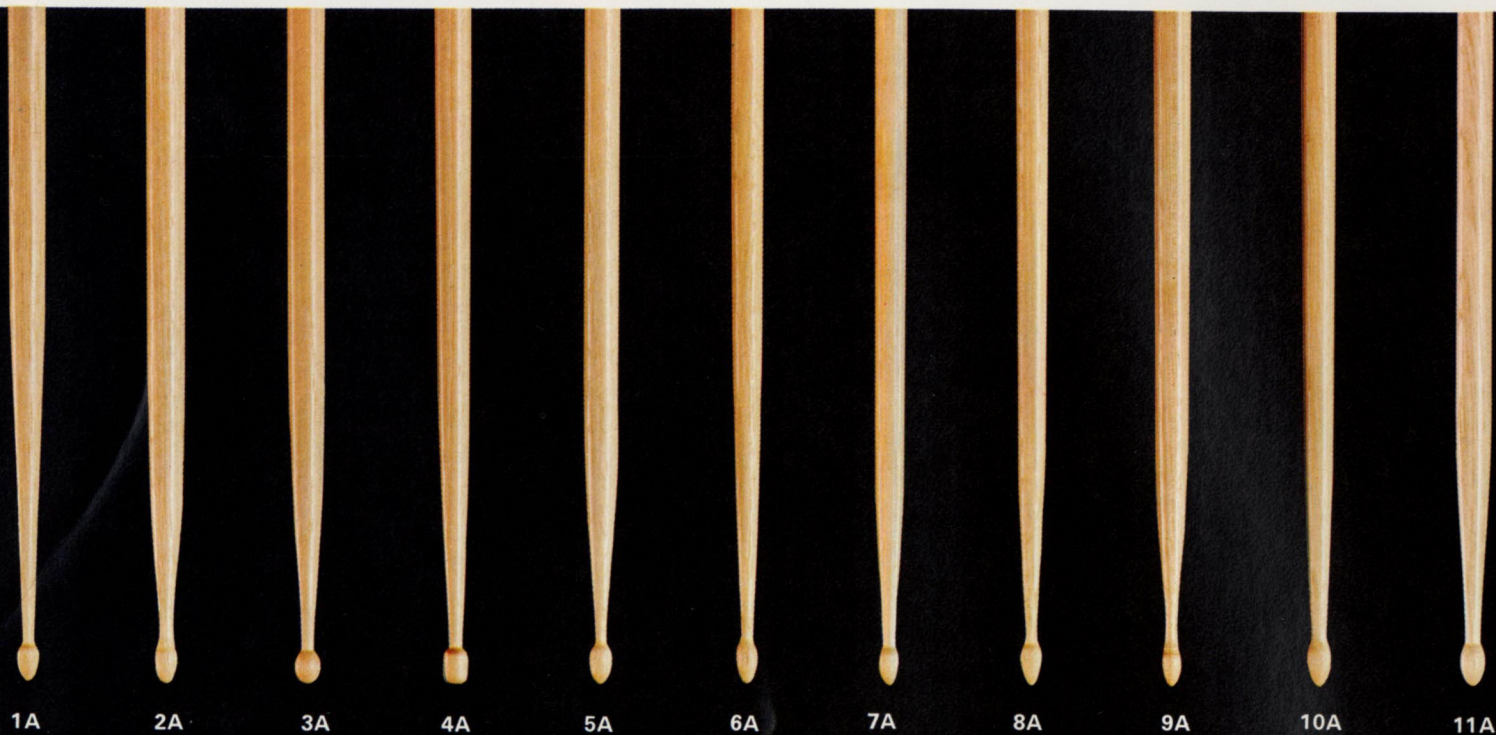

HICKORY STICKS

Ludwig hickory snare drum sticks are cut from select close-grained hickory dowels, carefully sanded, filled, properly identified and satin lacquer finished. Sticks are checked for defects before being paired and sealed in air-tight plastic bags. Bead shape, neck thickness, shoulder taper, stick length and shaft diameter are approximate.

MODEL NUMBERS AND DESCRIPTION

- No. 1A** —Acorn bead, thin neck, long shoulder taper, length 16 $\frac{1}{4}$ " x $\frac{3}{16}$ " diameter.
- No. 2A** —Medium olive bead, medium neck, moderately short shoulder taper, length 15 $\frac{3}{4}$ " x $\frac{5}{16}$ " diameter.
- No. 3A** —Small ball bead, moderately thin neck, moderately long shoulder taper, length 15 $\frac{5}{8}$ " x $\frac{9}{16}$ " diameter.
- No. 4A** —Capsule bead, medium neck, long shoulder taper, length 15 $\frac{5}{8}$ " x $\frac{9}{16}$ " diameter.
- No. 5A** —Medium olive bead, thin neck, moderately long shoulder taper, length 16" x $\frac{9}{16}$ " diameter.
- No. 6A** —Small olive bead, thin neck, long shoulder taper, length 15 $\frac{1}{2}$ " x $\frac{3}{8}$ " diameter.
- No. 7A** —Roy Haynes model, medium olive bead, thin neck, moderately short shoulder taper, length 15 $\frac{1}{4}$ " x $\frac{1}{2}$ " diameter.
- No. 8A** —Acorn bead, thin neck, long shoulder taper, length 15 $\frac{7}{8}$ " x $\frac{3}{8}$ " diameter.
- No. 9A** —Moderately large olive bead, medium neck, short shoulder taper, length 15 $\frac{3}{4}$ " x $\frac{5}{8}$ " diameter.
- No. 10A** —Ray McKinley model, moderately large olive bead, medium neck, long shoulder taper, length 15 $\frac{3}{4}$ " x $\frac{1}{2}$ " diameter.

NYLON TIPS

All Ludwig stick models except No. 4S and No. 7B are available with nylon tips at additional cost;

**When ordering, specify "N" after the model number.*

Nylon tips are supplied in three sizes to correspond with the "A", "B" and "S" models.

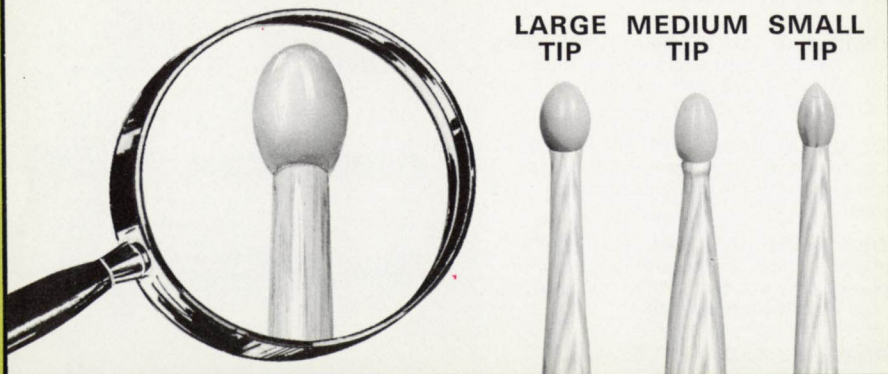

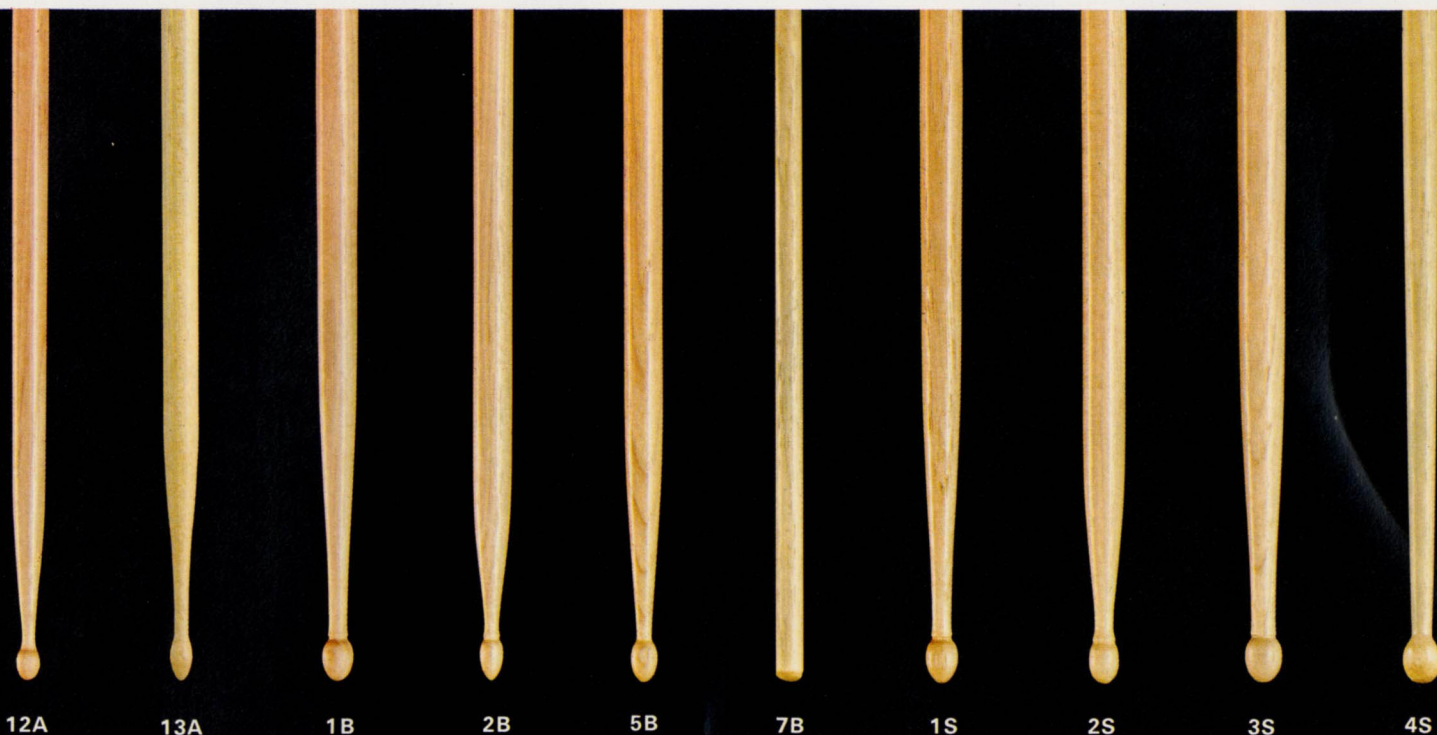

No. 11A—Joe Morello model, medium olive bead, moderately thin neck, moderately short shoulder taper, length $15\frac{5}{8}$ " x $\frac{1}{2}$ " diameter.

No. 12A—Jo Jones model, acorn bead, thin neck, short shoulder taper, length $14\frac{3}{4}$ " x $\frac{9}{16}$ " diameter.

No. 13A—Medium large olive bead, medium neck, moderately long shoulder taper, length $15\frac{1}{2}$ " x $\frac{9}{16}$ " diameter.

No. 1B—Moderately large ball bead, moderately thick neck, long shoulder taper, length $16\frac{7}{8}$ " x $\frac{5}{8}$ " diameter.

No. 2B—Medium olive bead, medium neck, short shoulder taper, length $15\frac{7}{8}$ " x $\frac{5}{8}$ " diameter.

No. 5B—Moderately large olive bead, medium neck, moderately long shoulder taper, length 16 " x $\frac{9}{16}$ " diameter.

No. 7B—Rock Beat model, length 16 " x $\frac{1}{2}$ " diameter.

No. 1S—Large olive bead, moderately thick neck, long shoulder taper, length $16\frac{7}{8}$ " x $\frac{5}{8}$ " diameter.

No. 2S—Large ball bead, thick neck, short shoulder taper, length 17 " x $\frac{1}{4}$ " diameter.

No. 3S—Very large ball bead, very thick neck, moderately long shoulder taper, length $16\frac{7}{8}$ " x $\frac{3}{4}$ " diameter.

No. 4S—Swiss model, length $16\frac{7}{8}$ " x $\frac{3}{4}$ " diameter.

DRUM SIZES AND SUGGESTED STICK MODELS

3" x 13": 6A and 8A
 4" x 14": 7A, 10A and 11A
 5" x 14": 3A, 4A, 5A, 12A, 13A and 5B
 6½" x 14": 1A, 2A, 9A, 1B, 2B and 7B
 10" x 14" and 8" x 15": 1B, 2B, and 1S
 12" x 15" and 12" x 16": 1S, 2S, 3S and 4S

Any of the above stick models can be used on a larger size drum than suggested, and vice-versa.

Select the proper sticks in relation to the size of the drum and the performance activity. For beginners, sticks should be chosen to fit the size of the hand.

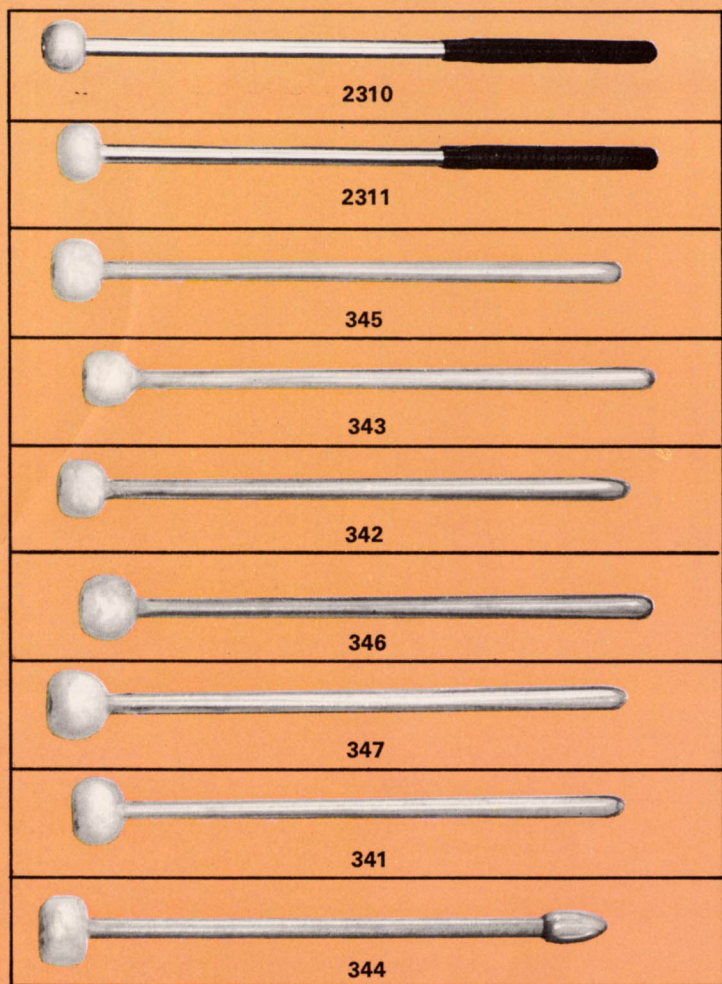

TIMPANI MALLETS

- No. 2310—Hard wood ball end, acrolite shaft, moulded grip, per pair.
- No. 2311—Piano felt sack type end, medium-hard, acrolite shaft, moulded grip, per pair.
- No. 345 —Hard felt ball end, medium, wooden shaft, per pair.
- No. 343 —Piano felt ball end, hard, wooden shaft, per pair.
- No. 342 —Piano felt ball end, medium-hard, wooden shaft, per pair.
- No. 346 —Piano felt ball end, medium-soft, wooden shaft, per pair.
- No. 347 —Piano felt ball end, soft, wooden shaft, per pair.
- No. 341 —Piano felt cartwheel end, Metzenger model, wooden shaft, per pair.
- No. 344 —Piano felt cartwheel end with wooden pear end handle, wooden shaft, per pair.

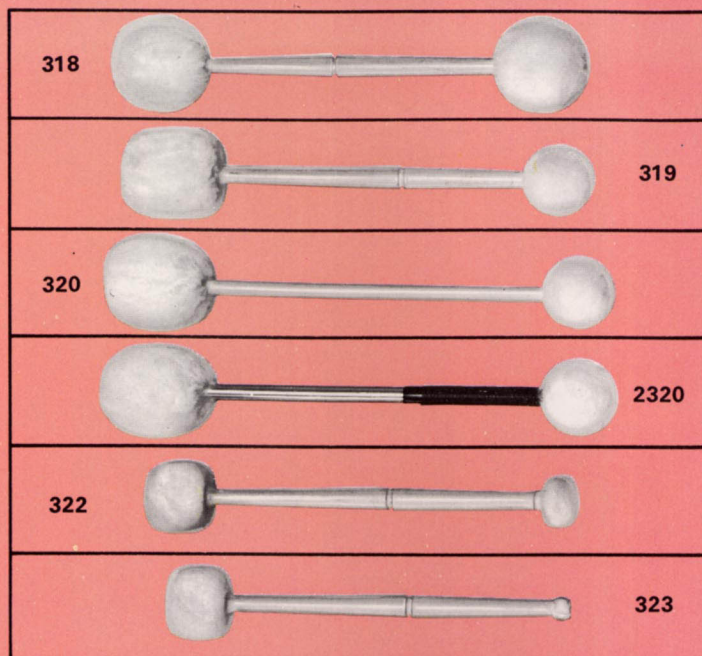

BASS DRUM BEATERS

- No. 318 —Balanced double ball end beater, lambs wool, wooden shaft.
- No. 319 —Large and small double end beater, lambs wool, short tapered wooden shaft.
- No. 320 —Large and small double ball end beater, straight wooden shaft.
- No. 2320—Large and small double ball end beater, lambs wool, acrolite shaft, moulded grip
- No. 322 —Large and small double ball end beater, hard felt, short tapered wooden shaft.
- No. 323 —Large single ball end beater, short tapered wooden shaft.

GENERAL INFORMATION

Ludwig mallets, beaters and sticks for timpani, timpani, bass drums, and tenor drums are made from only the finest materials selected for durability and crafted in the Ludwig quality tradition. Piano felt mallets and lambs wool beaters are hand sewn by experts of long experience and are balanced for tonal response.



... marching mallets, beaters and sticks

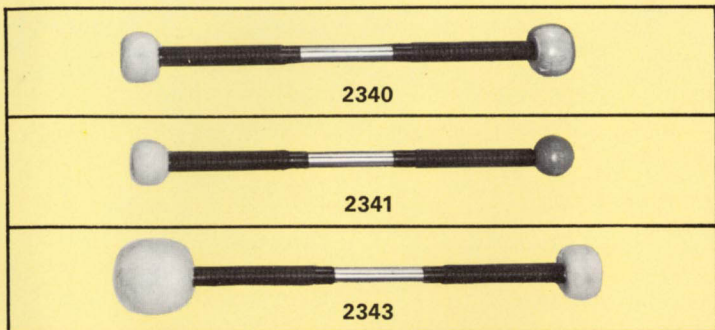

TIMP-TOM MALLETS

- No. 2340—Large, double ball end beaters, wood and felt, acrolite shaft, moulded grip, per pair
- No. 2341—Medium, double ball end beaters, wood and felt, acrolite shaft, moulded grip, per pair
- No. 2343—Large, double ball end beaters, lambs wool and felt, acrolite shaft, moulded grip, per pair.



BASS DRUM BEATERS

- No. 323S —Hard felt, ball end beater, wooden shaft with strap.
- No. 2323S—Hard felt, ball end beater, acrolite shaft with strap.
- No. 334 —Solid wood beaters, per pair.
- No. 2321 —Wooden ball end beaters, acrolite shaft, moulded grip, per pair.
- No. 2322 —Hard felt ball end beaters, acrolite shaft, moulded grip, per pair.
- No. 2331 —Medium-hard felt, ball end beaters, acrolite shaft with thongs, moulded grip, per pair.
- No. 331 —Medium-hard felt, ball end beaters, wooden shaft with thongs, per pair.
- No. 335 —Beater Thongs, pair (not shown) .

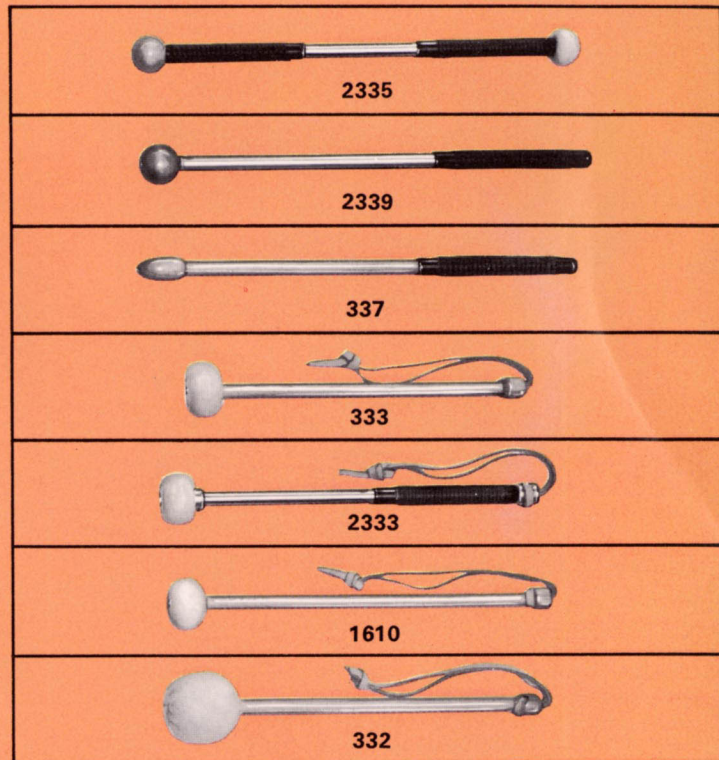

TENOR DRUM STICKS

- No. 2335—Small double ball end beaters, wood and felt, acrolite shaft, moulded grip, per pair.
- No. 2339—Wooden ball end beaters, medium, acrolite shaft, moulded grip, per pair.
- No. 337 —Wooden pear end beaters, small, wooden shaft, per pair.
- No. 333 —Medium felt ball beaters, wooden shaft with thongs, per pair.
- No. 2333—Medium felt ball beaters, acrolite shaft with thongs, per pair.
- No. 1610—Large felt ball beaters, wooden shaft with thongs, per pair.
- No. 332 —Lambs wool beaters, wooden shaft with thongs, per pair.

LUDWIG *practice drum pads... stands...and holders*



FAMOUS GLADSTONE PAD

Made of pure rubber with steel plate imbedded to make an integral structure. This resilient pad does not harden, crack or soften. It provides a crisp, live natural drum rebound; two playing surface levels for rim shot, timbales and tom-tom practice. Patented structure establishes a vacuum, holding pad firmly in place on batter head of your snare drum or table. Supplies adequate volume, audible snare response and excellent control.

No. 351—GLADSTONE PAD.

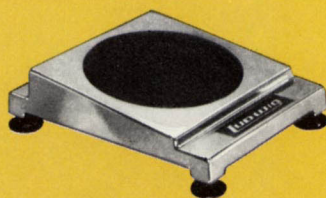

ALL-METAL PRACTICE PAD

Solid one-piece aluminum with thick, live gum rubber set into playing surface. New suction cup feet provide solid anchor to any surface.

No. 355—METAL PAD.

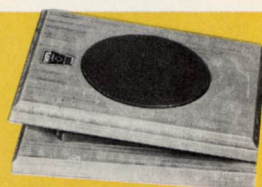

HEAVY DUTY WOOD PAD

Constructed of select hard woods with thick, live gum rubber set into playing surface. Provides proper stick rebound for years of satisfied service.

No. 355W—HEAVY DUTY PAD.

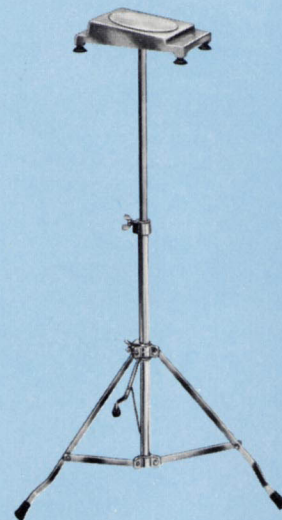

ALL-METAL PAD AND ADJUSTABLE STAND

A convenient practice arrangement using the No. 355 pad mounted on height adjustable stand. Pad is easily detachable, stand folds for packing.

No. 2010-1—NO. 355—PAD AND STAND complete.

No. 1359-1—STAND ONLY for No. 355 Pad.

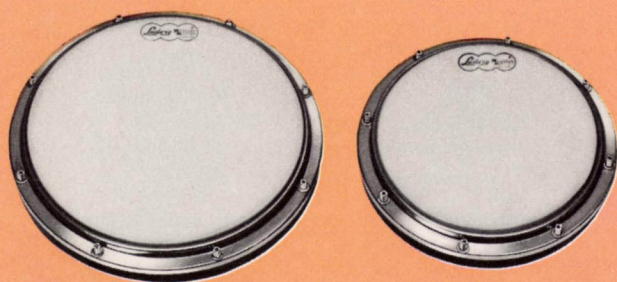

NEW TUNABLE PRACTICE PADS

The very latest in modern design that can be tuned to any desired tension with any standard drum key. They can be used for either stick or brush and provide the touch, feel and rebound of an actual drum. Made of top quality, Weather Master Mylar plastic heads, mounted over a 1" compressed rubber sound insulator with a chrome-plated counter hoop. Rubber bumpers on the solid hardwood base keep the pad from creeping when used on any flat surface. Special insert is imbedded in the base for mounting on floor stand. Select 8" or 10" diameter sizes; replacement heads available.

No. 378—8" TUNABLE PAD.

No. 379—10" TUNABLE PAD.



ALL-RUBBER PORTO PAD

A handy pocket size practice pad of molded top grade gum rubber. Ideal for use on head of drum. Easy to carry—convenient to use.

No. 354—PORTO PAD.



LIGHT-DUTY ECONOMY PAD

A quality low priced pad for the beginning drummer. Live rubber playing surface is mounted on solid angle board and base. Lightweight and easy to carry.

No. 356—LIGHT DUTY PAD.
90



LIGHT DUTY PAD AND ADJUSTABLE STAND

An economy pad and stand for the beginning drummer. The lightweight, detachable pad and folding stand are easily packed in drum case.

No. 2017—NO. 356—PAD AND STAND, complete.

No. 1329—STAND ONLY for No. 356 pad.



HEAVY DUTY PAD AND ADJUSTABLE STAND

An ideal teaching and practice arrangement using the No. 355W professional pad mounted on sturdy chrome-plated stand. Features complete height and angle adjustment.

No. 2011-1—NO. 355W—PAD AND STAND Comp.

No. 1360-1—STAND ONLY for No. 355W Pad.

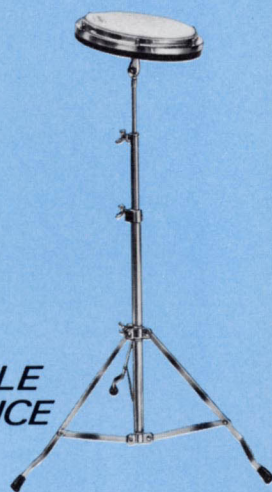

TUNABLE PRACTICE PAD AND ADJUSTABLE STAND

A quality practice pad and stand for professional and amateur drummers alike. Pad is easily detachable; chrome-plated stand folds compactly for packing.

No. 2015—No. 378—8" TUNABLE PAD AND STAND, comp.

No. 2016—No. 379—10" TUNABLE PAD AND STAND, comp.

No. 1353—STAND ONLY for No. 378 or No. 379 Pad.

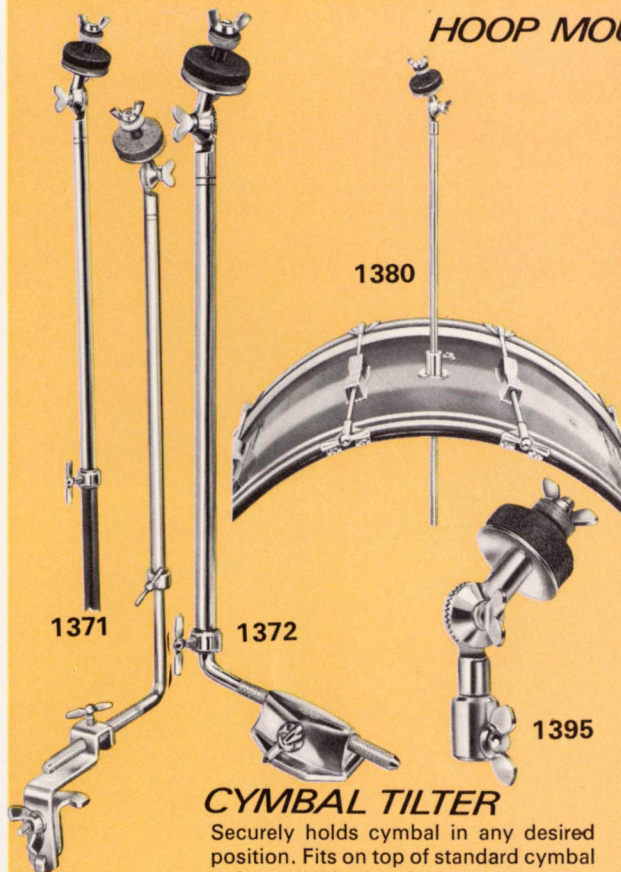

HOOP MOUNT CYMBAL HOLDER

A completely adjustable hoop mount holder with built in cymbal tilter. Holder can be mounted anywhere on your bass drum hoop. New design offers rigid cymbal mounting.

No. 1370—CYMBAL HOLDER with tilter and hoop mount bracket.

No. 1371—CYMBAL HOLDER SLEEVE, only; with tilter.

DISAPPEARING CYMBAL HOLDER

The modern shell mount cymbal holder provides fast, effortless cymbal set-up. Holder simply disappears into bass drum when not in use. Built in tilter offers cymbal angle adjustment.

No. 1380—DISAPPEARING SHELL MOUNT CYMBAL HOLDER with tilter.

SHELL MOUNT CYMBAL HOLDER

An entirely new tilting holder with complete height and angle adjustment. New die-cast bracket assures rigid cymbal mounting with modern streamlined appearance.

No. 1372—CYMBAL HOLDER with tilter and shell mount bracket.

No. 1373—CYMBAL HOLDER WITHOUT tilter and shell mount bracket (not illustrated).

CYMBAL TILTER

Securely holds cymbal in any desired position. Fits on top of standard cymbal rod; available in chrome plate only.

No. 1395—CYMBAL TILTER, only (securely fits on top of standard cymbal rod).

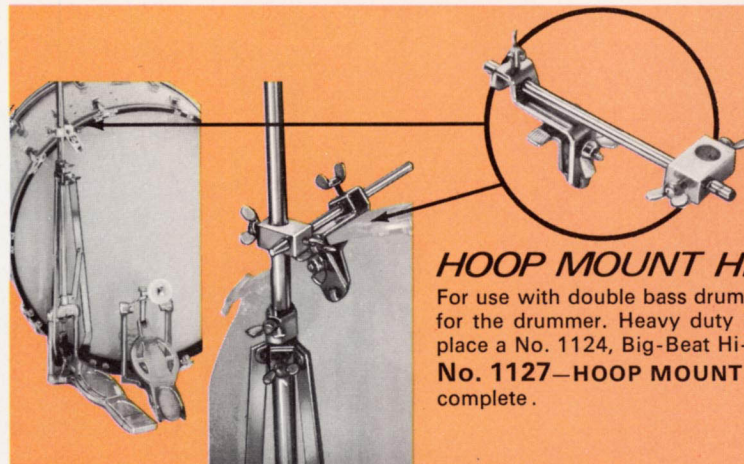

HOOP MOUNT HI HAT BRACE

For use with double bass drum outfits; assures playing ease for the drummer. Heavy duty brace supports and holds in place a No. 1124, Big-Beat Hi-Hat pedal.

No. 1127—HOOP MOUNT HI-HAT BRACE, complete.

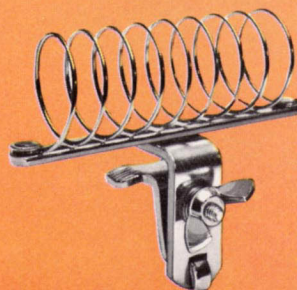

HOOP MOUNT STICK HOLDER

Sticks, brushes or mallets can be securely held in place and within easy reach of the drummer.

No. 1324—HOOP MOUNT STICK HOLDER.

LUDWIG

small concert percussion instruments and accessory items



TAMBOURS

Ludwig's tunable Tambours are made from selected shells and feature high strength plastic heads. Available in 10" and 12" diameters. Ludwig Tambours are ideal for use in band and orchestra, percussion ensemble and multiple percussion solo performance. Tambours (hand drums) can also be used for elementary classroom music instruction.

No. 4530—10" DIAMETER TAMBOUR,
1 3/4" deep shell with plastic head (coated).

No. 4535—12" DIAMETER TAMBOUR,
1 3/4" deep shell with plastic head (coated).

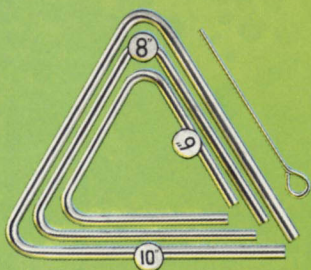

CONCERT TRIANGLES

Ludwig professional quality Triangles are made of top grade steel to provide the finest sound quality possible. Each triangle is carefully plated to prevent rusting and is permanently mounted to a Triangle Clip Holder.

No. 1333—6" CLEAR TONE TRIANGLE.

No. 1334—8" CLEAR TONE TRIANGLE.

No. 1332—10" CLEAR TONE TRIANGLE.

(Prices include beater)

TUNABLE WOOD SHELL TAMBOURINES

Ludwig provides two sizes in wood shell tambourines with tunable heads. Both the 8" and 10" are supplied with durable plastic heads, which are easily tuned to desired pitch and feel with special key. Select hardwood shells are carefully sanded and finished; special tension hooks provide even head tensioning; heads are evenly sprayed with Ruff-Kote for effective, easy thumb rolls. Ludwig 10" wood shell tambourines are available in a choice of single or double row jingles.

No. 72—8" DIAMETER WOOD SHELL TUNABLE TAMBOURINE, single row jingles (7 prs.) .

No. 99—10" DIAMETER WOOD SHELL TUNABLE TAMBOURINE, single row jingles (8 prs.) .

No. 99A—10" DIAMETER WOOD SHELL TUNABLE TAMBOURINE, double row jingles, (16 prs.) .

No. P2710—TUNING KEY.

TUNABLE ALL-METAL TAMBOURINES

Ludwig's all-metal tambourines offer a lightweight, yet extremely durable instrument that produces a bright, clear, crisp, ringing effect resulting from the play of metal on metal. The added features of heavy-duty hoops and strong plastic heads are ideal for today's modern music. Nine individually adjustable tension hooks easily tension the head with the special key to provide the desired feel and pitch. Heads are specially sprayed with Ruff-Kote to facilitate clean, easy thumb rolls. Here is the finest tambourine for those who want to add a new sound quality to their percussion section.

No. 98—10" ALL-METAL TUNABLE TAMBOURINE, single row jingles (8 prs.) .

No. 98A—10" ALL-METAL TUNABLE TAMBOURINE, double row jingles (16 prs.) .

No. P2710—TUNING KEY.

ELTON FINGER CYMBALS

Professional quality Finger Cymbals are designed to provide a clear, ringing tone that blends and accents any composition. Ideal for special effects!

No. 85—ELTON FINGER CYMBALS, pair (2-cymbals) .

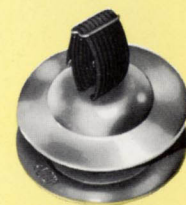

ANTIQUE FINGER CYMBALS

Provide a high pitched ring required in many contemporary compositions. Produce the proper dissonance for the most authentic "Oriental" sound. Packaged in pairs; bronze alloy antique finish.

No. 83—Antique Finger Cymbals, pair.



TRIANGLE CLIP HOLDER

This Clip Holder, equipped with strong cord, fits all music stands and is designed to enhance the resonant quality of the triangle. Triangle beater fits into holes in handle.

No. 1336—TRIANGLE CLIP HOLDER

No. 1337—TRIANGLE BEATER





91

90

92

CASTANETS

Nothing conveys the impression of a crisp, Spanish dance like these fine, professional style Castanets. Durable plastic clappers are carefully mounted on hardwood handles to provide the maximum resonance and tone quality. Ludwig Castanets can be either hand or finger controlled.

No. 90—HAND CASTANETS,
set of four clappers.

No. 91—SINGLE PAIR
CASTANETS ON HANDLE

No. 92—DOUBLE PAIR
CASTANETS ON HANDLE

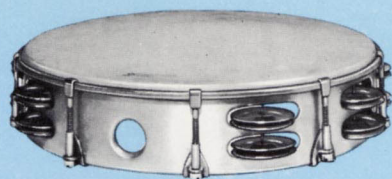

STANDARD WOOD BLOCKS

Carved from select hardwood to provide a clear, resonant tone, these Ludwig Wood Blocks are ideal for rhythmic and novelty effects. Available in two sizes.

No. 774—LARGE WOOD
BLOCK.

No. 775—SMALL WOOD
BLOCK.



TUNABLE TONE BLOCK

Ludwig's Tunable Tone Block is made of durable, black ebonite for long-lasting service and clear tone. Block is tuned by moving pins together for higher tones or apart for lower tones.

No. 777—TUNABLE TONE
BLOCK.

No. 773—SINGLE BLOCK
HOLDER.



CONCERT CASTANETS

Ludwig Concert Castanets offer professional mounting for school band and orchestra performance. Exclusive design provides instant, trouble-free response when played with fingers or soft mallets. Strong Bakelite castanets resonate against select rosewood mounting block for ideal effect.

No. 89—CONCERT
CASTANETS.



PICCOLO WOOD BLOCK

Vital for special effects and modern orchestral work, this Wood Block is very high pitched. For the most effective sound, a special Piccolo Wood Block Striker is available, quipped with standard mounting holes and felt pads.

No. 2396—PICCOLO
WOOD BLOCK.

No. 2397—PICCOLO
WOOD BLOCK
STRIKER.

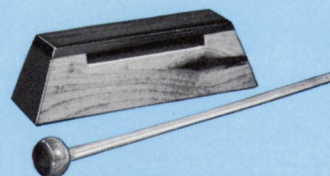

CONCERT TRAP TABLE

The Concert Trap Table is designed to hold accessory instruments, sticks and beaters for convenient, immediate use. Felt covered table top measures 18" x 24" overall. Heavy-duty, chrome-plated stand folds for easy packing; complete height adjustment offers use in standing or sitting position. A "must" for every percussion section!

No. 1378—CONCERT
TRAP TABLE,
complete.

No. 1379—TABLE
TOP ONLY.

No. 1368—
ORCHESTRA BELL
STAND ONLY.



LUDWIG

special effect percussion instruments



BIRD WHISTLE

For effective bird call imitation. For proper effect, fill half full with water; all metal.

No. 537-1—BIRD WHISTLE.



ACME SIREN

Use as wind whistle, siren whistle or cyclone. Delivers clear, high pitched tones. Made in England; all metal plated with ring for hooking on music stand.

No. 539—ACME SIREN.



PLASTIC WHISTLE

Produces an unusually high pitched sound for special whistle effects. Molded of hard and durable black plastic.

No. 542—PLASTIC WHISTLE.

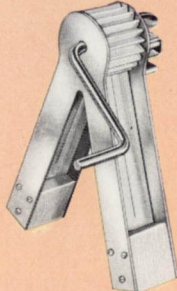

RATCHET

Made of select hardwoods with plated metal sides for more durable performance. Mounts on bass drum hoop.

No. 75—RATCHET.



SLEIGH BELLS

Ideal for concert use in many descriptive numbers as well as for the new sounds of today. Set of 25 is mounted on a strong handle.

No. 97—SLEIGH BELLS.



ORCHESTRA WHISTLE

Creates realistic tugboat and train effects. This triple tone whistle is the perfect addition to the percussion section for unusual sound effects.

No. 543—ORCHESTRAL WHISTLE, all metal.

No. 544—ORCHESTRAL WHISTLE, metal with plastic mouthpiece.

No. 545—ORCHESTRAL TRAIN WHISTLE.



SIREN HORNS

Mouth operated to produce an authentic siren sound from a small instrument. Made of stainless steel for long life and perfect tone. Adds a surprising effect for novelty and arrangements.

No. 546—SIREN HORN, 4 $\frac{3}{4}$ " long.

No. 547—SIREN HORN, 7" long.



SLAPSTICK

Top quality, hard wood activated by a strong spring to produce the desired "whip" sound. A must for the modern percussion section.

No. 74—SLAPSTICK.



ANVIL

Perfect for descriptive numbers. Comes complete with anvil, folding stand, mallet and case.

No. 4115—Anvil only.

No. 4117A—Stand only.

No. 4120A—Mallet only.

No. 4121—Case only.

No. 541—Anvil, complete outfit.



SONG WHISTLE

Ideal for glissando and special effects. All metal, chrome plated finish assures long-lasting use.

No. 536—SONG WHISTLE.



WRIST BELLS

Four resonant sleigh bells securely fastened to a wrist strap; provides accurate rhythmic manipulation.

No. 96—WRIST BELLS

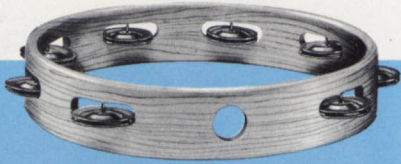

HEADLESS ROCK TAMBOURINE

Produces a strong, crisp jingle effect for the big "rock" sound. Hand-sanded, extra-strong shell is supplied as listed below. When not used on the hi-hat, this tambourine can be used in the hands for solid, effective beat.

No. 94-1—8" Headless Rock Folk Tambourine, single row, (7pr.) jingles.

No. 95-1—10" Headless Rock Folk Tambourine, single row, (8 pr.) jingles.

No. 95-2—10" Headless Rock Folk Tambourine, double row (16 pr.) jingles.

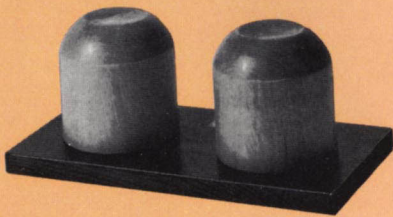

HORSES HOOFS

Reproduces the authentic galloping sound for many orchestral compositions. Consists of two, 2" diameter by 2 3/4" high, natural finish wood shells and 4" x 8" laminated walnut baseboard.

No. 2394—HORSES HOOFS .

HI-HAT SOCK JINGLE

Gives the Rock drummer added "Big Beat" coloring of the popular tambourine jingle effects. Solid rock maple shell with 8 double jingles, mounts easily on any standard hi-hat. Metal plate across tambourine keeps instrument in place; equally effective with after-beat hi-hat or sticks.

No. 88—HI-HAT SOCK JINGLE.

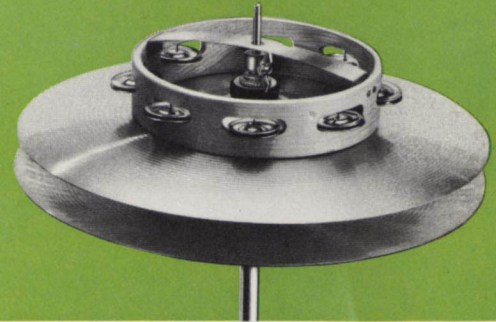

CHING RING

8 jingles bounce to produce unusual sounds and resonating rings. Use on hi-hat cymbals or by hand. Adjustable mounts; chrome finish, 7" diameter.

No. 73—CHING RING .

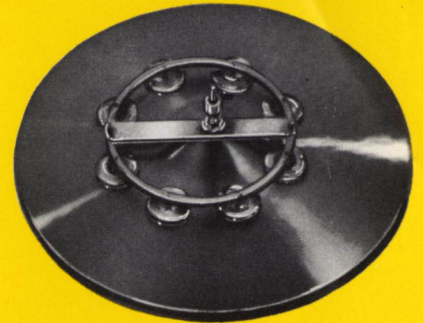

CYMBAL SIZZLER

Produces sizzling sound on your standard cymbal. Easy to mount, chrome finish. No rivets needed in cymbal.

No. 1396—CYMBAL SIZZLER .

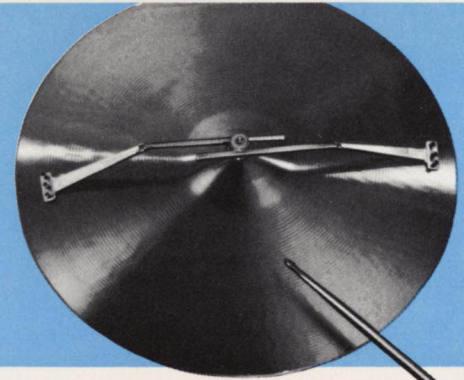

TRAP TREE

Easily attaches to bass drum cymbal mount. Comes complete as illustrated with 6" triangle, 8" cymbal, finger cymbal and trap tree.

No. 1375 TRAP TREE complete.

No. 1386 TRAP TREE only.

ROCK FOLK JINGLE STICK

Plays by striking the back of the stick against the hand offering a new "beat" for the modern group. Five double tambourine jingles are mounted on the lamo wood handle.

No. 84—ROCK FOLK JINGLE STICK .



POP GUN

Reproduces genuine "pop" sound for humorous or shock effect. 26" long tube, chrome finish; wooden ball handle plunger and cork.

No. 2395—POP GUN .



SNARE DRUM - BATTER

MEDIUM (Coated) General Purpose CT-13...13"* CT-14...14"*	HEAVY (Coated) General Purpose/Rock TO-13...13" TO-14...14"
LAMINATED (Coated) Rock RO-13...13" RO-14...14"	EXTRA HEAVY (Smooth) Single Ply - Rock XH-13...13" XH-14...14"

SNARE DRUM - SNARE

EXTRA-THIN (Opaque) S-13...13"* S-14...14"*
--

BASS DRUM HEADS

HEAVY (Smooth) General Purpose BD-18...18"* BD-22...22"* BD-20...20"* BD-24...24"* BD-26...26"*
LAMINATED (Smooth) Rock BC-18...18" BC-22...22" BC-20...20" BC-24...24" BC-26...26"
EXTRA HEAVY (Smooth) Rock XH-20...20" XH-24...24" XH-22...22" XH-26...26"

TOM TOM HEADS

MEDIUM (Coated) General Purpose CT-12...12"* CT-13...13"* CT-14...14"* CT-15...15"* CT-16...16"* CT-18...18"* CT-20...20"*	HEAVY (Coated) General Purpose/Rock TO-12...12" TO-13...13" TO-14...14" TO-15...15" TO-16...16" TO-18...18" TO-20...20"
LAMINATED (Coated) Rock RO-12...12" RO-13...13" RO-14...14" RO-15...15" RO-16...16" RO-18...18" RO-20...20"	EXTRA-HEAVY (Smooth) Single Ply - Rock XH-12...12" XH-13...13" XH-14...14" XH-15...15" XH-16...16" XH-18...18" XH-20...20"

MELODIC TOM TOM HEADS

For Octa-Plus and Quadra-Plus

MEDIUM (Smooth) TI- 6... 6"* TI- 8... 8"* TI-10...10"* TI-12...12"* TI-13...13"* TI-14...14"* TI-15...15"* TI-16...16"*	Heavy (Coated) TO- 6... 6" TO- 8... 8" TO-10...10" TO-12...12" TO-13...13" TO-14...14" TO-15...15" TO-16...16"
--	---

NOTE: Special treatment for tonal center applied to all "TI" heads 13" and larger. For complete information refer to page 98.

WEATHER MASTER CLEAR HEADS

SNARE DRUM AND TOM TOM HEADS

EXTRA THIN (Snare) CS-13...13" CS-14...14" CS-15...15" CS-16...16"	MEDIUM CM- 6... 6" CM- 8... 8" CM-10...10" CM-12...12" CM-13...13" CM-14...14" CM-15...15" CM-16...16" CM-17...17" CM-18...18"	HEAVY CH- 6... 6" CH- 8... 8" CH-10...10" CH-12...12" CH-13...13" CH-14...14" CH-15...15" CH-16...16" CH-17...17" CH-18...18"
---	---	--

BASS DRUM HEADS

HEAVY CB-20...20" CB-22...22" CB-24...24" CB-26...26" CB-28...28" CB-30...30" CB-32...32" CB-34...34" CB-36...36" CB-40...40"
--

WEATHER MASTER HEADS FOR MARCHING PERCUSSION

BATTER HEADS FOR SNARE AND TENOR DRUMS

HEAVY (Smooth)	LAMINATED (Smooth)	EXTRA-HEAVY (Smooth)	
PA-13...13"	DC-13...13"	XH-13...13"	NOTE: Standard equipment head weights are not indicated with (*), as they vary between drum models.
PA-14...14"	DC-14...14"	XH-14...14"	
PA-15...15"	DC-15...15"	XH-15...15"	
PA-16...16"	DC-16...16"	XH-16...16"	
PA-17...17"	DC-17...17"	XH-17...17"	

SNARE HEADS

EXTRA-THIN (Opaque)
S-13...13"*
S-14...14"*
S-15...15"*
S-16...16"*

HEADS FOR MARCHING BASS DRUMS

HEAVY (Smooth)		LAMINATED (Smooth)		EXTRA-HEAVY (Smooth)		NOTE: Standard equipment head weights are not indicated with (*), as they vary between drum models.
BD-20...20"	BD-30...30"	BC-20...20"	BC-26...26"	XH-20...20"	XH-26...26"	
BD-22...22"	BD-32...32"	BC-22...22"	BC-28...28"	XH-22...22"	XH-28...28"	
BD-24...24"	BD-34...34"	BC-24...24"	BC-30...30"	XH-24...24"	XH-30...30"	
BD-26...26"	BD-36...36"		BC-32...32"			
BD-28...28"	BD-40...40"					

HEADS FOR MARCHING TIMP TOM UNITS

MEDIUM (Smooth)		HEAVY (Smooth)
TI-12...12"*	TI-18...18"*	BD-12...12"
TI-13...13"*	TI-20...20"*	PA-13...13"
TI-14...14"*	TI-22...22"*	PA-14...14"
TI-15...15"*	TI-24...24"*	PA-15...15"
TI-16...16"*	TI-26...26"*	PA-16...16"
TI-17...17"*	TI-28...28"*	PA-17...17"

NOTE: Special treatment for tonal center applied to all "TI" heads 13" and larger. For complete information refer to page 98.

MARCHING TIMPANI HEADS

MEDIUM (Smooth)
T-20...20"*
T-23...23"*
T-26...26"*
T-29...29"*

WEATHER MASTER HEADS FOR CONCERT PERCUSSION

BATTER HEADS FOR CONCERT SNARE DRUMS

THIN (Coated)	MEDIUM (Coated)	HEAVY (Coated)
OR-13...13"	CT-13...13"*	TO-13...13"
OR-14...14"	CT-14...14"*	TO-14...14"
OR-15...15"	CT-15...15"*	TO-15...15"

SNARE HEADS

EXTRA-THIN (Opaque)
S-13...13"*
S-14...14"*
S-15...15"*

HEADS FOR CONCERT TOM TOMS

MEDIUM (Smooth)		HEAVY (Coated)
TI-6...6"*	TI-14...14"*	TO-6...6"
TI-8...8"*	TI-15...15"*	TO-8...8"
TI-10...10"*	TI-16...16"*	TO-10...10"
TI-12...12"*		TO-12...12"
TI-13...13"*		TO-13...13"

NOTE: Special treatment for tonal center applied to all "TI" heads 13" and larger. For complete information refer to page 98.

CONCERT BASS DRUM HEADS

HEAVY (Smooth)
BD-18...18"*
BD-20...20"*
BD-22...22"*
BD-24...24"*
BD-26...26"*

BD-28...28"*
BD-30...30"*
BD-32...32"*
BD-34...34"*
BD-36...36"*
BD-40...40"*

TIMPANI HEADS (MEDIUM)

REGULAR COLLAR (White)	REGULAR COLLAR (Clear)	EXTENDED COLLAR (White)	EXTENDED COLLAR (Clear)
T-20...20"*	T-28...28"*	TC-20...20"	TC-28...28"
T-23...23"*	T-29...29"*	TC-23...23"	TC-29...29"
T-25...25"*	T-30...30"*	TC-25...25"	TC-30...30"
T-26...26"*	T-32...32"*	TC-26...26"	TC-32...32"

Extended collar heads DO NOT fit regular bowl counter hoops and are only for the new double ring suspension "Dresden" and "Professional Symphonic" models

WEATHER MASTER HEADS FOR SPECIAL USE

TIMBALE

CT-13...13"*
CT-14...14"*

BONGO

BO-6...6"*
BO-8...8"*

CONGA

CO-12...12"*

TAMBOURINE/PRACTICE PAD

TA-8...8"*
TA-10...10"*

LUDWIG® weather master® "thermolene"® plastic heads

LUDWIG "TI" SERIES THE PROVEN HEAD FOR ABSOLUTE DEFINITION

Ludwig is proud to have been the leader in developing a drum head specifically designed to offer true pitch tuning for single headed melodic drums. The new emphasis on melodic percussion in marching bands and drum corps, created the need for a drum head which could be tuned to a truer pitch rather than a graduated indefinite pitch.

Ludwig's application of a special treatment to the under-side of the head gives the head more tonal center, eliminating the unwanted partial in the over-tone sequence. This process also gives the head absolute definition for more articulate separation. The "TI" series head is a multiple-faceted head, giving both tonal resonance and percussive dryness depending upon where the head is struck. Research indicated that the treatment was only necessary on heads 13" and larger in diameter. These heads have been accepted and praised by leading educators and professionals as the answer to the problem of pitch tuning melodic drums for today's advances in orchestral percussion music. In addition, the head has received wide acclaim with outfit drummers

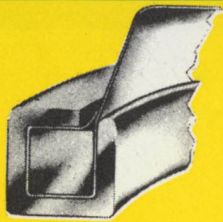
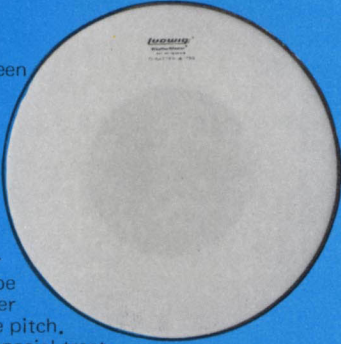

Patented mechanically sealed mounting is guaranteed not to pull out. This assures many years of trouble-free use.

Pat. No. RE 26,415



New, improved collar is designed for easier mounting, faster "seating", more permanent tensioning. Rounder and deeper for more responsive and resonant sound.



RUFF-KOTE HEAD SPRAY

Roughens plastic batter heads for perfect wire brush response; ideal for tambourine thumb rolls. Plastic heads should be cleaned often with soap and water, scrubbing vigorously with a stiff brush; dry carefully. Apply thin coating of "Ruff-Kote" spray, when required. Allow at least 12 hours for drying.

No. 5—LUDWIG
"RUFF-KOTE"
AEROSOL CAN.

As a result of extensive research and years of testing, LUDWIG now offers you a complete new line of polyester heads especially crafted to meet the playing needs of today's drummers and timpanists.

Each head has been subjected to a series of tests designed to determine tonal output, response, resonance and clarity of definition, to provide the acoustical properties required by the performing group.

Ludwig's new line of plastic heads are made on special machines designed and built by Ludwig engineers to assure controlled, consistent sound quality for the best in musical performance.

LUDWIG

offers the newly crafted "thermolene"® plastic heads in a series of six different weights:

EXTRA THIN (.003 mil.)

a very light weight translucent, ultra-sensitive head, designed for use as a snare head, only.

THIN (.005 mil.)

a light weight, milk white, very sensitive head, designed for use as an orchestral batter head, only. The playing surface is coated with Ludwig's new formula "Ruff-Kote" finish. Properly tensioned, the head will produce a very dry, crisp sound. Recommended for very fine, delicate playing.

MEDIUM (.0075 mil.)

a medium multi-purpose weight, milk white, sensitive head, designed for use as a batter head only. This medium weight batter head is standard on outfit snare drums and tom toms, concert toms, timp-toms, timpani, bongos, timbales, tambourines and practice pads. The tonal response of these heads allows for a wide range of tunings. Bongo heads have permanently tormed deep collars.

HEAVY (.010 mil.)

a heavy weight, multi-purpose, single ply, milk white, batter head. Ideal for use on all outfit Snare Drums and Tom Toms where greater volume and durability is required. Note: This head weight is used on all Bass Drums and Conga Drums.

LAMINATED (.0125 mil.)

a 2 ply multi-purpose weight, milk white head, designed for use as a batter head, only. Ideal for rock and drum corps where heavy impact is necessary for performance. Tonal response is excellent, duration-short, resonance-clear and high pitched, projection-powerful.

EXTRA HEAVY (.014 mil.)

an extra heavy weight, milk white head, designed for use as a batter head only. This single-ply head offers maximum strength, rapid recovery, and over-all durability. Tested and used by leading drum and bugle corps, and rock drummers, the heavy weight withstands tremendous impact without sacrificing tonal response or projection.

NOTE:

The information above is intended as general descriptive information regarding the various head weights available. When ordering drum heads please specify catalog number and size as listed on pages 96 & 97.

*fibre cases
and covers for*

**LUDWIG[®]
MUSSER**

instruments



**MARIMBAS
VIBES
XYLOPHONES
CHIMES**

Your expensive mallet instruments need and deserve the protection offered by a line of top grade vulcanized fibre carrying cases. Each set of cases is carefully designed to provide maximum protection and ease of portability. Special construction features include: Heavy gauge vulcanized fibre used throughout. Metal reinforcement on all corners, special "shock" mountings and blocks for each individual part, special cloth roll-up divider for all removable wood and metal keyboards.

- No. M-135**—Set of 2 cases for M61 (M60) Triette Marimba.
- No. M-136**—Set of 3 cases for M31 Windsor II Marimba.
- No. M-141**—Set of 5 cases for M75 Century Vibe.
- No. M-142**—Set of 3 cases for M48 or M45 Portable Vibe.
- No. M-143**—Set of 4 cases for M150 Century Marimba.
- No. M-144**—Set of 3 cases for M30 Brentwood Marimba.
- No. M-145**—Single case for M21 (M20) Prep Marimba.
- No. M-146**—Set of 2 cases for M51 (M50) Portable Xylophone.
- No. M-147**—Single case for M42 (M43) Elite Xylophone.
- No. M-148**—Set of 5 cases for M250 Concert Grand Marimba.
- No. M-149**—Set of 3 cases for M55 Pro Vibe.
- No. M-158**—Set of 3 cases for M635 Chimes.

**NEW VINYL FLEECE
LINED COVERS FOR
LUDWIG/MUSSER
MALLET INSTRUMENTS**

If your mallet percussion instruments are left standing in a studio, band or orchestra room, club or at home, they need the protection of Ludwig's new Vinyl Fleece Lined covers. The handsome black vinyl cover will protect the keyboard from the elements and unauthorized personnel. Each cover is perfectly tailored to fit each keyboard with a 6" drop on all sides.

- No. M-160**—Cover for M21 (M20) Prep Marimba.
- No. M-161**—Cover for M30 Brentwood Marimba.
- No. M-162**—Cover for M42 (M43) Elite Xylophone.
- No. M-163**—Cover for M48 or M45 Portable Vibe.
- No. M-164**—Cover for M51 (M50) Portable Xylophone.
- No. M-165**—Cover for M55 Pro Vibe.
- No. M-166**—Cover for M61 (M60) Triette Marimba.
- No. M-167**—Cover for M75 Century Vibe.
- No. M-168**—Cover for M150 Century Marimba.
- No. M-169**—Cover for M250 Concert Grand Marimba.
- No. M-170**—Cover for M31 Windsor II Marimba.
- No. M637**—Cover for M630 and M631 Chimes.



LUDWIG FIBRE CASES



Metal stripping on all edges.

100% heavy vulcanized fibre throughout.

NEW CLASSIC PAK'N ROLL TRAP CASE

Complete with wider insert tray, mounted oversized heavy duty castor wheels, leather strap fasteners and steel handles at both ends, the NEW CLASSIC PAK'N ROLL TRAP CASE provides the percussionist with the ultimate in a carrying and porting case. This new oversized case allows for the storage of a 5" x 14" or 6½" x 14" snare, round stool seat and 10" tambourine in one compartment, accessory stands in another compartment, and cymbals up to 22" in diameter in another compartment. The wider tray accommodates additional accessory items, sticks, brushes, mallets and small percussion instrument items.

No. 8020W—NEW CLASSIC PAK'N ROLL TRAP CASE.

New heavy duty steel handles on both sides of case.

5 ply wood bottom for rigid construction.

Steel corner guards.

Large oversized castor wheels for long life.

CASES FOR OCTAPLUS DRUM OUTFIT

1- No. 8362 for 5½" x 6"
5½" x 8"
6½" x 10"
8" x 12"

1- No. 8565 for 10" x 14"
14" x 16"

1- No. 8866 for 16" x 18"

1- No. 6671 for 9" x 13"
12" x 15"

2- No. 6991 for 14" x 22"

1- No. 8020W for 5" x 14"
and accessories



No. 8023— Replacement straps for 8020W, 8021, 8021W Trap Case, per pr.

CASES FOR QUADRAPLUS DRUM OUTFIT

1- No. 6671 for 9" x 13"
12" x 15"

1- No. 8866 for 16" x 18"

1- No. 6991 for 14" x 22"

1- No. 8565 for 10" x 14"
14" x 16"

1- No. 8020W for 5" x 14"
and accessories

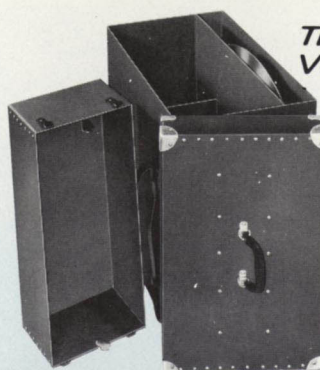

THE HOLD-ALL VULCANIZED TRAP CASE

Ludwig first designed this style of case to accommodate those large diameter cymbals. Made of sturdy vulcanized fibre with heavy-duty steel corner guards and sturdy carrying handle. Holds snare drum, cymbals, and all accessories neatly and compactly.

No. 8021—HOLD-ALL TRAP CASE.



**NEW
BASS DRUM FIBRE CASES**

Ludwig's NEW BASS DRUM FIBRE CASES were designed to accommodate the following bass drums with the new curved spurs. Cases are form-fitted, rigid and mounted with heavy duty handles.

- No. 6892—12" x 18".
- No. 6893—14" x 18".
- No. 6891—12" x 20".
- No. 6890—14" x 20".
- No. 6992—12" x 22".
- No. 6991—14" x 22".
- No. 8676—12" x 24".
- No. 8680—14" x 24".
- No. 8681—14" x 26".

**REGULAR TELESCOPIC
BASS DRUM FIBRE CASES**

- No. 8675— 6" x 26".
- No. 8679— 8" x 26".
- No. 8687—10" x 26".
- No. 8677— 6" x 28".
- No. 8688—10" x 28".
- No. 8690—12" x 28".
- No. 8682—14" x 28".

- No. 8689—10" x 30".
- No. 8683—14" x 30".
- No. 8684—16" x 32".
- No. 8685—16" x 34".
- No. 8686—16" x 36".
- No. 8678—18" x 40".

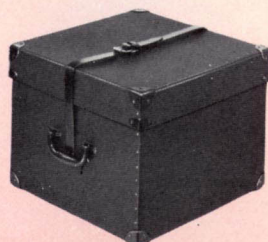

**SQUARE VULCANIZED
FIBRE CASE
SUPER-SENSITIVE DRUMS**

Designed to accommodate the Super-Sensitive snare mechanisms.

- No. 7154—Case for 14" diameter Super-Sensitive drums.
- No. 7155—Case for 14" and 15" diameter Super-Sensitive parade drums.
- No. 7159—Case for 16" diameter Super Sensitive parade drums.



**ROUND TELESCOPIC
FLAT BOTTOM
VULCANIZED FIBRE CASES**

Designed to hold the following drum sizes.

SNARE DRUM FIBRE CASES

- No. 7149—3" x 13".
- No. 7150—4" / 5" / 6½" x 14".
- No. 7151—6½" x 15".

PARADE DRUM FIBRE CASES

- No. 6470—10" x 14".
- No. 6571—10" x 15".
- No. 6671—12" x 15".
- No. 6772—12" x 16".
- No. 6873—12" x 17".
- No. 6993—16" x 22".

TOM TOM FIBRE CASES

- No. 8361—8" x 12".
- No. 8362—9" x 13".
- No. 8364—Combination case for tom toms, 8" x 12" and 9" x 13".
- No. 8464—14" x 14".
- No. 8565—16" x 16".
- No. 8866—16" x 18".
- No. 8588—18" x 20".
- No. 8566—Combination case for tom toms, 8" x 12" and 14" x 14".
- No. 8567—Combination case for tom toms, 9" x 13" and 16" x 16".

SPECIAL FIBRE CASES

- No. 8122—Bongo case.
- No. 8888—Conga or seat case.
- No. 840—Fibre case for 20" Marching Timpano.
- No. 841—Fibre case for 23" Marching Timpano.
- No. 843—Fibre case for 26" Marching Timpano.
- No. 845—Fibre case for 29" Marching Timpano.

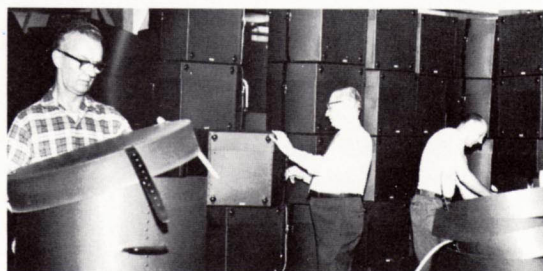

LUDWIG is the only drum company operating its own case department—your guarantee of a perfect fit.

LUDWIG cases and covers



CONTOURA DRUM KIT CASES

Ludwig's line of CONTOURA drum kit cases have met with great acceptance from student, educator and dealer alike. Designed to provide maximum protection for drums and accessories, CONTOURA cases are molded of durable, high impact, plastic and trimmed in bright satin extruded aluminum. Three heavy-duty latches and double hinges securely hold the case closed. Drum fits comfortably into top of case; separate bottom compartment holds all accessories. Lightweight CONTOURA cases are available in three interior finishes: unlined, blue felt-lined or red plush-lined.

No. 8030—UNLINED CONTOURA CASE.

No. 8031—FELT-LINED CONTOURA CASE.

No. 8032—PLUSH-LINED CONTOURA CASE.



MALLET AND MUSIC CASE

Ludwig introduces a handsome new case designed especially for carrying valuable sheet music, beaters and mallets. The seamless, molded, textured acrylic case provides maximum protection as well as long-lasting beauty. Smart looking hardware is plated for exceptional service. The case measures 17½" x 12" overall and has a handy pocket in the cover for storing sheet music.

No. 7156-1—MALLET AND MUSIC CASE.



DURA-HYDE TIMPANI STICK BAG

Made of Ludwig's handsome black DURA-HYDE, this durable, new Timpani Stick Bag is designed for long-lasting protection to valuable timpani sticks when not in use. Bag hangs conveniently on the timpani during performance, in easy reach of the player. DURA-HYDE bag accommodates 4 pairs of timpani sticks.

No. 340—TIMPANI STICK BAG.



PARADE KIT CASE

A square fibre case designed for the economy 10" x 14" parade drum kit. Top protection—easy to carry.

No. 7153—10" x 14" PARADE DRUM CASE

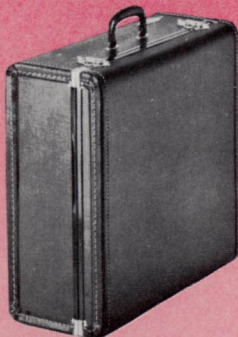

CONCERT KIT CASE

A quality low priced case designed for the 5" x 14" concert drum. Holds drum, stand, sticks, books and small accessories.

No. 7152—CONCERT KIT CASE.



THE EXCLUSIVE LUDWIG SEAT-CASE

The Ludwig SEAT-CASE performs a twofold function. It is both an attractive seat which is available in finishes to match your outfit as well as a case to hold all your stands and accessories. Seat is padded and covered with beautiful black leatherette. Supplied with zipper cover at no additional cost.

No. 1027—DRUMMERS SEAT-CASE in choice of pearl finishes.



**DURA-HYDE
DRUM COVERS**

Handsome DURA-HYDE covers, made of heavy long-wearing, weather resistant, fabric-backed vinyl, offer the finest protection at moderate cost. These popular covers are supplied in striking jet black leather tone and are easy to clean to retain their "new look" for years. Exclusive features include heavy-duty zippers, double strength handles and bumper bindings. Available individually or in sets.

SNARE DRUM COVERS

- No. 170—3" x 13"
- No. 171—4" x 14"
- No. 172—5" x 14"
- No. 173—6½" x 14"
- No. 174—6½" x 15"

TOM TOM COVERS

- No. 175— 8" x 12"
- No. 176— 9" x 13"
- No. 177—14" x 14"
- No. 178—16" x 16"
- No. 179—16" x 18"
- No. 180—18" x 20"

PARADE DRUM COVERS

- No. 270—10" x 14"
- No. 271—10" x 15"
- No. 272—12" x 15"
- No. 273—12" x 16"
- No. 274—12" x 17"

**SCOTCH BASS
DRUM COVERS**

- No. 275—16" x 26"
- No. 276—10" x 26"
- No. 277— 8" x 28"
- No. 278—10" x 28"
- No. 279—10" x 30"

**DANCE BASS DRUM
COVERS**

- No. 181—16" x 24"
- No. 182—12" x 18"
- No. 183—14" x 18"
- No. 184—12" x 20"
- No. 185—14" x 20"
- No. 186—12" x 22"
- No. 187—14" x 22"
- No. 188—14" x 24"
- No. 189—14" x 26"

**CONCERT BASS
DRUM COVERS**

- No. 280—14" x 28"
- No. 281—14" x 30"
- No. 282—16" x 32"
- No. 283—16" x 34"
- No. 284—16" x 36"
- No. 285—18" x 40"

DRUM COVER SETS

- No. 160-1— 5" x 14"
8" x 12"
14" x 14"
14" x 20"

- No. 161-1— 5" x 14"
9" x 13"
16" x 16"
14" x 22"

- No. 162-1— 5" x 14"
8" x 12"
9" x 13"
16" x 16"
14" x 22"

- No. 286 —Throne Seat
Cover

- No. 172-1— 5" x 14"
Super-Sens.
Cover

- No. 173-1—6½" x 14"
Super-Sens.
Cover



**BLUE SHARKSKIN
ZIPPER COVERS**

New Ludwig Blue Sharkskin covers are made from the finest materials available. They are top quality water repellent, fleece-lined covers offering years of protection and service. Easy zipper action provides fast packing of drums.

BASS DRUM COVERS

- No. 151S—12" x 18"
- No. 152S—14" x 18"
- No. 154S—12" x 20"
- No. 155S—14" x 20"
- No. 156S—12" x 22"
- No. 157S—14" x 22"
- No. 54S —14" x 24"
- No. 56S —14" x 26"
- No. 49S —14" x 28"
- No. 50S —14" x 30"
- No. 52S —16" x 32"
- No. 58S —16" x 34"
- No. 60S —16" x 36"
- No. 59S —18" x 40"
- No. 48S —24" x 16"

SNARE DRUM COVERS

- No. 33S —3" x 13"
- No. 34S —4" x 14"
- No. 30S —5½" x 14"
- No. 30AS—5" x 14"
- No. 31S —6½" x 14"
- No. 32S —6½" x 15"
- No. 32AS—8" x 15"

TOM TOM COVERS

- No. 43S— 8" x 12"
- No. 35S— 9" x 13"
- No. 51S—14" x 14"
- No. 29S—16" x 16"
- No. 64S—16" x 18"
- No. 44S—18" x 20"

SCOTCH BASS DRUM COVERS

- No. 53S— 8" x 26"
- No. 47S—10" x 26"
- No. 61S— 8" x 28"
- No. 62S—10" x 28"
- No. 66S—10" x 30"

PARADE DRUM COVERS

- No. 38S—10" x 14"
- No. 39S—10" x 15"
- No. 40S—12" x 15"
- No. 41S—12" x 16"
- No. 42S—12" x 17"
- No. 55S—12" x 18"

LUDWIG

EDUCATIONAL SERVICES

For over fifty years, Ludwig Industries has played an active and vital role in the area of music education through its printed materials, the Ludwig Drummer, clinics by internationally known percussion artists and educators, and the cataloging of selected percussion publications. The Educational Department is constantly expanding Ludwig's program of services for schools, colleges, organizations, dealers and the individual, covering every aspect of modern concepts in "Total Percussion" and "Specialization." The services are recognized as being the most comprehensive in the music industry.



LUDWIG

CLINIC PROGRAM-

Working with a talent roster of internationally known Ludwig artists and educators, the Educational Department assists coordinators and managers in obtaining the services of an individual to appear in clinic or concert at a local, national, or international music event. Through this talent roster, every aspect and style of percussion performance is covered: product maintenance, teaching pedagogy, rudimental, marching, concert, ensemble, jazz, rock, Latin-American and mallet-keyboard.

The following is a partial listing of percussion artists and educators available through Ludwig's Educational Department:

FRANK ARSENAULT	CARMINE APPICE	TOM BROWN	ART CAPPIO
BOBBY CHRISTIAN	GARY BURTON	RON FALTER	J. C. COMBS
ANDREW CYRILLE	SHELLY ELIAS	ROY HAYNES	TOM DAVIS
MARVIN DAHLGREN	GEORGE GABER	JIM LATIMER	DON KOSS
FREDERICK FENNELL	DERRYL GOES	AL LEMERT	AL PAYSON
DAVID FRIEDMAN	HAROLD JONES	JIM SEWREY	DICK TALBOT
L. VANLANDINGHAM	RON KEEZER	RONNIE SIMON	ED THIGPEN
MITCH MARKOVICH	JOSHUA MISSAL	DUANE THAMM	BOB TILLES
GARY OLMSTEAD	JOE MORELLO	JIM MOORE	RON TUTT
GORDON PETERS	DICK GERLACH	AL IPRI	

Complete details on a Ludwig clinician and information pertaining to engaging a clinician's services are only available to educational organizations, institutions and authorized Ludwig dealers. Send for complete details and fees; simply address your request to Clinic Program, Educational Department, Ludwig Industries.

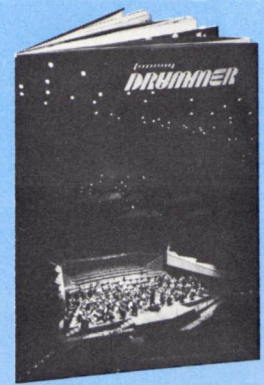

THE LUDWIG DRUMMER-

The Ludwig Drummer is a magazine devoted solely to the advancement of the art of percussion, written by and for percussionists. Published periodically, it is distributed world-wide. Copies may be obtained, without charge, from your local Ludwig dealer or by writing directly to Ludwig Industries, Educational Department.

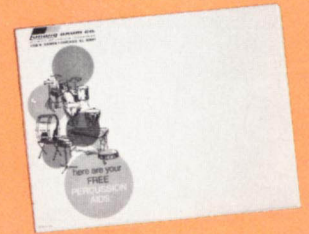

PERCUSSION AID PACK-

Information covering most Ludwig products and phases of percussion performance are available in quantities to schools, colleges, dealers and the clinics. Individual copies are also available. In addition, a comprehensive portfolio has been prepared . . . the General Percussion Aid Pack. All of the above are available from your local Ludwig dealer or by writing directly to Ludwig Industries, Educational Department, and is free upon request. (please specify).

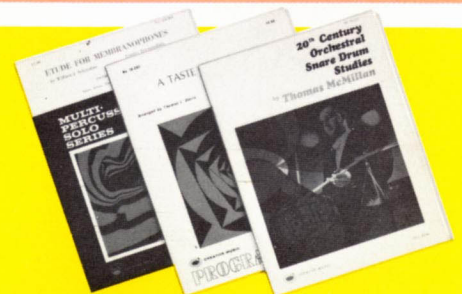

PUBLICATION DEPARTMENT

Available through Ludwig Industries are selections of publications dealing with percussion. . . snare drum studies, rudimental and multiple percussion solos, mallet-keyboard studies and solos, timpani studies, drum outfit and Latin percussion studies, marching percussion studies, and stage band/studio ensemble - concert band - woodwinding and brass choir - percussion ensemble compositions.

HOW TO ORDER

Ludwig products are sold by authorized music dealers everywhere and are only available through these dealers.

WHEN ORDERING, PLEASE GIVE CATALOG NUMBER AND COMPLETE INFORMATION ON SIZE, COLOR, FINISH AND ANY SPECIAL INSTRUCTIONS. PLEASE GIVE SHIPPING INSTRUCTIONS PLAINLY. BE SURE TO SPECIFY ZIP CODE ON ALL ORDERS.

Holders will be mounted unless otherwise specified. All Drums are supplied with Ludwig Weather Master plastic heads.

All special colors and models accepted only on a non-returnable and non-cancellable basis.

Prices and specifications subject to change without notice.

MINIMUM ORDER REQUIREMENT

A minimum order of \$10.00 list is required when ordering any combination of Ludwig products.

DELIVERY:

F.O.B. Factory, Chicago

INDEX

	Page		Page		Page
A Accessory Instrument	92, 93, 94, 95	G Glockenspiel , Bell Lyra	72, 73	Snare Drum Quartet	28
Acrolite Beaters	88, 89	Gongs, Tam-Tams, Stands	82	Snare Drums	22, 24, 25, 26, 28
Acrolite Drum	25	Gong/Tam-Tam Covers	83	Snare Drum Stands	18, 20, 21
Acrolite Drum Kits	30, 31, 32, 33	Gong/Tam-Tam Mallets	83	Snares	27
Afuche (Cabasa)	65	Guiro	65	Song Whistle	94
Agogo Bells	64	H Hand Drums (Tambours)	92	Special Effect Instruments	94, 95
Airlift Throne	19	Heads, Plastic	96, 97, 98	Spur Stop	39
All-metal Parade Drums	44, 45	Hi-Hat Sock Pedals	20, 21	Spurs	39
B Bass Drums	37, 43, 44, 45, 46	Hi-Hat Stands	20, 21	Sticks (Bass Drum)	85, 88, 89
	47, 48, 49, 50, 81	Hi-Stepper	51	Sticks (Snare Drum)	85, 86, 87
Bass Drum Anchor	39	J Junior Percussionist Kits	29	Sticks (Tenor Drums)	85, 89
Bass Drum Carriage	81	K Kits	29, 30, 31, 32, 33, 34	Sticks (Timbale)	63
Bass Drum Covers	81, 103	Ka-Me-So	65	Sticks (Timp-Tom Trio)	85, 89
Bass Drum Cymbal Holder	80	L Latin-American Instruments	62, 63, 64, 65	Sticks (Timpani)	42, 85, 88
Bass Drum Impact Pad	39	Leg Rests	50	Stools	19, 20, 21
Bass Drum Muffler	39	M Mallets (Gongs/Tam-Tams)	83	Street Drums	40, 41, 42, 43, 44, 45
Bass Drum Stand	80	Maracas	65		46, 47, 48, 49, 50
Bass Drum Tilter Stand	81	Marching Accessories	51	Suspended Bass Drum Stand	81
Baton (Drum Major's Signal)	51	Marching Holders	40, 51	Swing Flags	51
Beaters and Mallets	85, 88, 89	Marching Congas, Bongos	40, 63	T Tam-Tams	82
Bells, chromatic	72, 73	Marching Timbales, Holders	51	Tambourines	92, 93, 95
Bell Lyras and Accessories	72, 73	Marching Timpani	42	Tambours	92
Bird Whistle	94	Marimbas	68, 69	Temple Blocks and Stands	79
Bongo Drums	63	McCormick Mallets	85	Tenor Drum Holder	51
Bongo Drums (Marching)	63	Multi-Angle Carrying Hook	51	Tenor Drums	43, 44, 45, 46, 47, 48
Bongo Hoop Mount Holder	63	Multi-Mount Carrying Holder	40	Thin-Line Scotch Bass Drum	49
Brushes	84	Music Holder, Bell Lyra	73	Thrones	19, 20, 21, 102
C Cases	23, 100, 101, 102, 103	Music Rack	78	Timbales	63
Cases (Musser)	99	Musser Cases and Covers	99	Timbale Cow Bell	64
Castanets	93	Musser Mallets and Accessories	76, 77, 78	Timbale-Cow Bell Holder	63
Chimes, Covers	74, 75, 99	N Name Plates	39	Timp-Tom Trios and Duos, Cases	40, 41
Chime mallets	77	Nylon Tip Sticks	85, 86, 87	Timpani	42, 54, 55, 56, 57, 58, 59, 60
Claves	65	O Oak Sticks	85	Timpani Accessories	61
Concert Bass Drums	80	Orchestra Bells	72, 73, 75	Timpani, Machine	60
Concert Bass Drum Tilter Stand	81	Orchestra Bell Stand	78	Timpani, Marching	42
Concert Tom Toms and Stands	79	Orchestral Whistle	94	Timpani, Trunks and Covers	61
Conga Drums	62	P Parade Drums	40, 41, 42, 43, 44, 45	Timpani Tuning Gauges	61
Covers	81, 83, 99, 101, 102, 103		46, 47, 48, 49, 50	Tom Toms	35, 36
Covers (Musser)	99	Pedals	17, 18	Tom Tom Floor Stand	38, 39
Cow Bells	64	Piccolo Snare Drum	25	Tom Tom Shell Mount Holders	38
Cymbals	82	Piccolo Wood Block	93	Tuning Forks and Bars	78
Cymbal Accessories	83, 95	Pick-Up, Ampli, for Vibes	71	Trap Table	93
Cymbal Holders, Grips, Handles	83, 91	Plastic Heads	96, 97, 98	Trap Tree	95
Cymbal Polish	83	Pop Gun	95	Triangles	92
Cymbal Pouch	83	Porto-Seat	20	V Verti-Holder	51
Cymbal Stands	20, 21	Practice Pads, Holders, Stands	90, 91	Vibes	70, 71
D Dinner Gongs	82	R Ratchet	94	Vibra-Slaps	65
Drum Kits	30, 31, 32, 33	Recorder	34	W Whistles (Bird, Orchestral, Siren, Song)	94
Drum Major's Signal Baton	51	Ruff-Kote	98	Whistle (Drum Major)	51
Drum Outfits	4, 5, 6, 7, 8, 9	S Scotch Bass Drums	43, 44, 45, 46, 47, 48	Wire Brushes	84
	10, 11, 12, 13, 14, 15, 16	Scotch Bass Drum, Thin-Line	49	Wood Blocks	93
Drum Seats	19, 20, 21	Siren Horn	94	X Xylophones	66, 67
Drum Stands	18, 20, 21	Siren Whistle	94		
Drum Stand Extension Tube	21	Slapstick	94		
Dura-Hyde Covers	23, 103	Sleigh Bells	94		
E Extension Tube (Drum Stand)	21	Slings	51		
F Field Drums	40, 41, 42, 43, 44, 45				
	46, 47, 48, 49, 50				
Finger Cymbals	92				
Flags (Swing)	51				



DRUM COMPANY

DIVISION OF
LUDWIG INDUSTRIES
1728 No. Damen Ave.
Chicago, Illinois 60647
(312) 276-3360

Parts and Kitching classroom instruments are contained in separate catalogs.

LUDWIG[®] DRUM CO.

DIVISION OF LUDWIG INDUSTRIES
1728 N. Damen Ave., Chicago, Ill. 60647

PEARL FINISHES

are the product of one of the world's leading chemical manufacturers. They are the finest available and will add extra life and lasting beauty to your drums. The hard surface will not scratch, peel or chip. Ludwig now offers the new Multi-Sparkle* pearl; combining any two of the 6 sparkling finishes. Multi-Sparkle* pearl is another Ludwig quality feature available at no extra cost. When ordering—specify outer color first, inner color second.



GOLD SILK No. 8026



WHITE MARINE No. 2005

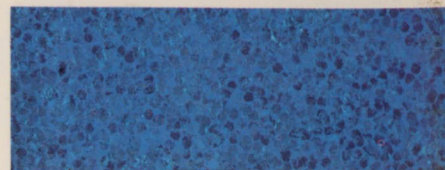

SPARKLE BLUE No. 2001

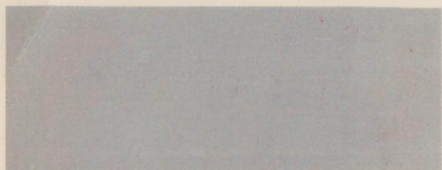

SILVER SILK No. 8027



OYSTER BLACK No. 8025

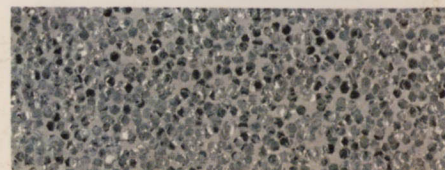

SPARKLE SILVER No. 2003



RED SILK No. 8029



SKY BLUE No. 2011

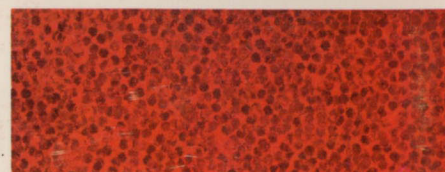

SPARKLE RED No. 2000



BLUE SILK No. 8028



OYSTER BLUE No. 8024

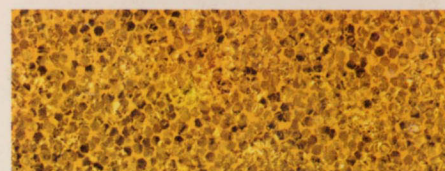

SPARKLE GOLD No. 2002



BLACK PANTHER No. 8019



BLACK DIAMOND No. 2006

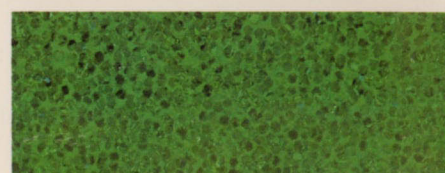

SPARKLE GREEN No. 2004



BUTCHER BLOCK CORTEX No. 2387



PSYCHEDELIC RED No. 2010

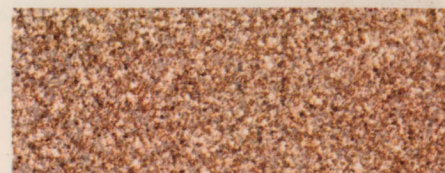

PINK CHAMPAGNE No. 2028



WALNUT CORTEX No. 2386



MAHOGANY CORTEX No. 2388



MAPLE CORTEX No. 2385

CHROME FINISH ON DRUM SHELLS ALSO AVAILABLE